

4D[®] TECH

peronda

El futuro cerámico no es qué. Es cómo.

4D TECH es el sistema de producción cerámica más innovador del mercado. Un nuevo estándar para la máxima calidad

With technology as our ace card.

4D TECH is the most innovative tile manufacturing system on the market, raising standards in a bid to achieve maximum quality.

MADE OF **peronda** 4D

El nuevo Peronda de siempre.

Nueva tecnología, mismos valores. 4DTECH aporta mayor precisión, versatilidad y eficiencia sin olvidar la calidad y la sostenibilidad.

A new yet familiar Peronda.

New technology but still the same values. 4DTECH ensures greater precision, versatility and efficiency, not to mention quality and sustainability.

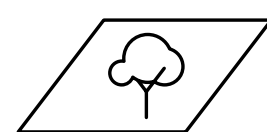

MAYOR NATURALIDAD
A more natural appearance

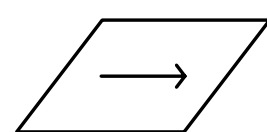

FABRICACIÓN EN PLANO CONTÍNUO
Continuous production process

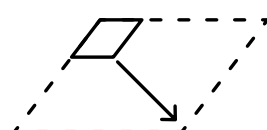

PIEZAS DE MAYOR TAMAÑO
Larger formats

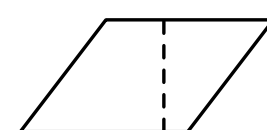

CORTE POR CUCHILLA EN CRUDO
Tiles cut while unfired

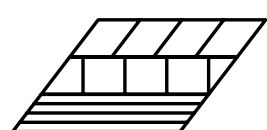

DECORACIÓN DIGITAL EN MASA
Through-body digital decoration



MEJOR DECORACIÓN DIGITAL SUPERFICIAL
Improved digital surface decor



VARIEDAD DE FORMATOS
More widely assorted formats

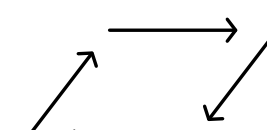

ECOLOGÍA
Eco-friendly

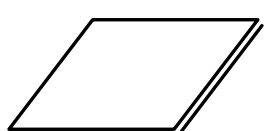

VARIEDAD DE ESPESORES
Varying thicknesses

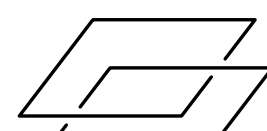

DURABILIDAD
Durability



MÁS ES MÁS

Nuevos formatos, no solo más grandes si no también más variedad de tamaños. Nuevos formatos hasta ahora impensables en cerámica.

DETALLES NUNCA VISTOS

La nueva tecnología 4DTECH confiere a los productos una precisión hasta ahora desconocida. Mayor definición en los detalles y unos efectos que siguen mejorando la realidad que nos inspira.

CREATIVIDAD SIN LIMITES

Las colecciones desarrolladas con las capacidades 4DTECH elevan el diseño a una nueva dimensión gracias a nuevas posibilidades matéricas y estéticas con las que enriquecer los productos.

APOSTAR POR LA INNOVACIÓN

Con la implantación de la nueva tecnología 4DTECH Peronda demuestra una vez más estar a la cabeza de la innovación en la industria cerámica garantizando así su crecimiento, siempre fiel a la máxima calidad.

EVEN MORE FORMATS

New formats – not just bigger ones but more widely assorted sizes. New sizes that were hitherto unconceivable in ceramic tiles.

SIMPLY AMAZING DETAIL

With new 4DTECH technology, a hitherto impossible degree of precision has been achieved. Higher-definition finer details and effects that continue to improve on our real sources of inspiration.

LIMITLESS CREATIVITY

Collections developed with 4TECH and its improved technology break new ground in design, thanks to its new aesthetic and material-related potential for enriching products.

COMMITTED TO INNOVATION

With the arrival of new 4DTECH technology, Peronda has yet again demonstrated that it is a trailblazer in the introduction of tile innovations, hence guaranteeing its growth through an ongoing search for maximum quality.

dimen^{4D}
sion

defini^{4D}
tion

desi^{4D}
gn

distin^{4D}
ction

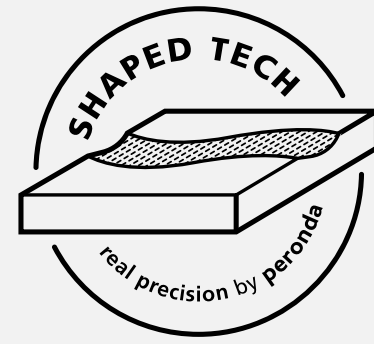

SHAPED TECH

Real precision by Peronda

Natural

Las texturas, los recovecos, las vetas que crea la naturaleza son caprichosas, y esa es la fuente de su belleza. No hay dos iguales, y en su singularidad radica su belleza.

La pasión por la búsqueda del detalle ha llevado a Peronda a desarrollar una tecnología capaz de reproducir la naturaleza en su máxima expresión, que es captando hasta el mínimo detalle.

Los relieves son creados con tecnología digital perfectamente coordinada con la impresión gráfica para generar las piezas más naturales vistas en cerámica.

Preciso

Donde ponemos el relieve ponemos la tinta. La precisión con la que imprimimos nuestras piezas es milimétrica, pues relieve y gráfica casan a la perfección para obtener un resultado técnicamente inmejorable.

Real

Nada de ilusiones ópticas, esto es real. Lo que ves y lo que tocas es lo mismo. La veta está donde está el relieve y viceversa. Lo que siempre quisimos en cerámica, ahora lo consigue Peronda.

Natural

The textures, sinuosity and veining found in nature all follow capricious rules, and it is this random nature that makes them so very lovely. Nothing is ever identical and this singularity is the secret to nature's beauty.

Peronda's passion for detail has led it to develop technology able to reproduce nature in its maximum of expressions, captured down to the tiniest of details.

Digital technology is used to create textures that coincide perfectly with the printed pattern, leading to some of the most natural looking designs ever to be seen on ceramic tiles.

Precise

Our printing inks reach each and every part of the printed texture. The tiles are printed with absolute precision, carefully marrying the design with the corresponding texture to unparalleled technical effect.

Real

There are no optical illusions. Everything is real. What you see and what you touch are one and the same thing. The printed veins coincide perfectly with the texture. Everything you have always longed for in ceramic tiles has now been achieved by Peronda.

PRESS TO VIEW

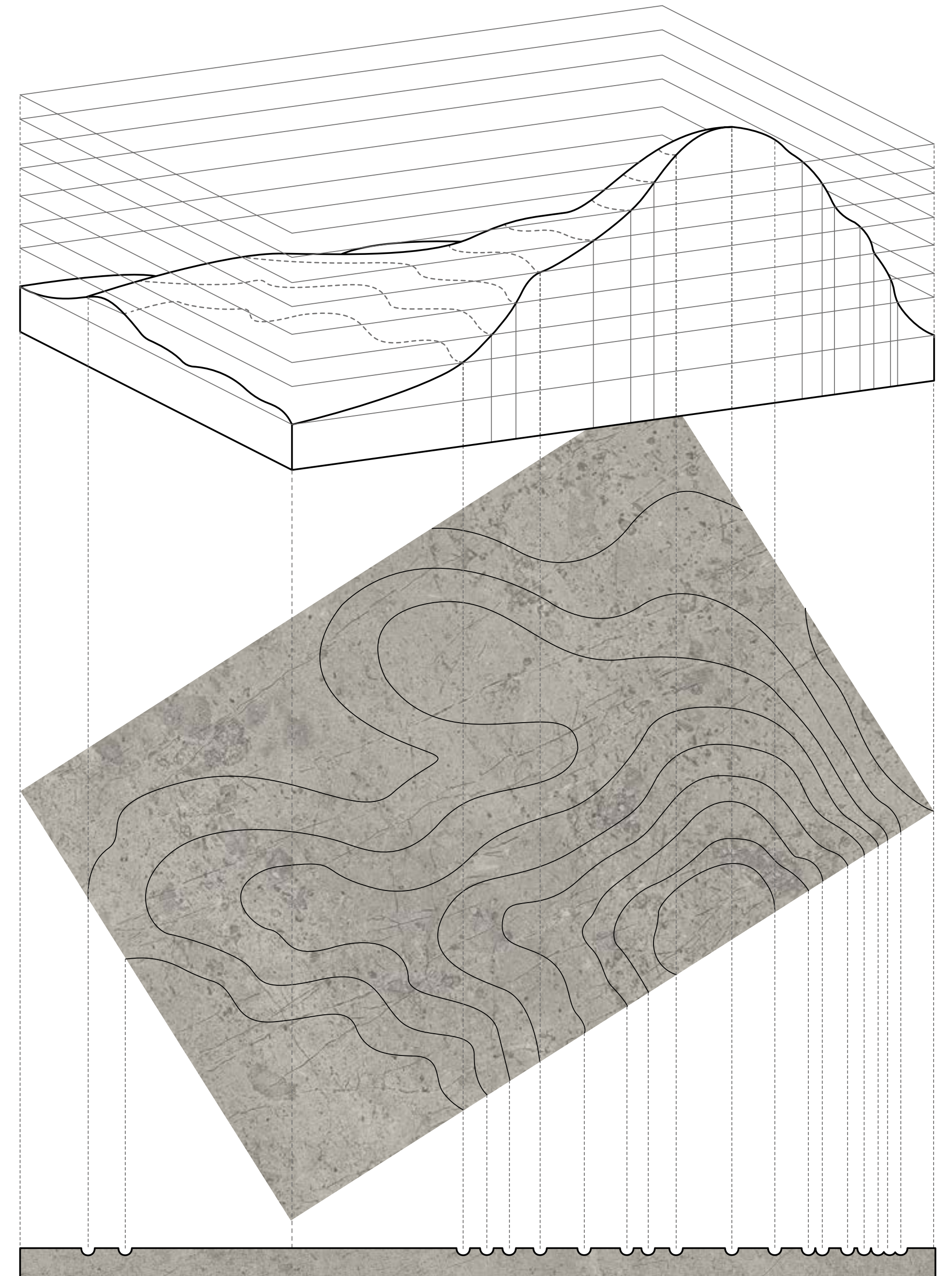

WHITE - SAND - GREY - ANTHRACITE

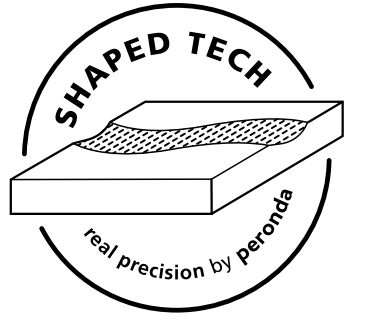

ALPINE 4D

beige



ALPINE Beige

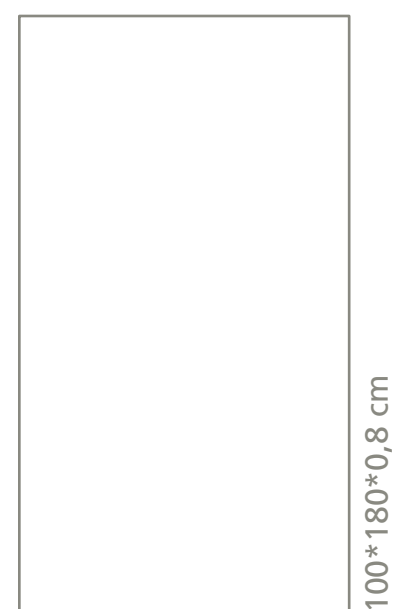

Shaped

100*180*0,8 cm

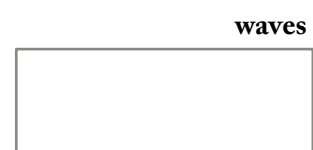

white body wall tile

32*90 cm

ALPINE 4D

beige



ALPINE Beige

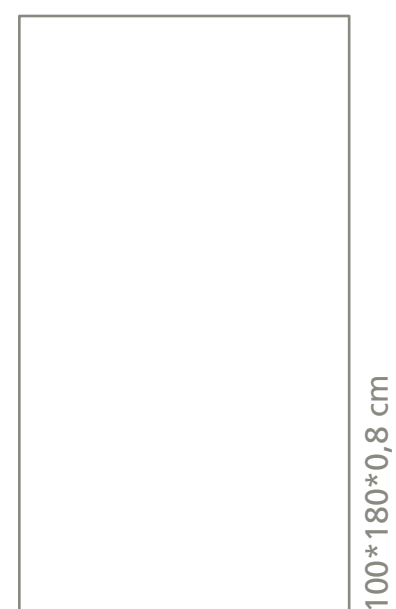

Shaped

100*180*0,8 cm

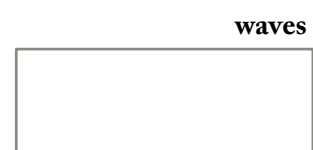

white body wall tile

waves

32*90 cm

ALPINE 4D

beige

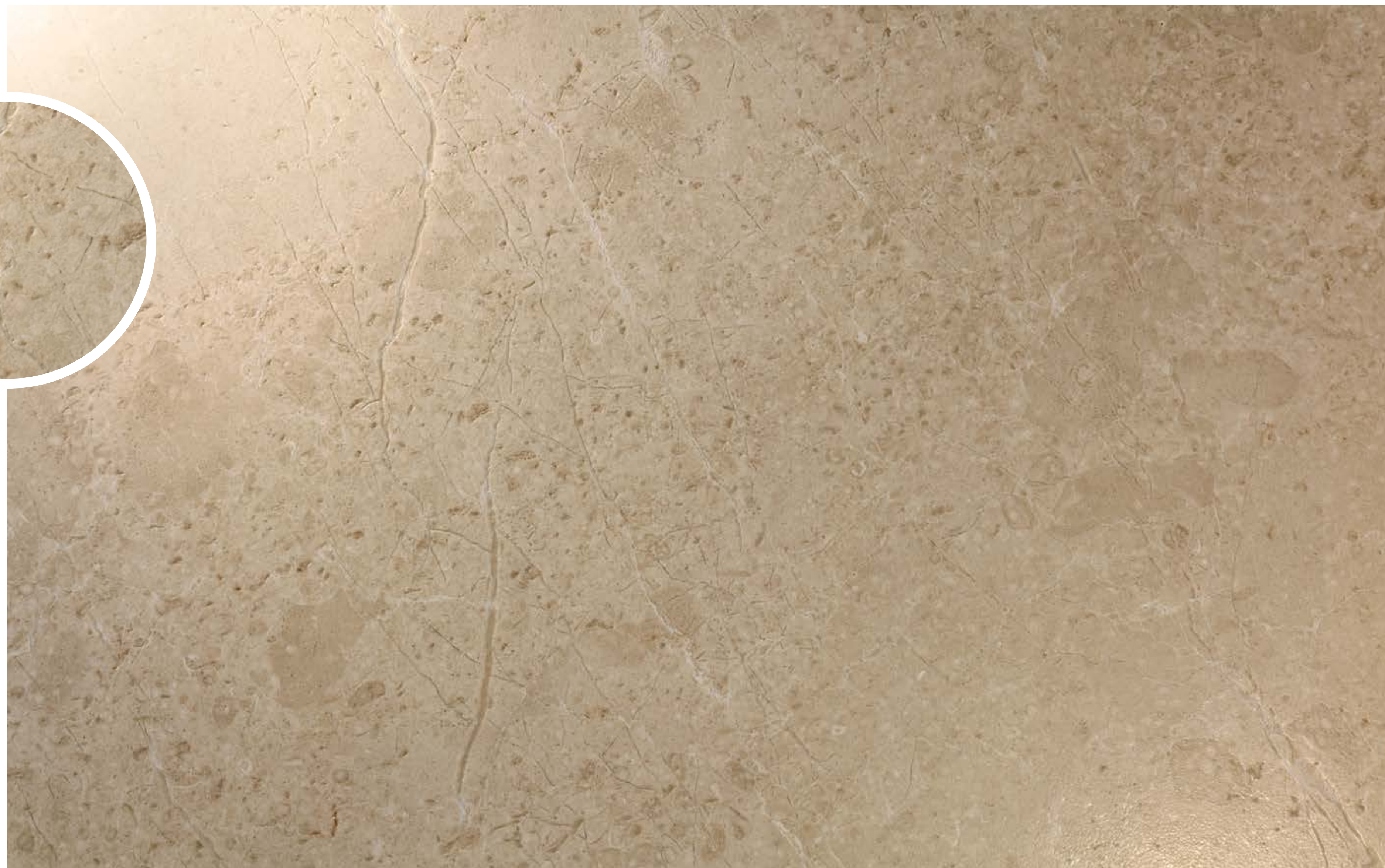

ALPINE Beige

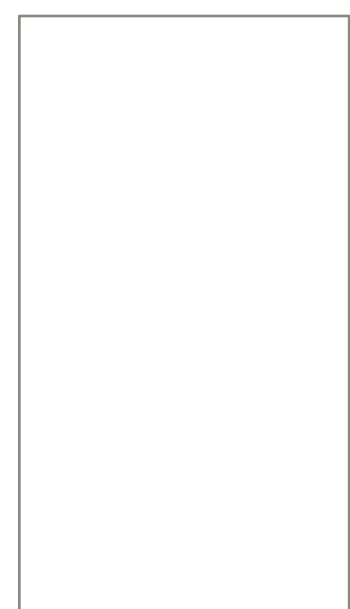

Shaped

100*180*0,8 cm



Shaped

100*100*0,8 cm

ALPINE 4D
white



ALPINE white



Shaped

100*180*0,8 cm

ALPINE 4D
beige



ALPINE Beigea



100*180*0,8 cm

Shaped

ALPINE 4D collection

ALPINE White



ALPINE Sand



ALPINE Grey



ALPINE Anthracite

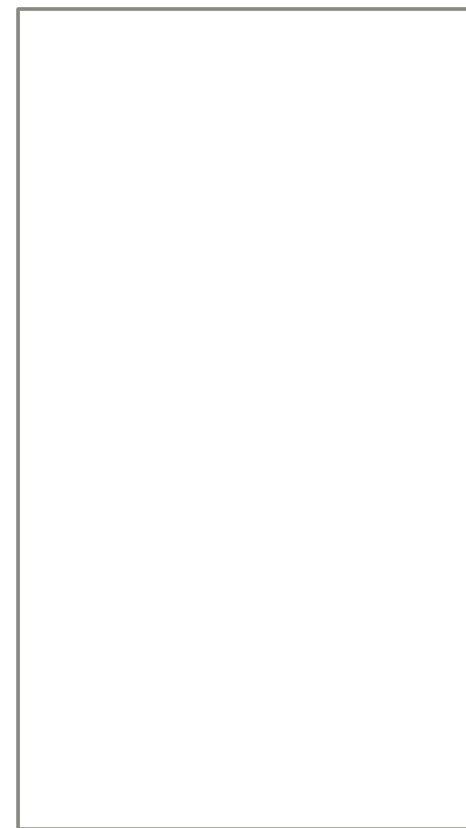

10 patterns

100 * 180 * 0,8 cm
39 * 71"

RECTIFIED	SHAPED	
	BN137	BN138
ANTHRACITE	28519	
BEIGE	28520	
GREY	28522	
WHITE		28521

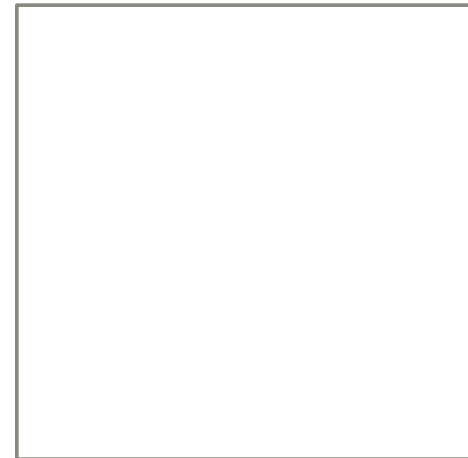

15 patterns

100 * 100 * 0,8 cm
39 * 39"

RECTIFIED	SHAPED	
	BN135	BN136
ANTHRACITE	28948	
BEIGE	28946	
GREY	28947	
WHITE		28945

ALPINE DECOR











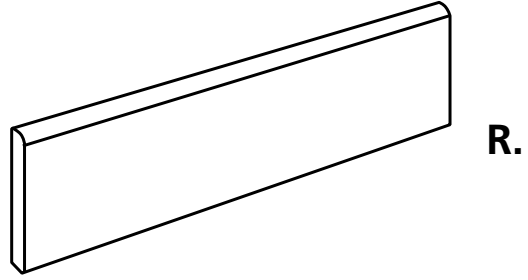
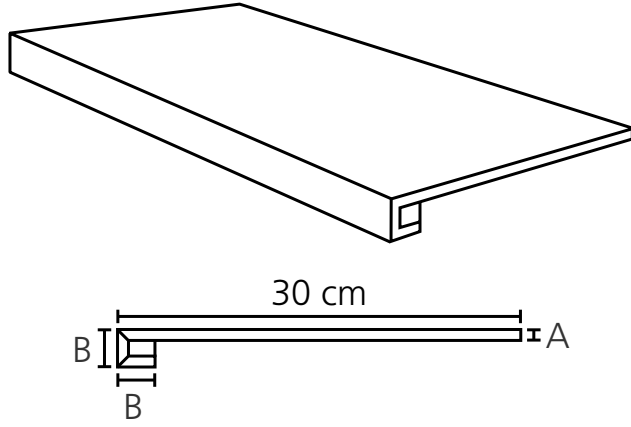
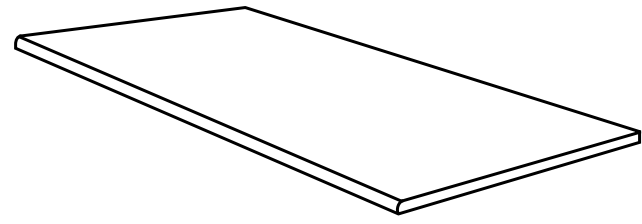
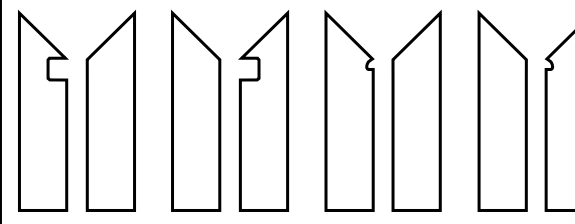

10 patterns

100 * 180 * 0,8 cm
39 * 71"

RECTIFIED	SHAPED	
	BN139	BN140
ANTHRACITE	29035	
BEIGE	29033	
GREY	29034	
WHITE		29036

ALPINE 4D collection

PIEZA COMPLEMENTARIA COMPLEMENTARY PIECE			
Rodapie - Skirting 	Peldaño técnico - Technical stair - thread 	Peldaño romo - Rounded stair - thread 	*S.K.I. *S.K.D. *Z.R.I. *Z.R.D. 
8*100 cm 3 * 39" P45	30*100 cm 12 * 39" P74 A= 0,8 cm B= 2,4 cm	30 * 100 cm 12 * 39" P85	8 * 30 cm 3*12" P53

CARACTERÍSTICAS TÉCNICAS TECHNICAL CHARACTERISTICS								
joint 	frost proof 	versatile 	mat 	full body 	diferent shades 	shade variation 	various graphics 	thickness 

CARACTERÍSTICAS TÉCNICAS ANTIDESLIZAMIENTO ANTI-SLIP CHARACTERISTICS		
Ensayo Essay	Características Features	Resultado Result
UNE-ENV 12633	Antideslizamiento (Test del péndulo) Slip resistance (Pendulum test)	Class 1
ANSI A.1371	Coeficiente de Fricción Dinámico Dynamic Coefficient of Friction (DCOF)	>0,42
ISO 10545-6	Resistencia a la abrasion profunda/ Resistance to Deep Abrasion	< 175 mm ³

EMBALAJE PACKING								(Los pesos aquí reflejados pueden sufrir ligeras variaciones en función del lote de producción. Weights shown here may slightly vary depending on the production lot.)	
Formato Sizes	Cajas Boxes			Pallet				Cont./20' 21500 kg.	Cont./20' 24000 kg.
cm	Piezas	m ² / sq.m	kg	Cajas	m ² / sq.m	kg	Tamaño cm aprox.	m ² / sq.m	m ² / sq.m
180 * 100 * 0,8	2	3,6	70,25	20	72	1455	181 * 112 * 64	1063,92	1187,63
100 * 100 * 0,8	2	2	37	32	64	1226	112 * 112 * 64	1122,35	1252,85
inch	units	ft ²	lb	Boxes	ft ²	lb	Sizes Inch approx.	ft ²	ft ²
70 7/8 * 39 3/8 * 5/16	2	38,75	154,87	20	775	3207,73	71 1/4 * 44 1/16 * 25 3/16	11451,94	12783,54
39 3/8 * 39 3/8 * 5/16	2	21,53	81,59	32	688,9	2703,33	44 1/16 * 44 1/16 * 25 3/16	12080,97	13485,73

WHITE - SAND - GREY - ANTHRACITE



MYSTIC 4D
white



MYSTIC White

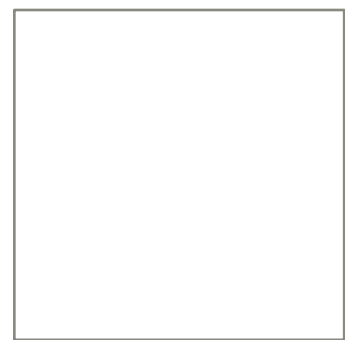

100*100*0,8 cm

Bush hammered

MYSTIC 4D
sand_anthracite



MYSTIC Sand_Anthracite



100*100*0,8 cm

Bush hammered



50*100*0,8 cm

Natural

MYSTIC 4D
sand_anthracite



MYSTIC Sand_Anthracite

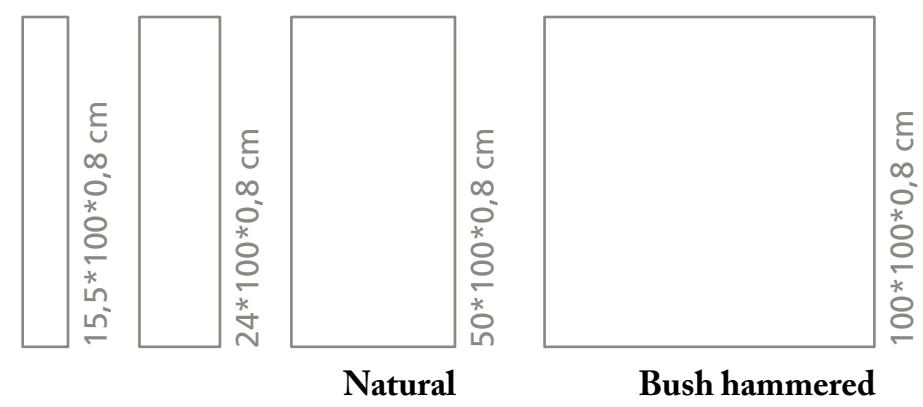

MYSTIC 4D
grey

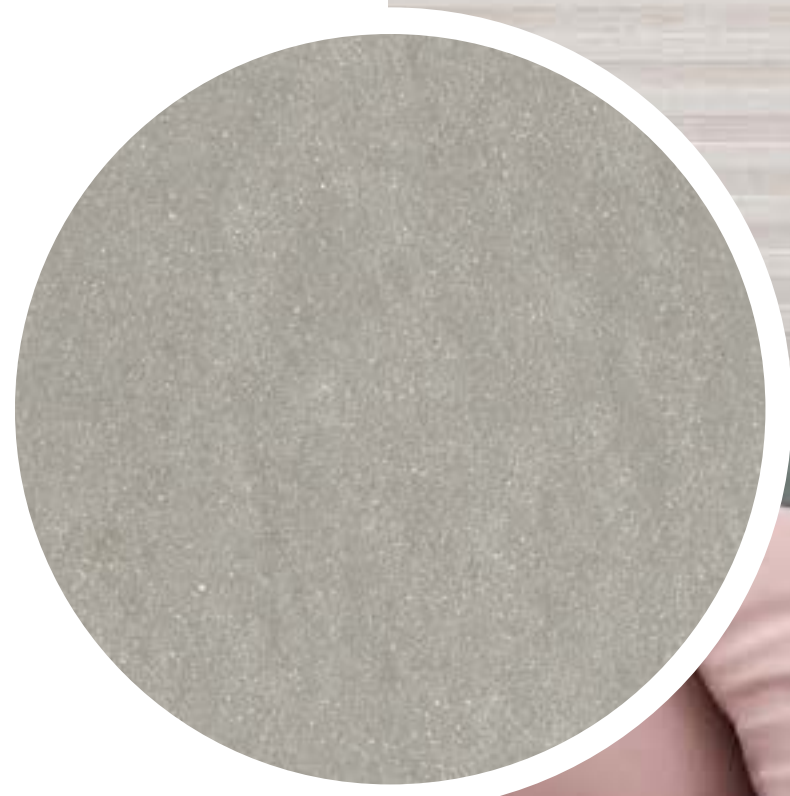

MYSTIC Grey



100*100*0,8 cm

Normal

MYSTIC 4D collection

MYSTIC White



MYSTIC Sand



MYSTIC Grey



MYSTIC Anthracite

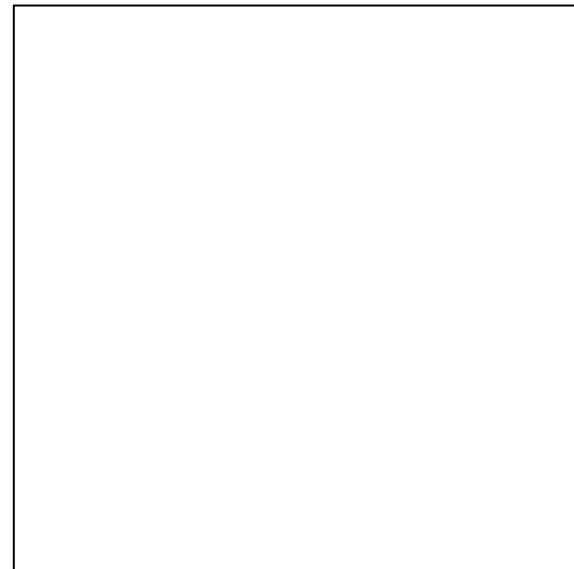

12 patterns

100 * 100 * 0,8 cm
39 * 39"

RECTIFIED	NATURAL BN94	BUSH HAMMERED BN94	ANTISLIP BUSH HAMMERED BN99
WHITE	25394	25391	25390
SAND	24340	24344	24355
GREY	24342	24346	24354
ANTHRACITE	24339	24345	24353

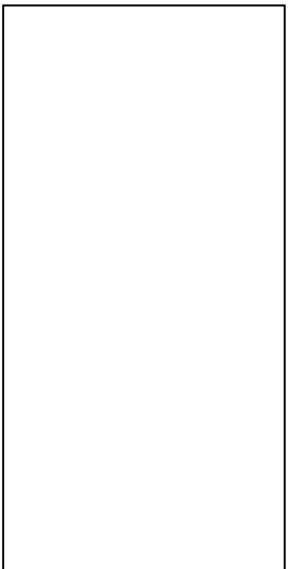

24 patterns

50 * 100 * 0,8 cm
20 * 39"

RECTIFIED	NATURAL BN96
WHITE	25397
SAND	24359
GREY	24358
ANTHRACITE	24357



48 patterns

24 * 100 * 0,8 cm
10 * 39"

RECTIFIED	NATURAL BN109	BUSH HAMMERED BN109
WHITE	25396	25393
SAND	24592	24645
GREY	24594	24642
ANTHRACITE	24595	24640



72 patterns

15,5 * 100 * 0,8 cm
6 * 39"

RECTIFIED	NATURAL BN108	BUSH HAMMERED BN108
WHITE	25395	25392
SAND	24597	24654
GREY	24598	24650
ANTHRACITE	24596	24648

D. MYSTIC MOSAIC

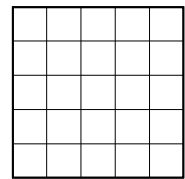

25 * 25 cm | 10 * 10"

NO RECTIFIED	NATURAL P39
WHITE	25428
SAND	24479
GREY	24477
ANTHRACITE	24476

D. MYSTIC BRICK



29,8 * 29,2 cm | 12 * 12"





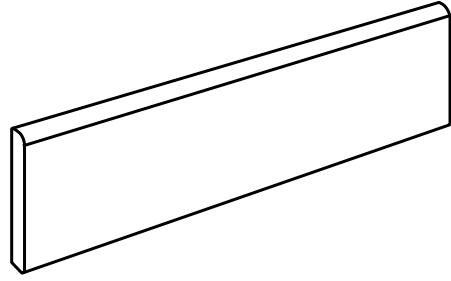
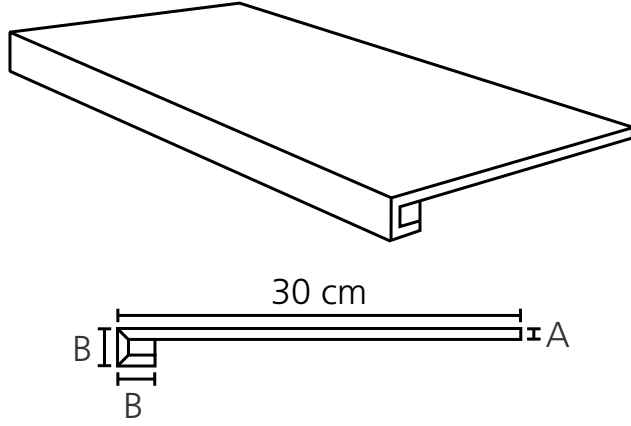
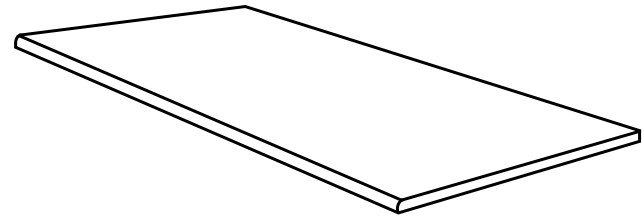
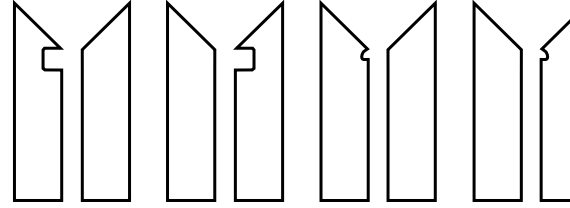

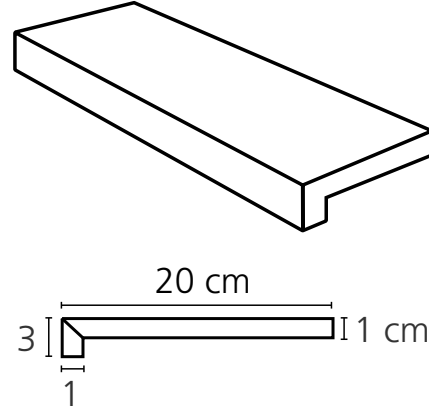
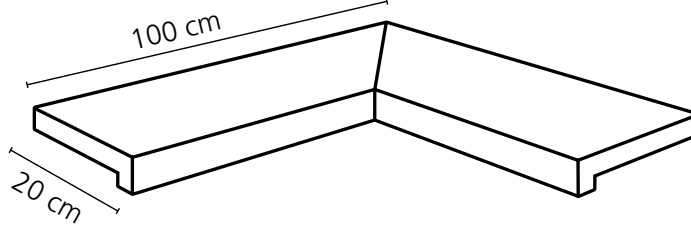
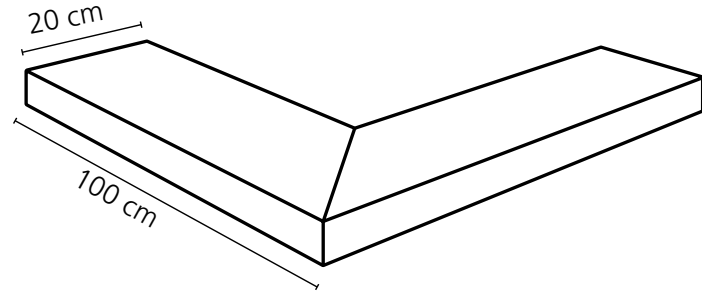
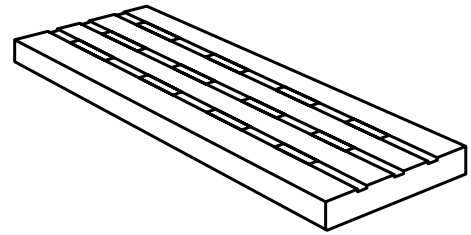
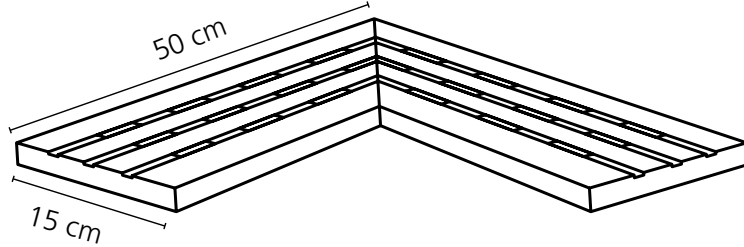
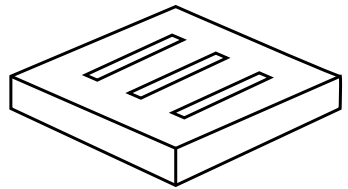

NO RECTIFIED	NATURAL P50
WHITE	25427
SAND	24461
GREY	24459
ANTHRACITE	24458

MYSTIC 4D
collection

PIEZA COMPLEMENTARIA COMPLEMENTARY PIECE			
Rodapie - Skirting  R.	Peldaño técnico - Technical stair - thread  P.	Peldaño romo - Rounded stair - thread  R.P	*S.K.I. *S.K.D. *Z.R.I. *Z.R.D. 
8*100 cm 3 * 39" P45	30*100 cm 12 * 39" P74 A= 0,8 cm B= 2,4 cm	30 * 100 cm 12 * 39" P85	8 * 30 cm 3*12" P53

PIEZA ESPECIAL PISCINA SPECIAL PIECE POOL			*Pedido mínimo 10 unidades Minimum order 10 items
Peldaño Vierteagua Pool Coping  P.V.	Peldaño vierteagua angulo Pool Coping internal corner  ANG.P.V.	Peldaño vierteagua esquina Pool Coping external corner  E.P.V.	
20 * 100 cm 8 * 39" P82	100 * 100 cm 39 * 39" P80 (PACK 2 units)	100 * 100 cm 39 * 39" P80 (PACK 2 units)	
Rejilla Drainage grate  REJ.	Angulo rejilla Angle corner drainage grate  ANG.REJ.	Taco rejilla Square corner drainage grate  T.REJ.	
15*50*1,6 cm 6 * 20" P87	50 * 50 * 1,6 cm 20 * 20" P74 (PACK 2 units)	15 * 15 * 2,2 cm 6 * 6" P66	

MYSTIC 4D collection

CARACTERÍSTICAS TÉCNICAS TECHNICAL CHARACTERISTICS								
joint 	frost proof 	versatile 	matt 	full body 	diferent shades 	shade variation 	various graphics 	thickness 

CARACTERÍSTICAS TÉCNICAS ANTIDESLIZAMIENTO ANTI-SLIP CHARACTERISTICS				
Ensayo Essay	Características Features	Resultado Result		
		NATURAL	BUSH HAMMERED	ANTISLIP BUSH HAMMERED
DIN 51130	Ángulo crítico (Pies calzados) Critical angle (footwear)	R9	R10	R12
DIN 51097	Ángulo crítico (Pies descalzos) Critical angle (Wet loaded barefoot)	A	A+B	A+B+C
BS 7976-2	Antideslizamiento (Test del péndulo) Slip resistance (Pendulum test)	-	+36 Wet	+36 Wet
UNE-ENV 12633	Antideslizamiento (Test del péndulo) Slip resistance (Pendulum test)	Class 1	Class 2	Class 3
ANSI A.1371	Coeficiente de Fricción Dinámico Dynamic Coefficient of Friction (DCOF)	>0,42	>0,42	>0,42
ISO 10545-6	Resistencia a la abrasion profunda/ Resistance to Deep Abrasion	< 175 mm ³	< 175 mm ³	< 175 mm ³

EMBALAJE PACKING								(Los pesos aquí reflejados pueden sufrir ligeras variaciones en función del lote de producción. Weights shown here may slightly vary depending on the production lot.)	
Formato Sizes	Cajas Boxes			Pallet				Cont./20' 21500 kg.	Cont./20' 24000 kg.
cm	Piezas	m ² / sq.m	kg	Cajas	m ² / sq.m	kg	Tamaño cm aprox.	m ² / sq.m	m ² / sq.m
100 * 100 * 0,8	2	2	37	32	64	1226	112 * 112 * 64	1122,35	1252,85
50 * 100 * 0,8	3	1,5	28,2	24	36	719	120 * 80 * 66	1076,5	1201,67
24 * 100 * 0,8	4	0,96	17,8	40	38,4	736	120 * 80 * 63	1121,74	1252,17
15,5 * 100 * 0,8	8	1,24	22,8	32	39,68	771	112 * 112 * 56	1106,5	1235,18
inch	units	ft ²	lb	Boxes	ft ²	lb	Sizes Inch approx.	ft ²	ft ²
39 3/8 * 39 3/8 * 5/16	2	21,53	81,40	32	688,89	2702,86	44 1/16 * 44 1/16 * 25 3/16	12080,97	13485,73
19 11/16 * 39 3/8 * 5/16	3	16,1	62,2	24	387,5	1547,65	47 1/4 * 31 1/2 * 26	11587,39	12934,76
9 7/16 * 39 3/8 * 5/16	4	10,33	39,25	40	413,34	1622,88	47 1/4 * 31 1/2 * 24 1/2	12074,4	13478,4
3 15/16 * 39 3/8 * 5/16	8	13,35	50,27	32	427,34	1700	44 1/16 * 44 1/16 * 25 3/16	11910,48	13295,42

WHITE - SAND - SILVER - GREY - ANTHRACITE

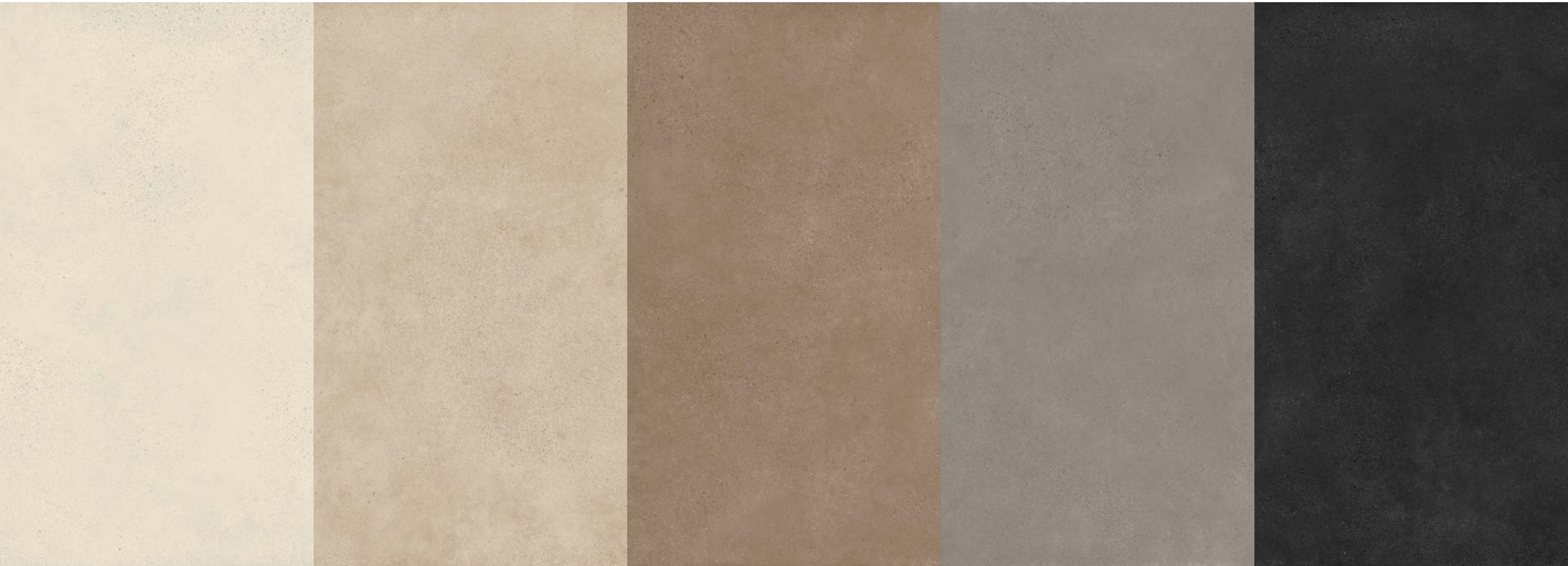

ALLEY 4D
white_grey



ALLEY White_Grey



100*100*0,8 cm

Natural
Bush hammered



50*100*0,8 cm

Natural

ALLEY 4D

bone



ALLEY Bone



24*100*0,8 cm



50*100*0,8 cm



100*100*0,8 cm

Natural

Bush hammered

ALLEY 4D
anthracite



ALLEY Anthracite



100*100*0,8 cm

Natural

ALLEY 4D
mud



ALLEY Mud



100*100*0,8 cm

Bush Hammered

ALLEY 4D collection

ALLEY White

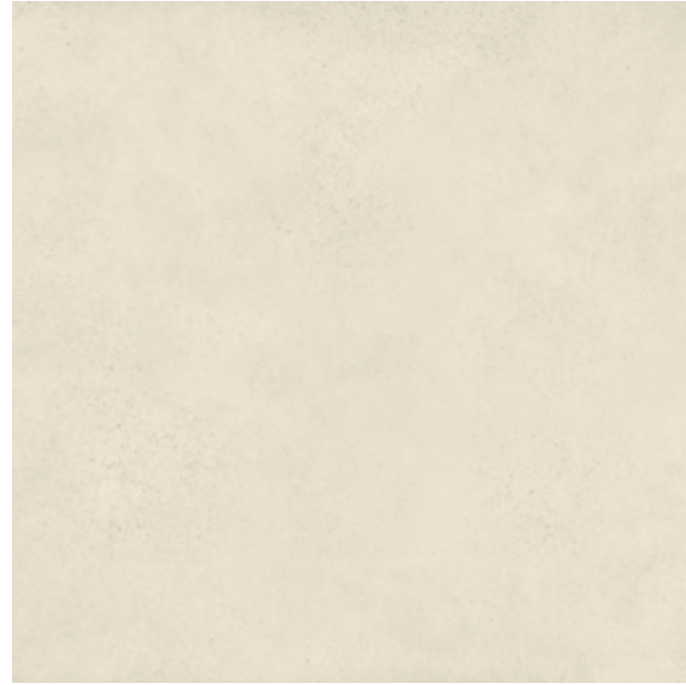

ALLEY Bone



ALLEY Grey



ALLEY Mud



ALLEY Anthracite

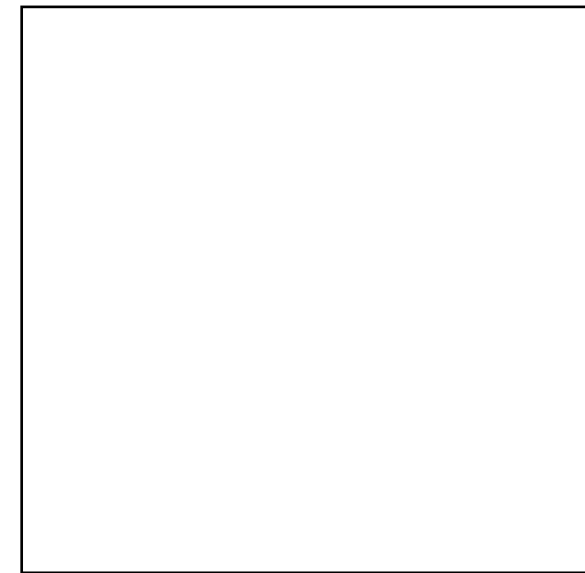

9 patterns

100 * 100 * 0,8 cm | 39 * 39"

RECTIFIED	NATURAL		ANTISLIP BUSH HAMMERED	
	BN94	BN110	BN99	BN112
WHITE	-	23396	-	23401
BONE	23398	-	23403	-
GREY	23397	-	23402	-
MUD	23399	-	23404	-
ANTHRACITE	23400	-	23405	-

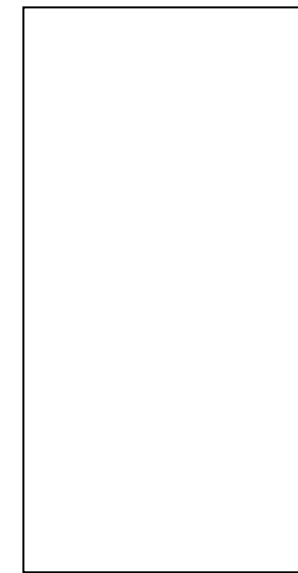

18 patterns

50 * 100 * 0,8 cm | 20 * 39"

RECTIFIED	NATURAL		ANTISLIP BUSH HAMMERED	
	BN96	BN111	BN103	BN113
WHITE	-	23406	-	23411
BONE	23408	-	23413	-
GREY	23407	-	23412	-
MUD	23409	-	23414	-
ANTHRACITE	23410	-	23415	-

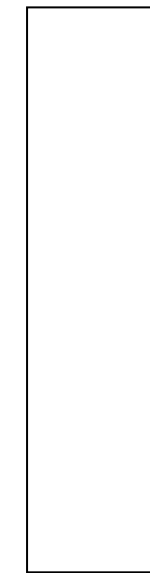

36 patterns

24 * 100 * 0,8 cm | 10 * 39"

RECTIFIED	NATURAL BN109
WHITE	23800
BONE	23801
GREY	23802
MUD	23803
ANTHRACITE	23828

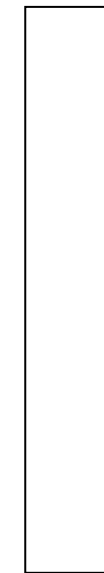

54 patterns

15,5 * 100 * 0,8 cm | 6 * 39"

RECTIFIED	NATURAL BN108
WHITE	23805
BONE	23806
GREY	23807
MUD	23808
ANTHRACITE	23809

D. ALLEY MOSAIC

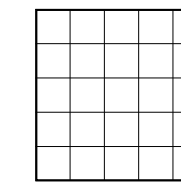

25 * 25 cm | 10 * 10"

NO RECTIFIED	NATURAL P39	ANTISLIP BUSH HAMMERED P39
WHITE	23485	23491
BONE	23482	23487
GREY	23483	23489
MUD	23484	23490
ANTHRACITE	23481	23488

D. ALLEY BRICK

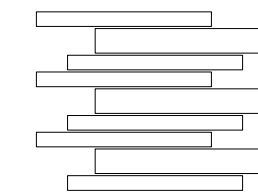

29,8 * 29,2 cm | 12 * 12"







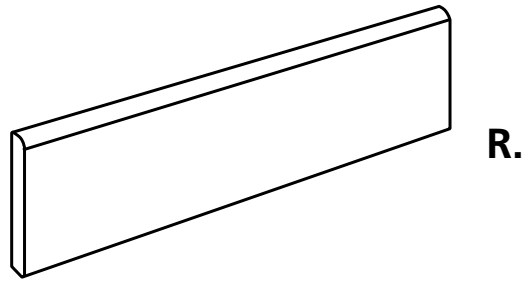
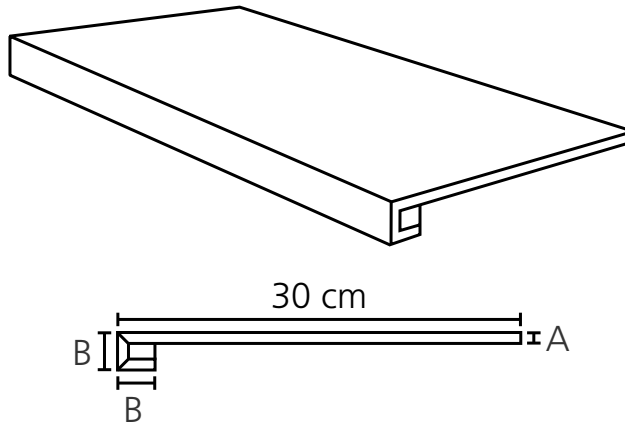
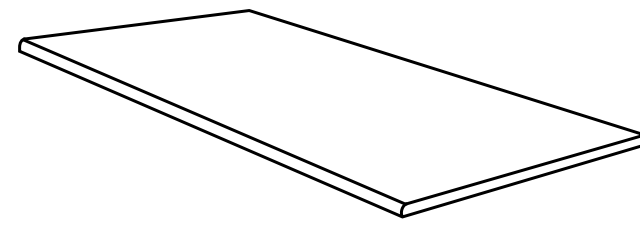
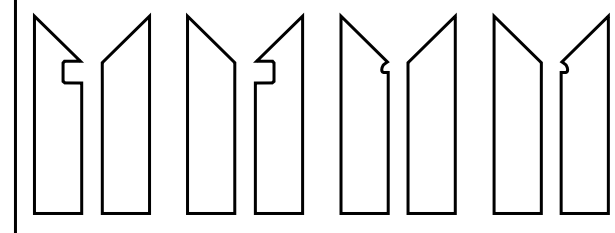

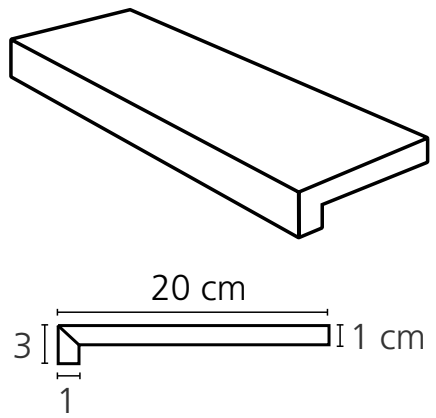
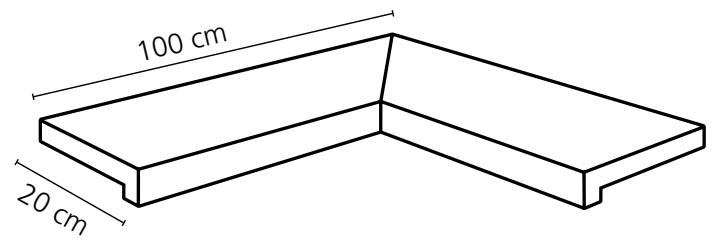
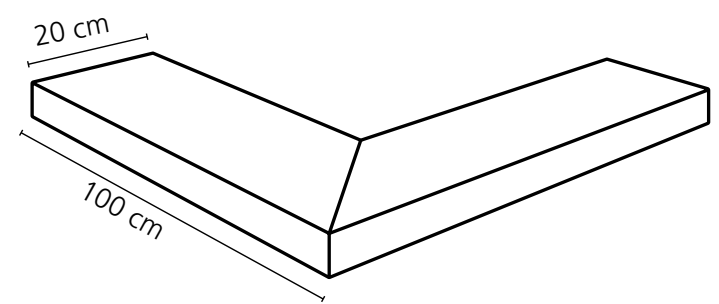
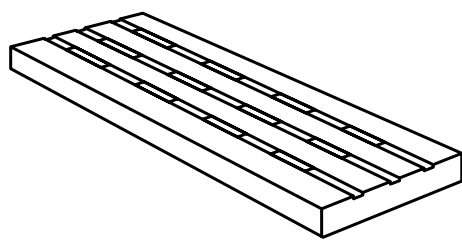
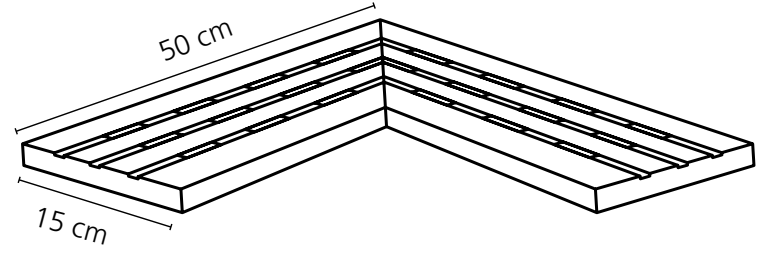
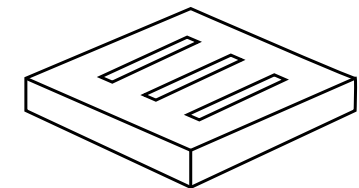
NO RECTIFIED	NATURAL P50
WHITE	23497
BONE	23494
GREY	23495
MUD	23496
ANTHRACITE	23493

22303 ALUMINIO/100/MAT _ 100 * 0,5 cm | 39 * 0,2" _ P42

26153 L. GOLDEN/MAT/100 _ 100 * 0,5 cm | 39 * 0,2" _ P42

PIEZA COMPLEMENTARIA COMPLEMENTARY PIECE			
<p>Rodapie - Skirting</p>  <p>R.</p>	<p>Peldaño técnico - Technical stair - thread</p>  <p>P.</p>	<p>Peldaño romo - Rounded stair - thread</p>  <p>R.P.</p>	<p>*S.K.I. *S.K.D. *Z.R.I. *Z.R.D.</p> 
<p>8*100 cm 3 * 39" P45</p>	<p>30*100 cm 12 * 39" P74 A= 0,8 cm B= 2,4 cm</p>	<p>30 * 100 cm 12 * 39" P85</p>	<p>8 * 30 cm 3*12" P53</p>

PIEZA ESPECIAL PISCINA SPECIAL PIECE POOL			*Pedido mínimo 10 unidades Minimum order 10 items
<p>Peldaño Vierteagua Pool Coping</p>  <p>P.V.</p>	<p>Peldaño vierteagua angulo Pool Coping internal corner</p>  <p>ANG.P.V.</p>	<p>Peldaño vierteagua esquina Pool Coping external corner</p>  <p>E.P.V.</p>	
<p>20 * 100 cm 8 * 39" P82</p>	<p>100 * 100 cm 39 * 39" P80 (PACK 2 units)</p>	<p>100 * 100 cm 39 * 39" P80 (PACK 2 units)</p>	
<p>Rejilla Drainage grate</p>  <p>REJ.</p>	<p>Angulo rejilla Angle corner drainage grate</p>  <p>ANG.REJ.</p>	<p>Taco rejilla Square corner drainage grate</p>  <p>T.REJ.</p>	
<p>15*50*1,6 cm 6 * 20" P87</p>	<p>50 * 50 * 1,6 cm 20 * 20" P74 (PACK 2 units)</p>	<p>15 * 15 * 2,2 cm 6 * 6" P66</p>	

CARACTERÍSTICAS TÉCNICAS TECHNICAL CHARACTERISTICS								
joint 	frost proof 	versatile 	matt 	full body 	diferent shades 	shade variation 	various graphics 	thickness 

CARACTERÍSTICAS TÉCNICAS ANTIDESLIZAMIENTO ANTI-SLIP CHARACTERISTICS			
Ensayo Essay	Características Features	Resultado Result	
		NATURAL	ANTISLIP BUSH HAMMERED
DIN 51130	Ángulo crítico (Pies calzados) Critical angle (footwear)	R9	R12
DIN 51097	Ángulo crítico (Pies descalzos) Critical angle (Wet loaded barefoot)	A	A+B+C
BS 7976-2	Antideslizamiento (Test del péndulo) Slip resistance (Pendulum test)	-	+36 Wet
UNE-ENV 12633	Antideslizamiento (Test del péndulo) Slip resistance (Pendulum test)	Class 1	Class 3
ANSI A.1371	Coeficiente de Fricción Dinámico Dynamic Coefficient of Friction (DCOF)	>0,42	>0,42
ISO 10545-6	Resistencia a la abrasion profunda/ Resistance to Deep Abrasion	< 175 mm ³	< 175 mm ³

EMBALAJE PACKING								(Los pesos aquí reflejados pueden sufrir ligeras variaciones en función del lote de producción. Weights shown here may slightly vary depending on the production lot.)	
Formato Sizes	Cajas Boxes			Pallet				Cont./20' 21500 kg.	Cont./20' 24000 kg.
cm	Piezas	m ² / sq.m	kg	Cajas	m ² / sq.m	kg	Tamaño cm aprox.	m ² / sq.m	m ² / sq.m
100 * 100 * 0,8	2	2	37	32	64	1226	112 * 112 * 64	1122,35	1252,85
50 * 100 * 0,8	3	1,5	28,2	24	36	719	120 * 80 * 66	1076,5	1201,67
24 * 100 * 0,8	4	0,96	17,8	40	38,4	736	120 * 80 * 63	1121,74	1252,17
15,5 * 100 * 0,8	8	1,24	22,8	32	39,68	771	112 * 112 * 56	1106,5	1235,18
inch	units	ft ²	lb	Boxes	ft ²	lb	Sizes Inch approx.	ft ²	ft ²
39 ³ / ₈ * 39 ³ / ₈ * 5 ¹ / ₁₆	2	21,53	81,40	32	688,89	2702,86	44 ¹ / ₁₆ * 44 ¹ / ₁₆ * 25 ³ / ₁₆	12080,97	13485,73
19 ¹¹ / ₁₆ * 39 ³ / ₈ * 5 ¹ / ₁₆	3	16,1	62,2	24	387,5	1547,65	47 ¹ / ₄ * 31 ¹ / ₂ * 26	11587,39	12934,76
9 ⁷ / ₁₆ * 39 ³ / ₈ * 5 ¹ / ₁₆	4	10,33	39,25	40	413,34	1622,88	47 ¹ / ₄ * 31 ¹ / ₂ * 24 ¹ / ₂	12074,4	13478,4
3 ¹⁵ / ₁₆ * 39 ³ / ₈ * 5 ¹ / ₁₆	8	13,35	50,27	32	427,34	1700	44 ¹ / ₁₆ * 44 ¹ / ₁₆ * 25 ³ / ₁₆	11910,48	13295,42

peronda

Debido a los procesos de impresión, los colores que aparecen en este catálogo deben considerarse aproximados, y no exactos. **All colours and hues appearing in this catalogue should be considered approximate, only in view of the printing processes involved.**

Los derechos de todos los contenidos (textos, fotografías, dibujos, diseños etc) del presente catálogo son propiedad de PERONDA GROUP, S.A (o en su defecto, cuentan con los correspondientes permisos y autorizaciones de sus titulares). No está permitida la reproducción total o parcial de esta publicación, ni su tratamiento informático, ni la transmisión de ninguna forma o por cualquier medio, ya sea electrónico, mecánico, por fotocopia, por registro u otros medios, sin el permiso previo y por escrito de los titulares del copyright. **The rights of all contents (texts, photographs, drawings, designs, etc.) of this catalogue remain the property of PERONDA GROUP, S.A (or, failing that, they have the corresponding permissions and authorizations of the owners). No part of this publication may be reproduced, stored in a retrieval system, or transmitted in any form or by any means, electronic, mechanical, photocopying, recording or otherwise, without the prior written permission of the copyright holders.**

© PERONDA GROUP 2020
Av. Manuel Escobedo, 26.
12200 Onda (Castellón) España

4D[®] TECH

peronda