



Poligono Industrial Vilaseca,1

Tel. 0034 938 593 511

Fax 0034 938 593 300

08571 Sant Vicenç de Torelló

(Barcelona) SPAIN

E-mail: info@ffbofill.com

www.ffbofill.com



CERTIFICADO

**La Entidad Certificadora TÜV CERT
de TÜV Anlagentechnik GmbH**
Unternehmensgruppe TÜV Rheinland/Berlin-Brandenburg

certifica, conforme al procedimiento
TÜV CERT, que la empresa

F.F. BOFILL, S.A.
Pol. Ind. Vilaseca I, s/n
E-08571 Sant Vicenç de Torelló
Barcelona

ha implantado y aplica un Sistema de Calidad para el área

**Fabricación de conductos metálicos para salida
de humos de calderas y chimeneas**

Mediante auditoria realizada, con
nº de informe **028101**

se verificó el cumplimiento de las exigencias recogidas en la norma

DIN EN ISO 9001:2000

Este certificado es válido hasta **Abril 2008**
Nº de registro del certificado **01 100 028101**



TÜV Rheinland/
Berlin-Brandenburg

Entidad Certificadora
de TÜV Anlagentechnik

Colonia, 2002-04-08

**Empresa con un sistema de calidad
certificado según ISO 9001:2000.**

**Company with an established quality
system according to ISO 9001:2000.**

AENOR Asociación Española de
Normalización y Certificación

CERTIFICADO DE CONFORMIDAD CE
EC Certificate of conformity

0099/CPD/A71/001

2005-05-21
Pg. 1/2

En virtud del Real Decreto 1630/1992, de 29 de diciembre, modificado por el Real Decreto 1326/1990, de 28 de julio, por el que se dictan disposiciones para la aplicación de la directiva 89/106/CEE del Consejo de las Comunidades Europeas, de 21 de diciembre de 1988, relativa a la aproximación de las disposiciones legales, reglamentarias y administrativas de los Estados Miembros sobre los productos de construcción, se ha verificado que el

In application of the Royal Decree 1630/1992 of 29 December 1992, as amended by Royal Decree 1326/1990 of 28 July 1990, relative to the application of the directive 89/106/EEC of the Council of European Communities of 21 December 1988 on the approximation of laws, regulations and administrative provisions of the Member States relating to the construction products (Construction Products Directive), it has been stated that the

Producto: **CHIMENEAS METÁLICAS MODULARES**
Product: **METAL SYSTEM CHIMNEYS**

Referencia: **ver anexo**
Reference: **see annex**

Norma: **UNE-EN 1856-1:2004 (EN 1856-1:2003)**
Standard:

Suministrado por: **F.F. BOFILL, S.A.**
Supplied by: **PI VILASECA, 1 - 08571 SANT VICENÇ DE TORELLÓ (Barcelona - ESPAÑA)**

Fabricado en: **PI VILASECA, 1**
Manufactured in: **08571 SANT VICENÇ DE TORELLÓ (Barcelona - ESPAÑA)**

se somete por el fabricante a un control de producción en fábrica y al ensayo posterior de las muestras tomadas en la fábrica de acuerdo con un plan de ensayo establecido y que el organismo notificado AENOR ha llevado a cabo la inspección inicial de la fábrica y del control de producción en fábrica y que realiza el seguimiento periódico, la evaluación y la aprobación del control de producción en fábrica. Este certificado indica que se ha aplicado todas las disposiciones relativas a la realización de la conformidad descritas en el Anexo ZA, de la norma mencionada arriba y que el producto cumple todas las requisitos mínimos. Este documento acredita al fabricante para fijar el marcado CE. Este certificado es válido salvo anulación o retirada por AENOR.

is submitted by the manufacturer to a factory production control and to the further testing of samples taken at the factory in accordance with a prescribed test plan and that the notified body AENOR has performed the initial inspection of the factory and of the factory production control and performs the periodic surveillance, assessment and approval of the factory production control. This certificate attests that all provisions concerning the attestation of conformity described in Annex ZA of the above mentioned standard were applied and that the product fulfils all the minimum prescribed requirements. This document allows the manufacturer to affix the CE marking. This Certificate remains valid unless cancelled or withdrawn by AENOR.

Fecha de concesión: **2005-05-20**
Date of first issue:

Fecha de emisión: **2005-05-21**
Date of issue:

AENOR Asociación Española de
Normalización y Certificación

Rafael NAZ PAJARES
El Director General/General Manager

**Producto certificado según norma
UNE EN 1856-1:2004**

**Pipes officially homologated with
UNE EN 1856-1:2004**

Nº de certificado/Certificate number:
0099/CPD/A71/001, 0099/CPD/A71/002, 0099/CPD/A71/004



Polígono Industrial Vilaseca,1

Tel. 0034 938 593 511

Fax 0034 938 593 300

08571 Sant Vicenç de Torelló

(Barcelona) SPAIN

E-mail: info@ffbofill.com

www.ffbofill.com

EXPORT

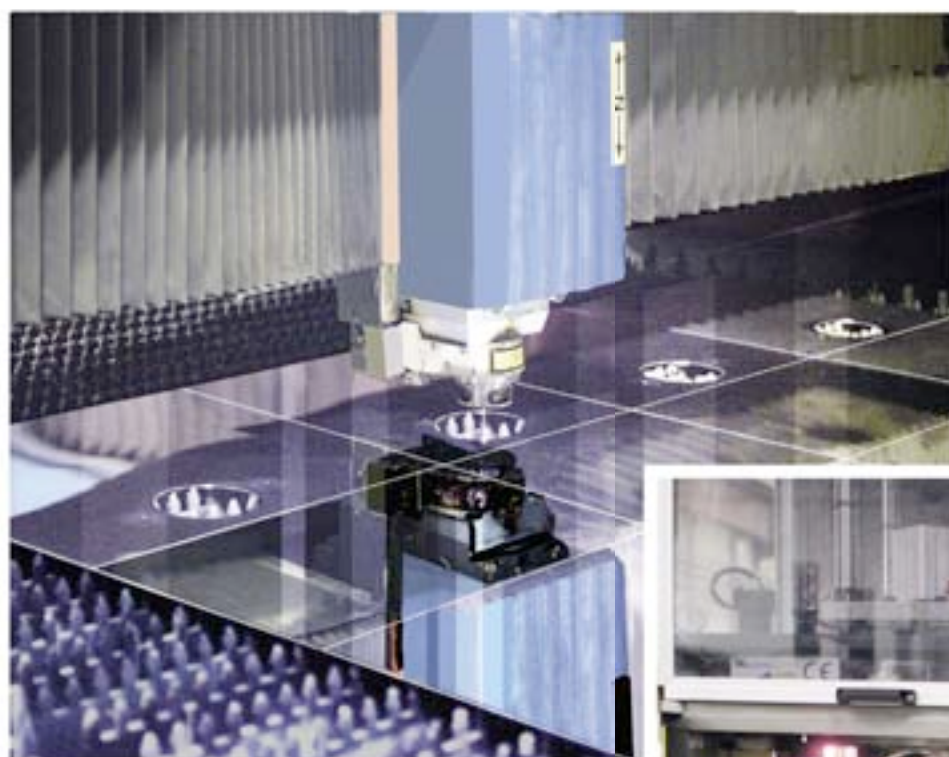



Indice

Pag.

Instucciones montaje chimenea	6-7
Gráfica para determinar el diámetro	8
Formulario dimensionamiento	9
Cálculo desviaciones en grados	10-13
Ficha técnica diámetros 80-300	14
Chimenea modular aislada 80-300	15-24
Chimenea modular inox-cobre	25
Chimenea modular inox-galvanizado	25
Ficha técnica diámetros 350-700	26
Tubería de grandes diámetros 350-700	27-35

Index

Page

<i>Instructions assembly modular chimney</i>	6-7
<i>Graphic to determine the chimney diameter</i>	8
<i>Form sizing</i>	9
<i>Calculation to defect in degree</i>	10-13
<i>Technical data diameters 80-300</i>	14
<i>Modular double wall diameters 80-300</i>	15-24
<i>Double wall pipe. Copper-inox</i>	25
<i>Double wall pipe. Galvanized-inox</i>	25
<i>Technical data diameters 350-700</i>	26
<i>Big diameters pipes 350-700</i>	27-35

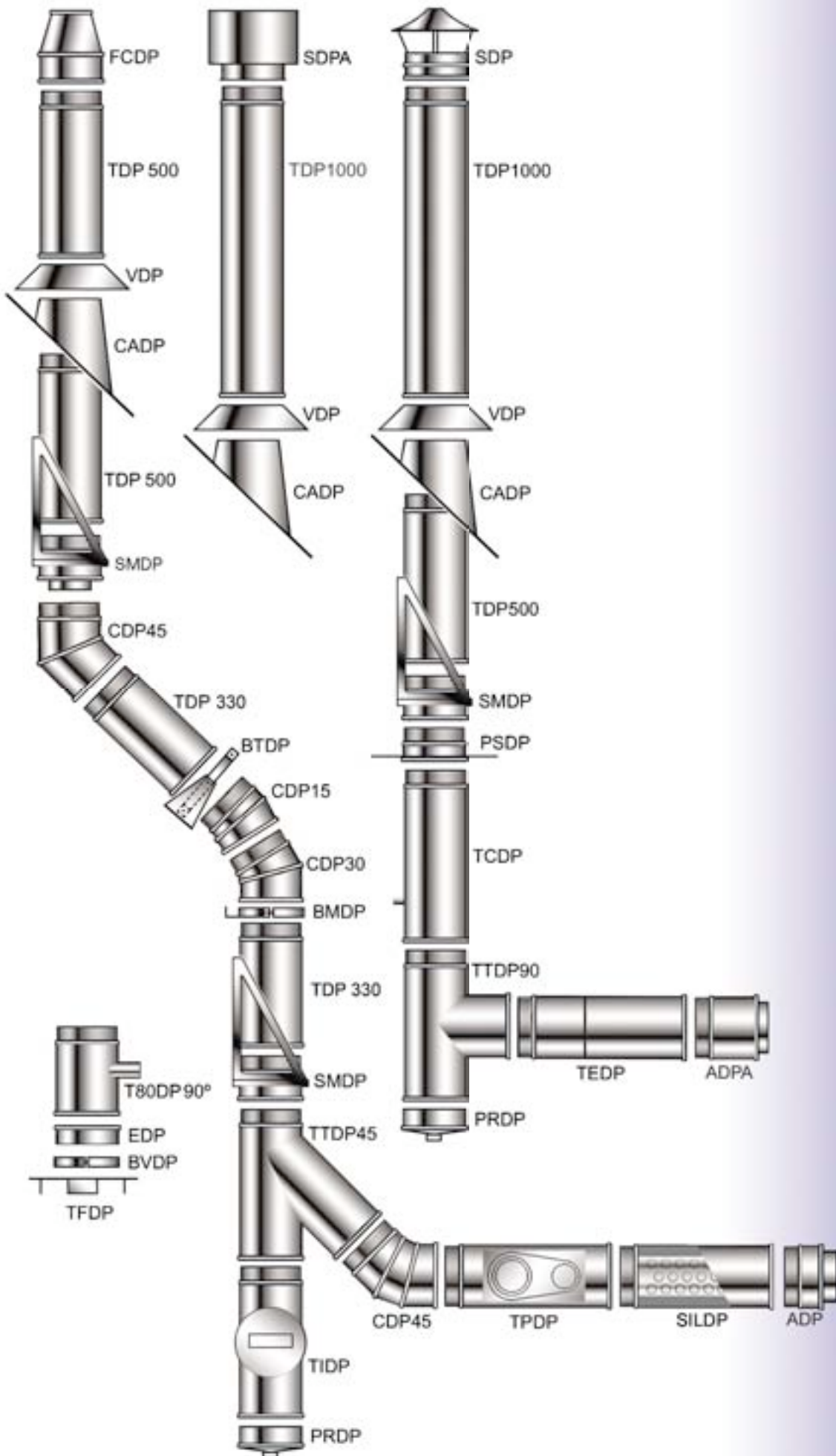

Instrucciones montaje chimenea modular metálica doble pared de Bofill

Para instalar correctamente una chimenea es necesario seguir las siguientes recomendaciones básicas:

- la tubería tiene que colocarse en el correcto sentido de los humos, según la flecha indicadora hacia arriba.
- Para el correcto acoplamiento de los elementos, acoplar macho-hembra y añadir la brida de unión (BRIU) con cierre de seguridad que cada elemento ya lleva incluido.
- Si hay que atravesar un tejado, colocar un cubrechimeneas (CADP) con el correspondiente vierteaguas (VDP) sellado con silicona.
- Para la comprobación de la temperatura de los humos en el interior de la chimenea instalar un tubo comprobación (TCDP) y para la limpieza o facilitar el acceso al conducto interior, instalar un tubo inspección (TIDP).

Para sujetar y asegurar una correcta instalación:

- Colocar siempre un soporte mural (SMDP) con los laterales hacia arriba al inicio de la instalación y otro cada 10 metros, de tubería vertical o después de un codo, una té o un elemento extensible.
- Colocar una brida mural (BMDP) cada 4 metros en tramos verticales y cada 1,5 metros en tramos horizontales para las chimeneas de ϕ 80 a 300 mm y cada 2,5 metros para las de mayor diámetro.
- Colocar una brida de vientos (BVDP) en caso que la chimenea salga más de 1,5 metros de la coronación del tejado.

Instructions assembly double wall modular chimney of Bofill

In order to install correctly a chimney it is necessary to follow some basic recommendations:

- The pipe must be installed in the correct sense of the smoke, according to the indicating arrow upwards.
- For the correct connection of the elements, connect male-female and add the union clamp (BRIU) that each element takes included.
- In case of cross a tile roof, place a chimney sleeve (CADP) with the corresponding flashing (VDP) sealed with silicone.
- For the verification of the temperature of the smoke inside the chimney install a verification pipe (TCDP) and for cleaning or to facilitate the access to the inner conduit, install an inspection tee (TIDP).

In order to hold and to assure a correct installation:

- Place always a mural support (SMDP) with the laterals upwards at the beginning of the installation and another one each 10 meters of vertical pipe or after an elbow, a tee or a telescopic element.
- Place a mural bracket (BMDP) each 4 meters in vertical sections and each 1,5 meters in horizontal sections for chimneys between ϕ 80 and ϕ 300 mm and each 2,5 meters for bigger diameters.
- Place a wind clamp (BVDP) in case the chimney leaves more than 1,5 meters the top of the tile roof.

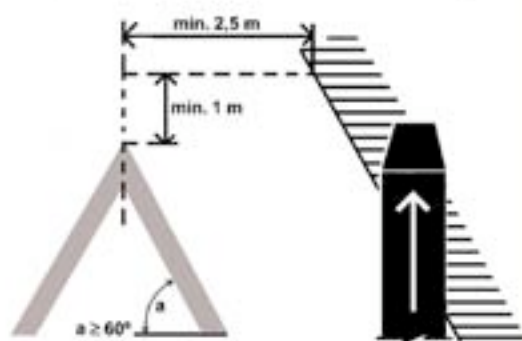
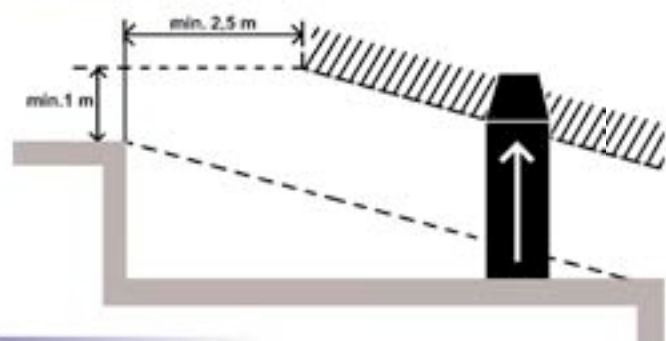
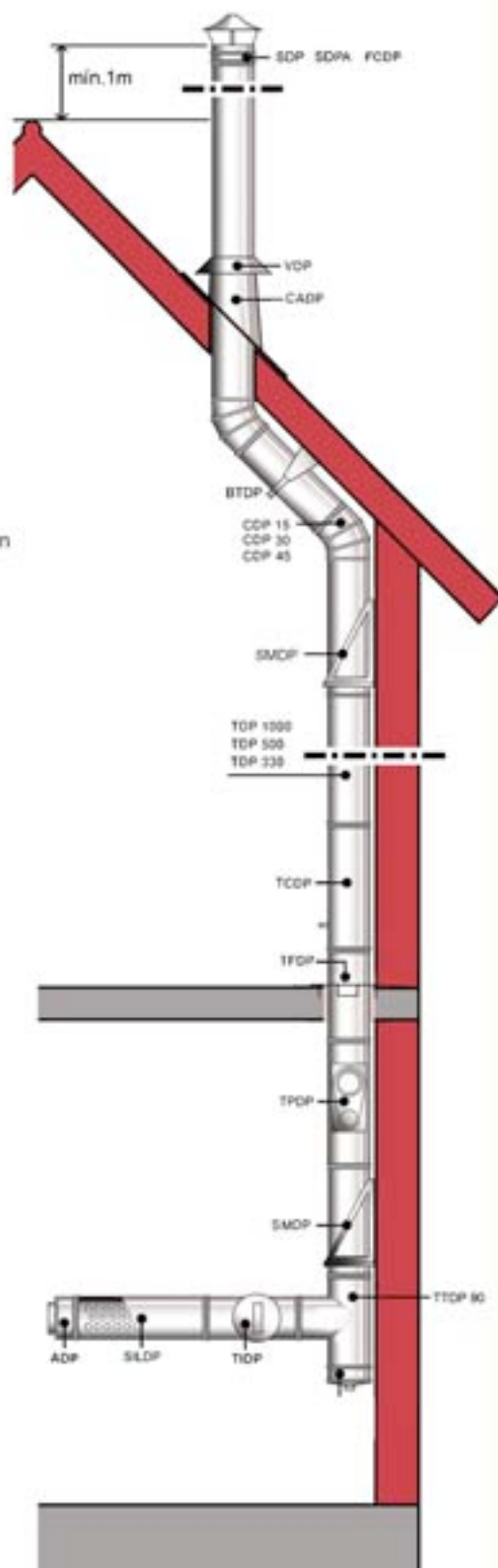

Gráfica para determinar el diámetro de la chimenea.
Grafic to determine the chimney diameter.

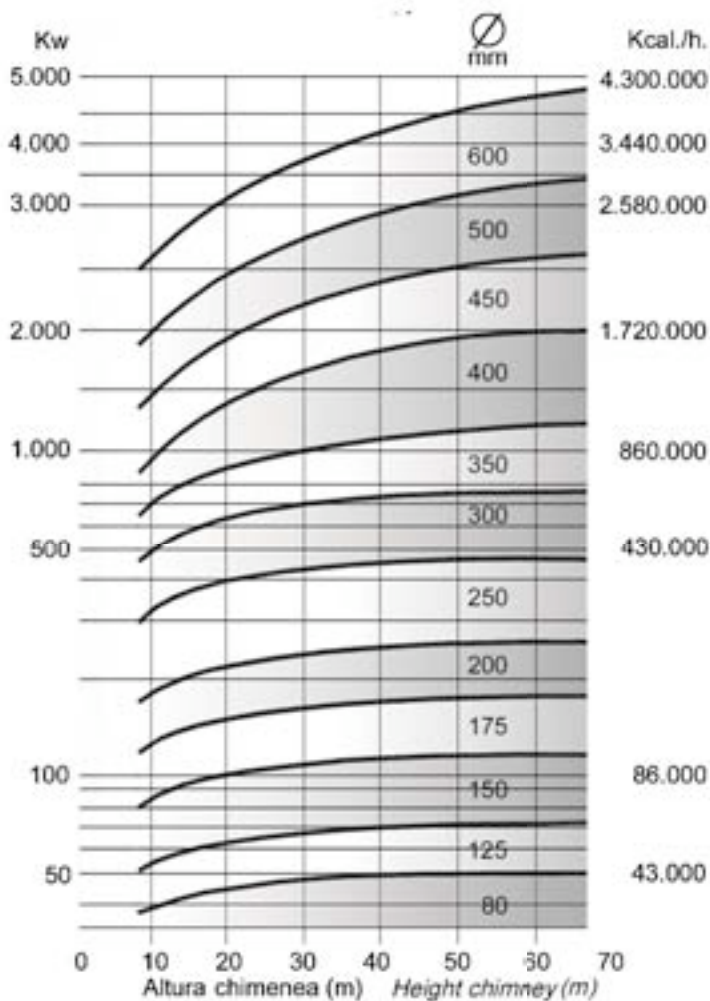

Para un cálculo más preciso contactar con nuestro departamento de ingeniería.
 Contact with our engineering department for mor precise calculation.

Bofill no se responsabiliza de la selección de un diámetro concreto por parte de usuario.
 Bofill does not take responsibility if the user selects a concrete diameter.

Formulario dimensionamiento chimenea *Form sizing chimney*

DATOS CALDERA / *Heating appliances:*

Tipo / *Type of heating appliance:*
 Potencia / *Power (KW):*
 Tipo de quemador / *Type of burner regim*
 Combustible
 Temperatura humos / *Fumes temperature:*
 Diámetro salida / *Outlet fumes diameter:*

TRAMO VERTICAL / *Vertical chimney*

Altura eficaz / *Effective height H_u (m):*
 Desplazamiento del eje vertical /
Offset from the vertical axes S (m) :
 Altura inicio desplazamiento / *height start offset $H1$ (m)*
 Elementos curva / *Type of elbow for the offset:*
 Colocación (interna / externa) / *Collocation (inside/outside):*
 Sombrerete / *Rain cap:*
 Té / *Te pipe (45°/90°):*

TRAMO HORIZONTAL / *Connecting pipe:*

Longitud / *Lenght L (m):*
 Altura / *Height $H2$ (m):*
 Curvas / *Elbows (15°/30°/45°/90°):*
 Colocación (interior/exterior) / *Collocation (inside/outside):*

DATOS AMBIENTALES / *Environment data*

Localización (provincia) / *Town :*
 Altura sobre el nivel del mar / *Altitude (m):*
 Temperatura media / *Average air temperature (°C):*

Poligono Industrial Vilaseca,1
 Tel. 0034 938 593 511
 Fax 0034 938 593 300
 08571 Sant Vicenç de Torelló
 (Barcelona) SPAIN
 E-mail: info@ffbofill.com
 www.ffbofill.com

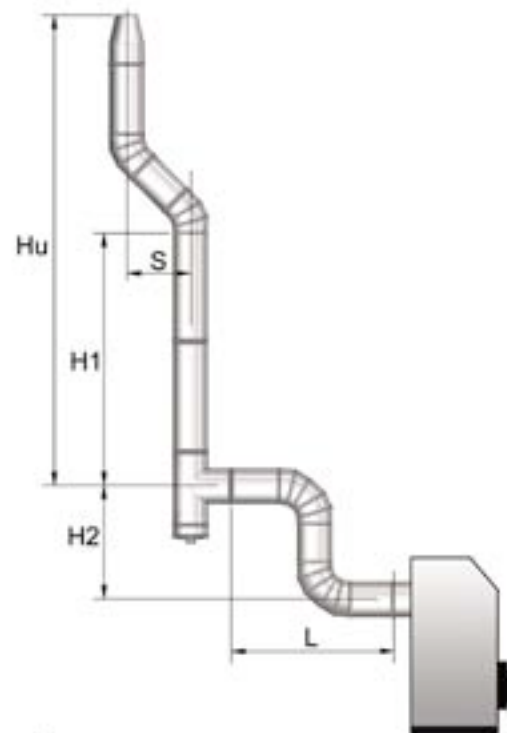

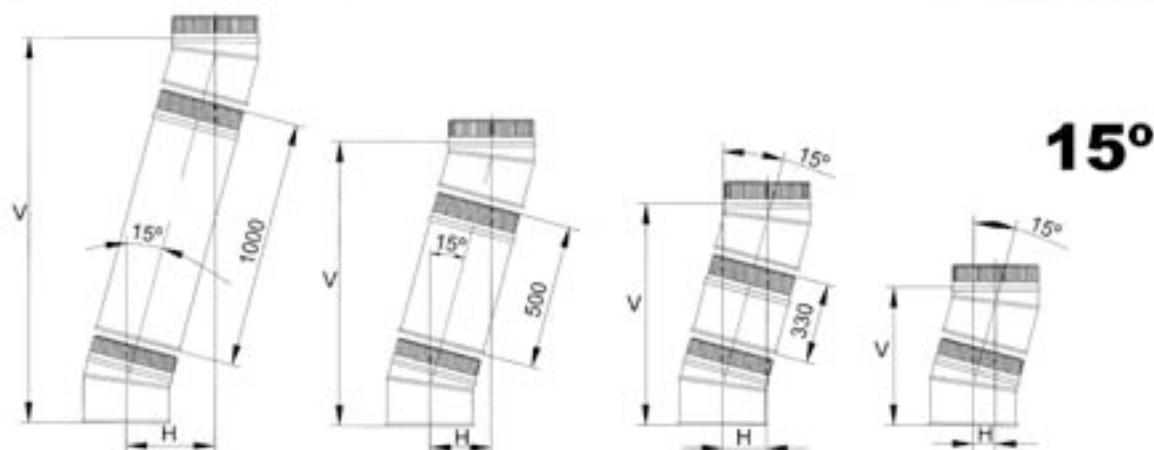

15°

2CDP15 + TDP1000

∅	V	H
80	1231	285
125	1164	276
150	1177	278
175	1190	280
200	1213	283
250	1230	285
300	1237	286

2CDP15 + TDP500

∅	V	H
80	748	156
125	681	147
150	694	149
175	707	150
200	730	153
250	747	156
300	754	157

2CDP15 + TDP330

∅	V	H
80	588	113
125	522	104
150	535	106
175	548	108
200	571	111
250	588	113
300	594	114

2CDP15

∅	V	H
80	328	43
125	261	34
150	274	36
175	287	38
200	310	41
250	327	43
300	334	44

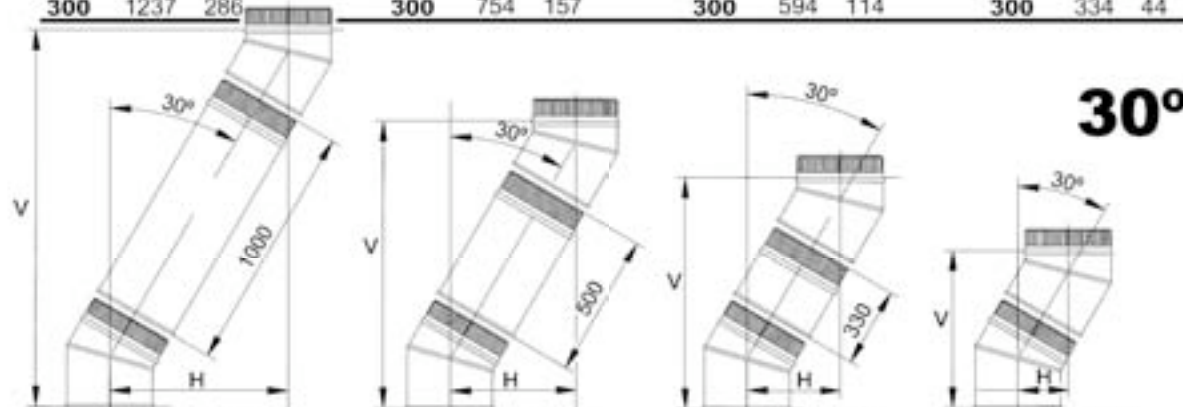

30°

2CDP30 + TDP1000

∅	V	H
80	1125	552
125	1119	550
150	1138	555
175	1154	560
200	1169	564
250	1191	570
300	1203	573

2CDP30 + TDP500

∅	V	H
80	692	302
125	686	300
150	705	305
175	721	310
200	736	314
250	758	320
300	770	323

2CDP30 + TDP330

∅	V	H
80	549	219
125	543	218
150	562	223
175	578	227
200	593	231
250	615	237
300	627	240

2CDP30

∅	V	H
80	315	84
125	309	83
150	328	88
175	344	92
200	359	96
250	381	102
300	393	105

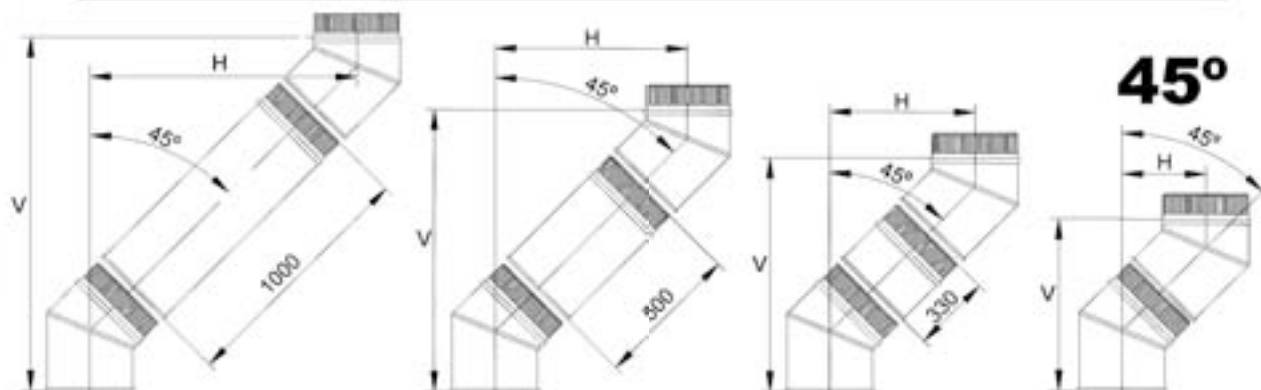

45°

2CDP45 + TDP1000

∅	V	H
80	951	781
125	991	798
150	1002	802
175	1020	810
200	1036	817
250	1070	830
300	1111	847

2CDP45 + TDP500

∅	V	H
80	597	427
125	638	444
150	648	449
175	666	456
200	683	463
250	716	477
300	757	494

2CDP45 + TDP330

∅	V	H
80	480	311
125	521	328
150	531	332
175	550	340
200	566	346
250	599	360
300	641	377

2CDP45

∅	V	H
80	289	120
125	330	137
150	341	141
175	359	149
200	375	155
250	408	169
300	450	186

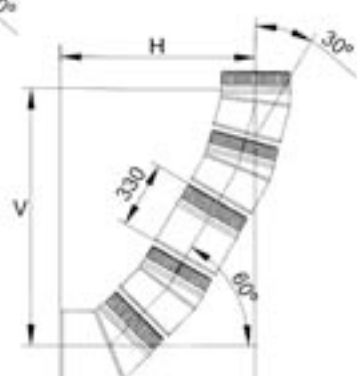
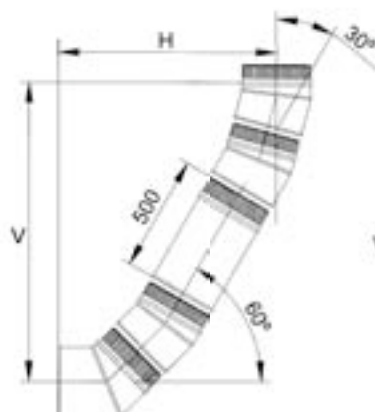
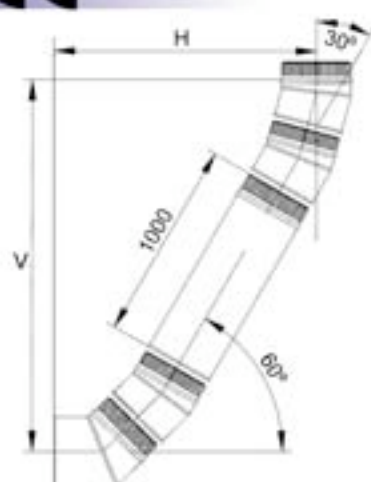
15°
CDP45 + CDP15 + TDP1000 + 2CDP15

Ø	V	H
80	1289	825
125	1201	811
150	1222	826
175	1241	844
200	1280	863
250	1309	888
300	1323	913

CDP45 + CDP15 + TDP500 + 2CDP15

Ø	V	H
80	856	575
125	768	561
150	789	576
175	808	584
200	847	613
250	876	638
300	890	663

CDP45 + CDP15 + TDP330 + 2CDP15

Ø	V	H
80	713	492
125	577	451
150	646	494
175	665	511
200	704	530
250	733	555
300	747	581

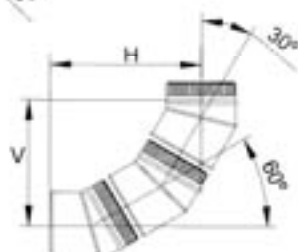
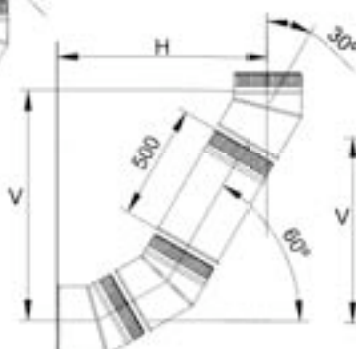
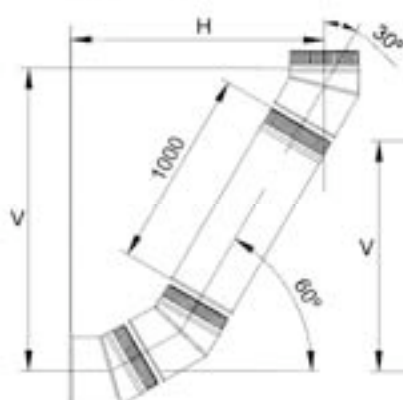
30°
2CDP30 + TDP1000 + CDP30

Ø	V	H
80	1100	808
125	1081	815
150	1102	832
175	1129	836
200	1136	860
250	1156	884
300	1166	897

2CDP30 + TDP500 + CDP30

Ø	V	H
80	667	558
125	648	565
150	669	582
175	696	586
200	703	610
250	723	633
300	733	647

2CDP30 + TDP330 + CDP30

Ø	V	H
80	524	475
125	505	483
150	526	499
175	553	503
200	560	527
250	580	551
300	590	565

3CDP30

Ø	V	H
80	290	340
125	271	348
150	292	364
175	319	368
200	326	392
250	346	416
300	356	430

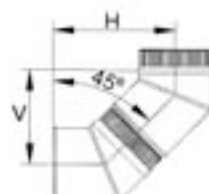
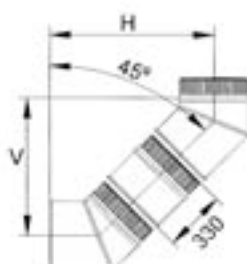
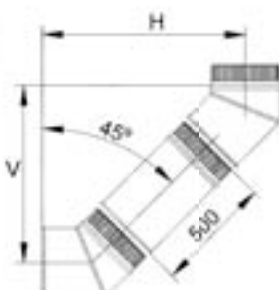
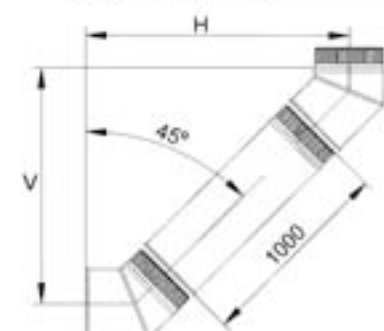
45°
2CDP45 + TDP1000

Ø	V	H
80	837	895
125	859	929
150	870	934
175	879	951
200	895	958
250	917	982
300	942	1016

2CDP45 + TDP500

Ø	V	H
80	483	541
125	506	576
150	516	581
175	525	588
200	542	604
250	564	629
300	589	663

2CDP45 + TDP330

Ø	V	H
80	367	425
125	389	460
150	400	464
175	408	481
200	425	489
250	447	512
300	472	546

2CDP45

Ø	V	H
80	176	234
125	198	269
150	209	273
175	217	290
200	234	297
250	256	321
300	281	355

90°

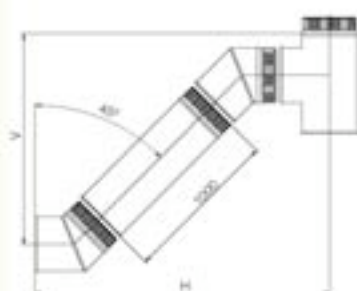

2 CDP45 + TDP1000 + TTDP90

ø	V	H
80	901	096
125	940	1159
150	957	1182
175	977	1213
200	977	1241
250	1035	1300
300	1077	1366

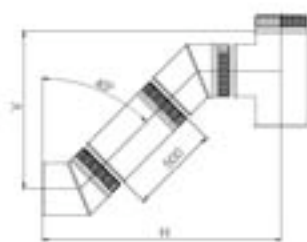

2 CDP45 + TDP500 + TTDP90

ø	V	H
80	547	742
125	587	742
150	604	828
175	624	859
200	643	888
250	682	946
300	724	1012



2 CDP45 + TDP330 + TTDP90

ø	V	H
80	430	625
125	470	689
150	487	711
175	507	742
200	526	771
250	565	829
300	607	896

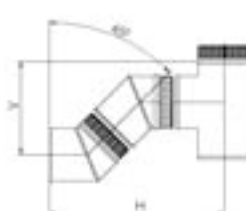

2 CDP45 + TDP45 + TTDP90

ø	V	H
80	240	434
125	279	434
150	296	521
175	316	551
200	335	580
250	374	638
300	416	705

90°

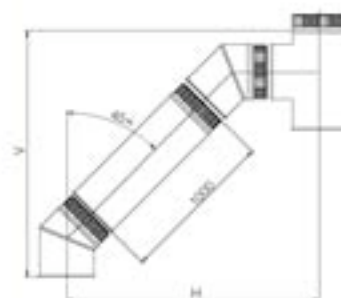

2 CDP45 + TDP1000 + TTDP90

ø	V	H
80	1015	982
125	1072	1027
150	1089	1050
175	1119	1071
200	1138	1100
250	1187	1147
300	1246	1197

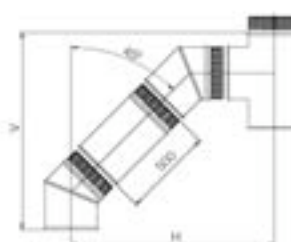

2 CDP45 + TDP500 + TTDP90

ø	V	H
80	661	628
125	719	673
150	735	696
175	765	718
200	784	747
250	834	794
300	893	844

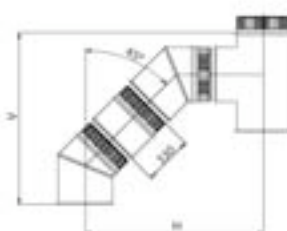

2 CDP45 + TDP330 + TTDP90

ø	V	H
80	544	512
125	602	557
150	619	580
175	648	601
200	668	630
250	717	677
300	1246	1197

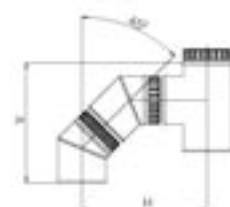

2 CDP45 + TDP45 + TTDP90

ø	V	H
80	354	321
125	411	366
150	428	389
175	458	410
200	477	439
250	526	486
300	585	536

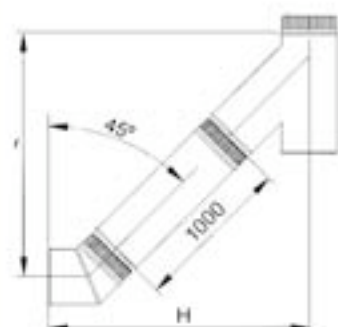

CDP45 + TDP1000 + TTDP45

Ø	V	H
80	837	895
125	859	929
150	870	934
175	879	951
200	895	958
250	917	982
300	942	1016

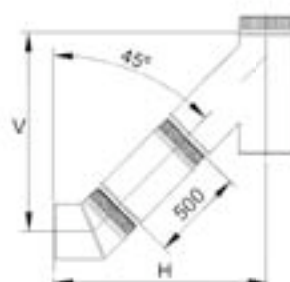

CDP45 + TDP500 + TTDP45

Ø	V	H
80	645	683
125	696	747
150	731	773
175	755	804
200	788	832
250	847	892
300	905	957

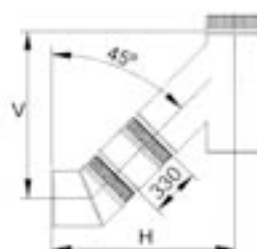

CDP45+ TDP330 + TTDP45

Ø	V	H
80	528	570
125	580	630
150	614	659
175	638	688
200	671	716
250	730	775
300	789	840

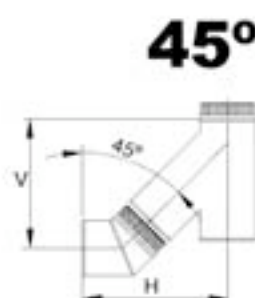

CDP45+TTDP45

Ø	V	H
80	337	379
125	389	439
150	423	469
175	447	497
200	480	525
250	539	584
300	598	649

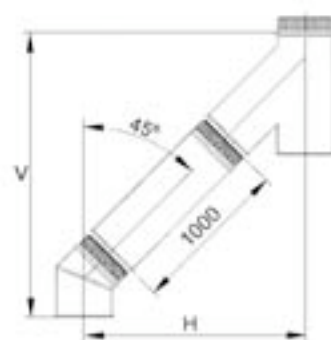

CDP45 + TDP1000 + TTDP45

Ø	V	H
80	951	781
125	991	798
150	1002	802
175	1020	810
200	1036	817
250	1070	830
300	1111	847

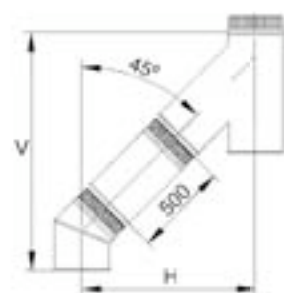

CDP45 + TDP500 + TCP45

Ø	V	H
80	758	573
125	828	615
150	863	644
175	896	663
200	929	691
250	999	740
300	1074	788

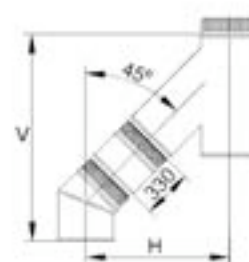

CDP45 + TDP330 + TTDP45

Ø	V	H
80	642	456
125	712	498
150	746	528
175	779	546
200	813	574
250	882	623
300	958	671

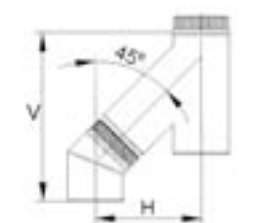

CDP45 + TTDP45

Ø	V	H
80	451	265
125	521	307
150	555	337
175	588	355
200	622	383
250	692	432
300	767	480

Ficha Técnica *Technical data*

Ø 80 - Ø 300 mm

Chimenea modular doble pared de acero inoxidable

La chimenea policomcombustible modular F.F. Bofill, está constituida básicamente por dos cilindros concéntricos de acero inoxidable, que cierran por los extremos, una cámara aislante rellena de lana de roca de 30 mm de espesor y densidad 125 kg/m³ y con arandelas de 50 mm de espesor y densidad 175 kg/m³ que la presionan por los extremos.

Modular stainless steel, double-wall stove pipes chimney

The F.F. Bofill modular, multi-fuel chimney is basically produced of two concentric stainless steel cylinders which are close at both ends with an insulating chamber filled with 30 mm thick and 125 kg/m³ dense rock wool and two 50 mm thick and 175 kg/m³ washers.

Características Generales *General Characteristics*

Diámetro interior <i>Internal diameter</i>	80	125	150	175	200	250	300
Diámetro exterior <i>External diameter</i>	140	185	210	235	260	310	360

Materiales *Materials*

Pared interior <i>Internal wall</i>	Material: Acero inoxidable <i>Stainless steel</i>	AISI 304 / AISI 316 L
	Espesor <i>Thickness</i>	0.4 mm
Pared exterior <i>External wall</i>	Material: Acero inoxidable <i>Stainless steel</i>	AISI 304 / COBRE / GALVANIZADO AISI 304 / CUPPER / GALVANIZED
	Espesor <i>Thickness</i>	0.4 mm / 0.5 mm
Material del aislamiento <i>Isolation material</i>	Lana de roca, espesor 30 mm, densidad 125 kg/m ³ <i>Rock wool, 30 mm thick and 125 kg/m³ density</i>	
Tipo de unión <i>Union</i>	Macho-hembra (con brida) <i>Male-female (with clamp)</i>	

Designación según norma EN 1856-1 / *Designation*

T160 P1 W V2 L50040 O (50)	con junta de silicona <i>with silicone joint</i>
T450 N1 D V2 L50040 G (50)	sin junta de silicona <i>without silicone joint</i>

Conformidad *Conformity*

Norma /Norm UNE - EN 1856-1: 2004

Certificación *Certification*

Marca N de AENOR
CE n° 0099/CPD/A71/002



Chimenea modular aislada de doble pared
Double wall isolated modular chimney

ø 80 125 150 175 200 250 300 mm

Con junta de silicona / With silicone joint: T160 P1 W V2 L50040 O50

Sin junta de silicona / Without silicone joint: T450 N1 D V2 L50040 G50



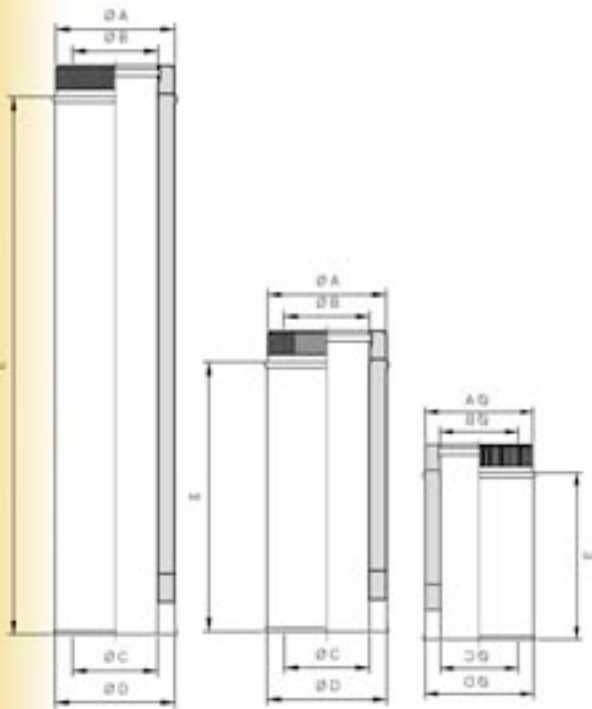

Tubo
Pipe

TDP

ø	A	B	C	D	E
80	139	82	80	140	
125	184	127	125	185	935
150	209	152	150	210	
175	234	177	175	235	435
200	259	202	200	260	
250	309	252	250	310	270
300	359	302	300	260	

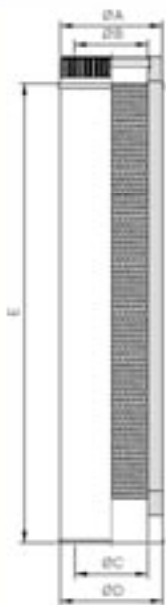

Silenciador
Silencer

SILD

ø	A	B	C	D	E
125	184	127	125	185	935
150	209	152	150	210	935
200	259	202	200	260	935
250	309	252	250	310	935
300	359	302	300	360	935



TEDPL

TEDP

Tubo extensible
Extensible pipe

ø	A	B	C	D
80	139	82	80	140
125	184	127	125	185
150	209	152	150	210
175	234	177	175	235
200	259	202	200	260
250	309	252	250	310
300	359	302	300	360

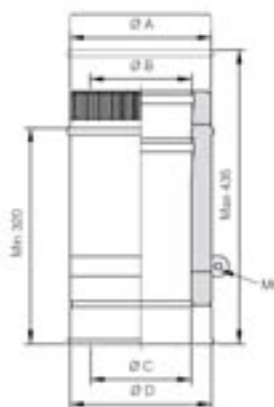
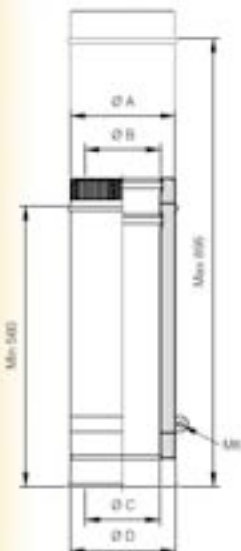



Codo
Elbow



CDP 15

ø	A	B	C	D	E	F
80	139	82	80	140	165	15
125	184	127	125	185	131	9
150	209	152	150	210	138	9
175	234	177	175	235	145	10
200	259	202	200	260	156	12
250	309	252	250	310	164	13
300	359	302	300	360	168	14

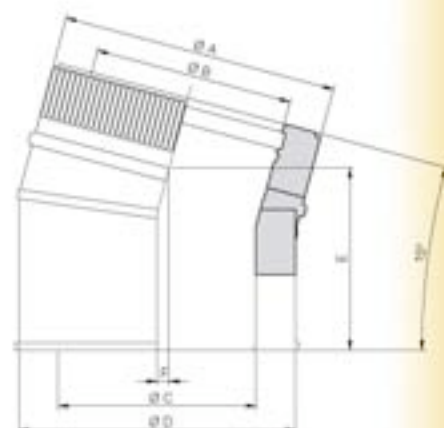

Codo
Elbow



CDP 30

ø	A	B	C	D	E	F
80	139	82	80	140	161	30
125	184	127	125	185	160	22
150	209	152	150	210	169	26
175	234	177	175	235	175	34
200	259	202	200	260	184	32
250	309	252	250	310	195	33
300	359	302	300	360	201	34

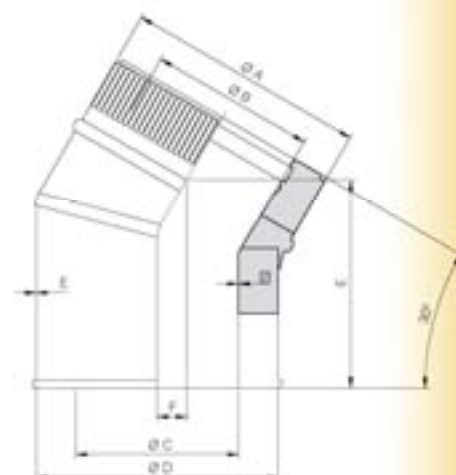

Codo
Elbow



CDP 45

ø	A	B	C	D	E	F
80	139	82	80	140	153	40
125	184	127	125	185	175	43
150	209	152	150	210	180	48
175	234	177	175	235	190	49
200	259	202	200	260	197	56
250	309	252	250	310	214	62
300	359	302	300	360	236	67

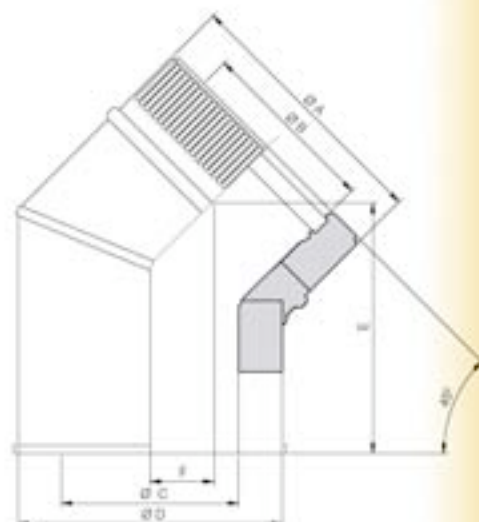

Te
Tee

TTDP 90



ø	A	B	C	D	E	F	G	H	I
80	139	82	80	140	176	174	295	180	110
125	184	127	125	185	198.5	196.5	340	167	75
150	209	152	150	210	211	209	365	180	75
175	234	177	175	235	223.5	221.5	390	192	75
200	259	202	200	260	236	234	415	205	75
250	309	252	250	310	261	259	465	230	75
300	359	302	300	360	286	284	515	255	75

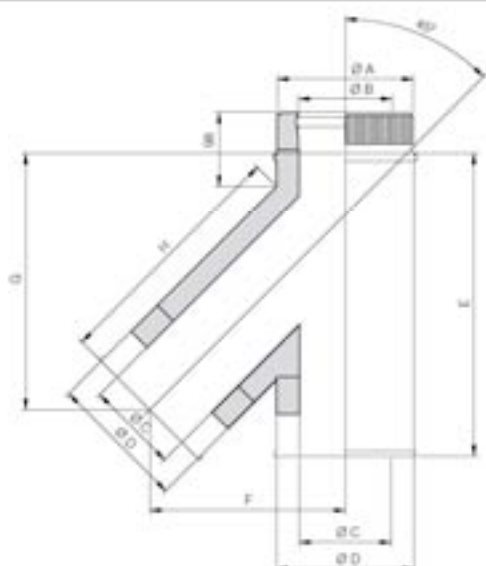

Te
Tee

TTDP 45



ø	A	B	C	D	E	F	G	H
80	139	82	80	140	345	226	298	290
125	184	127	125	185	410	264	345	335
150	209	152	150	210	445	289	375	365
175	234	177	175	235	480	307	398	385
200	259	202	200	260	515	328	425	410
250	309	252	250	310	585	371	478	460
300	359	302	300	360	655	413	531	510

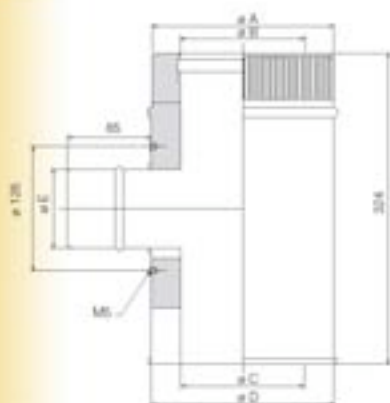

Te SALIDA 80
Tee Ø 80 reduction

T80DP 90

ø	A	B	C	D	E
125	184	127	125	185	80
150	209	152	150	210	80
175	234	177	175	235	80
200	259	202	200	260	80
250	309	252	250	310	80
300	359	302	300	360	80





Tubo de comprobación
Inspection section

TCDP

ø	A	B	C	D
80	139	82	80	140
125	184	127	125	185
150	209	152	150	210
175	234	177	175	235
200	259	202	200	260
250	309	252	250	310
300	350	302	300	360

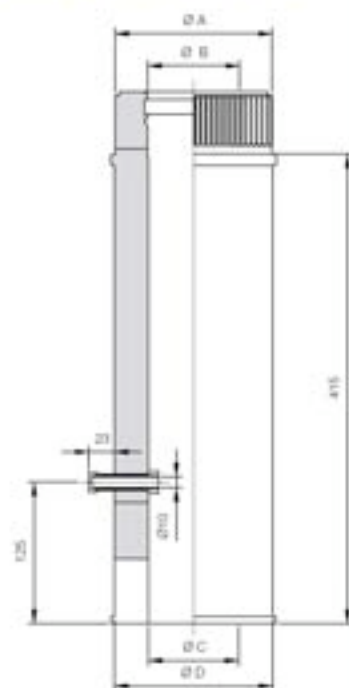

Tubo pirómetro
Pyrometers

TPDP

ø	A	B	C	D
125	184	127	125	185
150	209	152	150	210
175	234	177	175	235
200	259	202	200	260
250	309	252	250	310
300	359	302	300	360

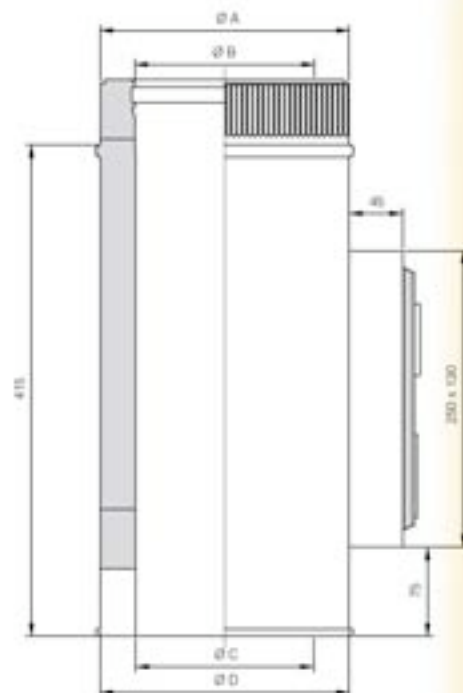

Te de inspección
Inspection tee

TIDP

ø	A	B	C	D	E	F	G	H	I
80	139	82	80	140	176	174	295	180	110
125	184	127	125	185	198.5	196.5	340	167	75
175	234	177	175	235	223.5	221.5	390	192	75
200	259	202	200	260	236	234	415	205	75
250	309	252	250	310	261	259	465	230	75
300	359	302	300	360	286	284	515	255	75

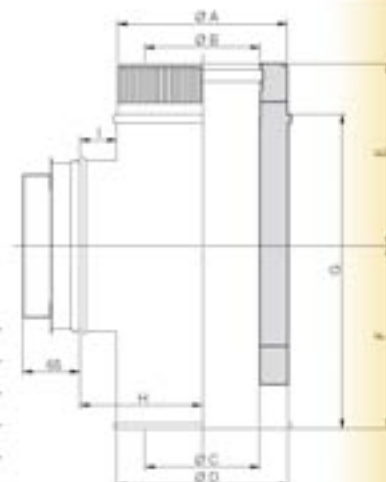

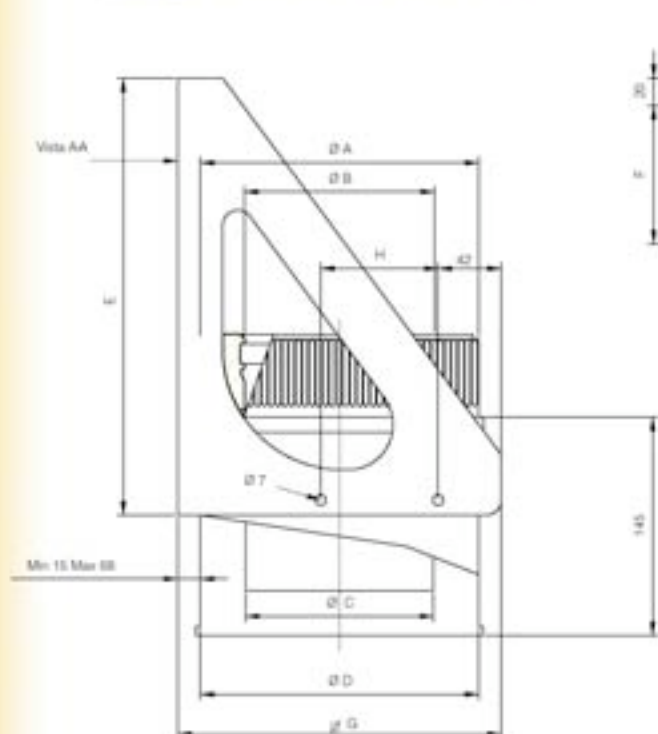

SMDP

Soporte mural
Wall bracket

ø	A	B	C	D	E	F	G	H
80	139	82	80	140	235	97.5	171	54
125	184	127	125	185	290	125	215	78
150	209	152	150	210	315	137.5	240	103
175	234	177	175	235	345	101.6	265	128
200	259	202	200	260	370	110	290	153
250	309	252	250	310	535	165	340	101.5
300	359	302	300	360	600	186.6	390	126.5

PSDP

Soporte de salida
Outlet plate

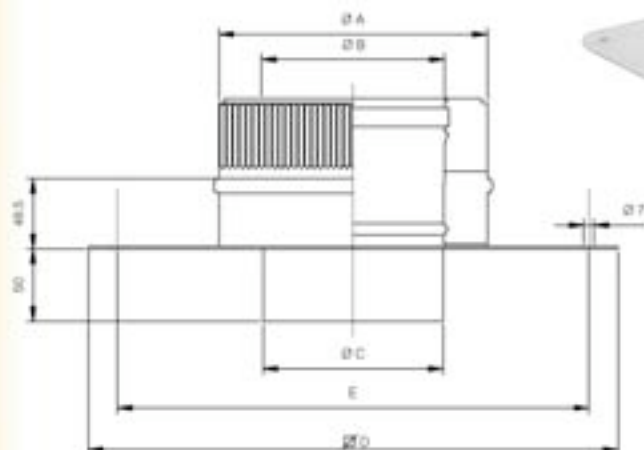

ø	A	B	C	D	E
80	139	82	80	320	280
125	184	127	125	365	325
150	209	152	150	390	350
175	234	177	175	415	375
200	259	202	200	440	400
250	309	252	250	490	450
300	359	302	300	540	500



Brida mural
Wall clamp



BMDP

ø	A	B	øC	E
80	97	205	140	140
125	122	250	185	185
150	137	265	210	210
175	147	300	235	235
200	160	325	260	260
250	186	375	310	310
300	207	425	360	360

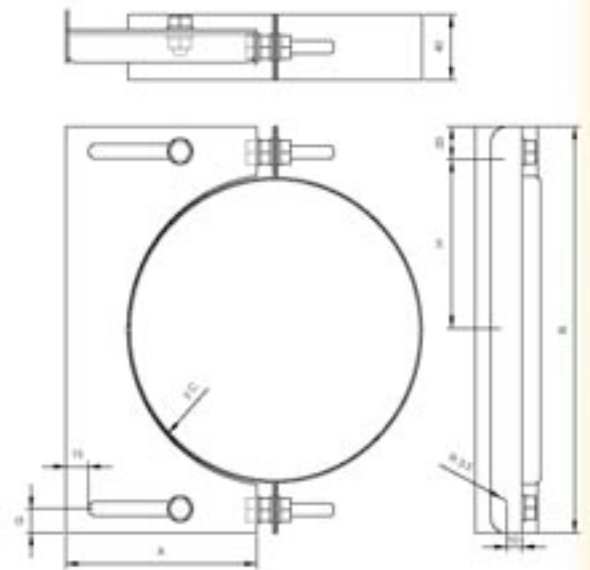

BVDP

Brida viento
Wind clamp



ø	A
80	140
125	185
150	210
175	235
200	260
250	310
300	360

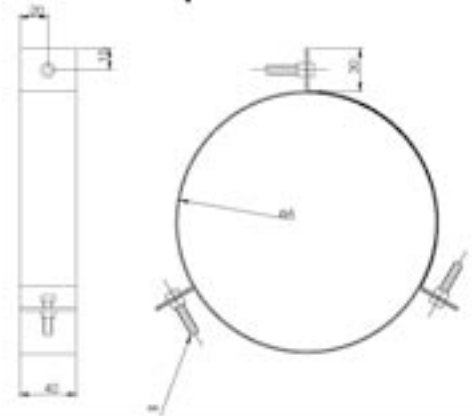

Brida tejado
Roof clamp

BTDP



ø	A
80	140
125	185
150	210
175	235
200	260
250	310
300	360

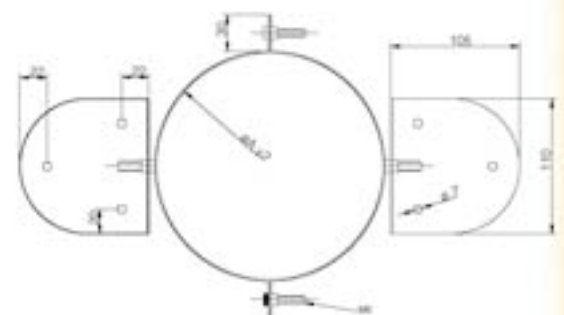

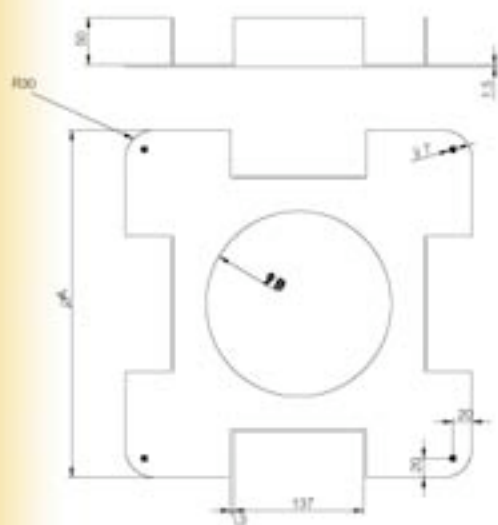

Placa cortafuegos
Fire barrier plate

TFDP

ø	A	B
80	320	150
125	365	195
150	390	220
175	415	245
200	440	270
250	490	320
300	540	370

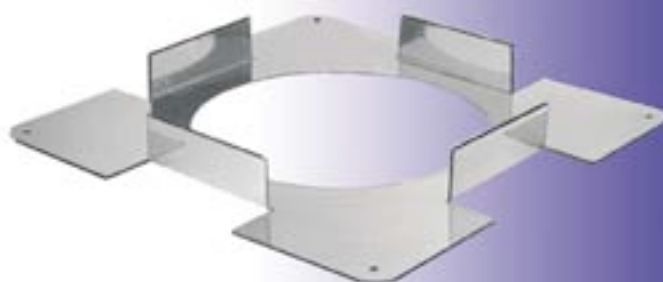

Embellecedor
Ornamenter

EDP

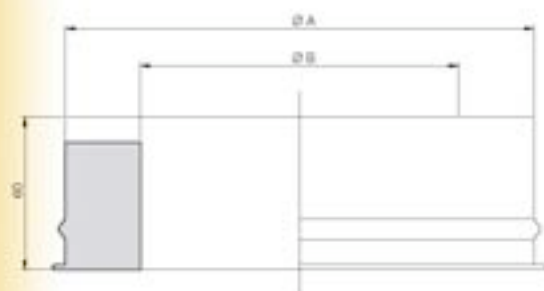

ø	A	B
80	139	82
125	184	127
150	209	152
175	234	177
200	259	202
250	309	252
300	359	302



Adaptador caldera
Boiler adapter

ADP

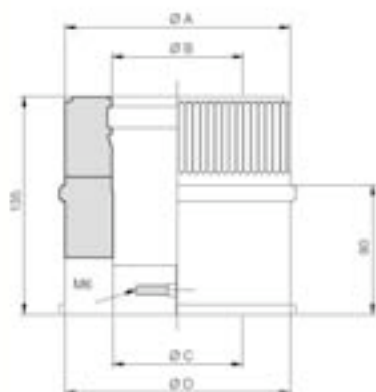

ø	A	B	C	D
80	139	82	80	140
125	184	127	125	185
150	209	152	150	210
175	234	177	175	235
200	259	202	200	260
250	309	252	250	310
300	359	302	300	360





Sombrete Universal
Universal pipe cap



SDP

ø	A	B	C	D
80	140	80	195	165
125	185	125	245	200
150	210	150	300	228
175	235	175	350	240
200	260	200	350	255
250	310	250	500	270
300	360	300	595	290

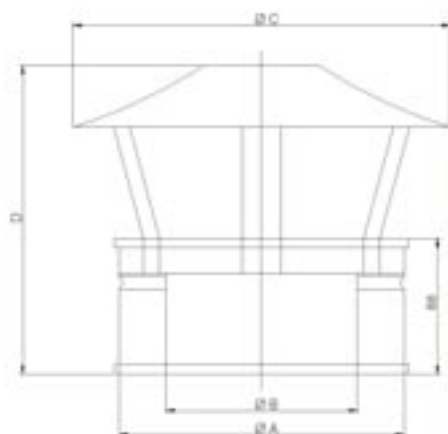

Sombrete antiviento
Windproof cap

SDPA

ø	A	B	C	D	E
80	140	80	240	185	145
125	185	125	280	200	165
150	210	150	305	235	200
175	235	175	335	245	215
200	260	200	355	260	225
250	310	250	440	280	240
300	360	300	500	305	270

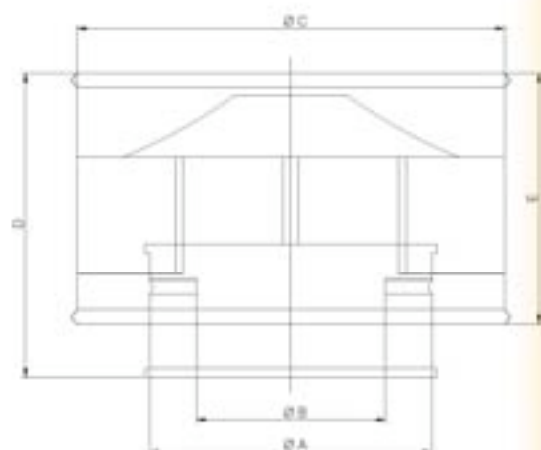

Final cónico
Conical chimney top

FCDP

ø	A	B
80	140	80
125	185	125
150	210	150
175	235	175
200	260	200
250	310	250
300	360	300

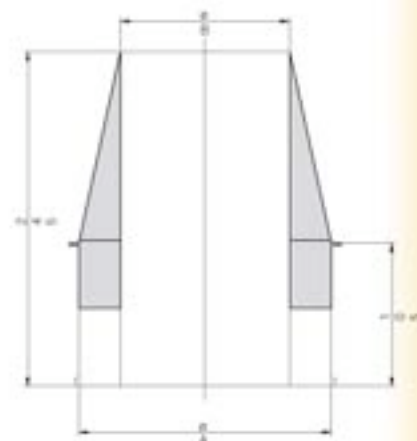

Adaptador caldera ampliado
Extended boiler adapter

ADPA

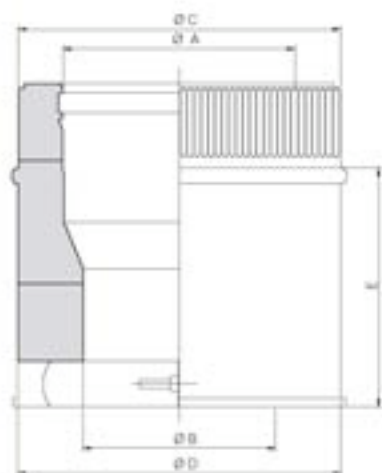

ϕ	A	B	C	D	E
125/150	152	125	149	150	155
125/175	177	125	174	175	185
125/200	202	125	199	200	205
150/175	177	150	174	175	155
150/200	202	150	199	200	180
150/250	252	150	249	250	245
175/200	202	175	199	200	170
200/250	252	175	249	250	178
200/300	302	200	299	300	225
250/300	302	250	299	300	185

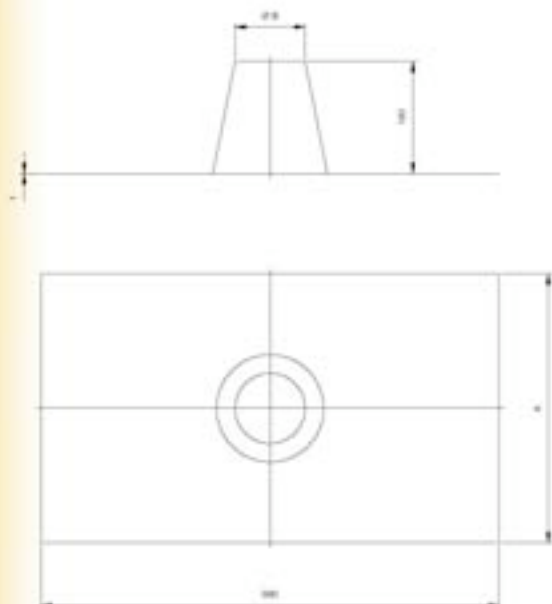

Cubre chimenea
Chimney sleeve

CADP

ϕ	A	B
80	575	150
125	610	195
150	635	220
175	650	245
200	660	270
250	735	320
300	785	370

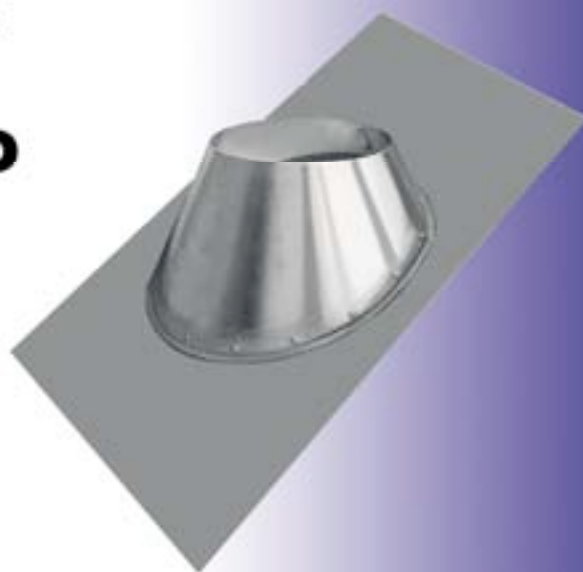

Vierteaguas
Flashing

VDP

ϕ	A	B	C
80	160	280	38
125	205	325	40
150	230	360	42
175	255	395	44
200	280	430	46
250	330	490	48
300	380	550	50



Chimenea modular aislada doble pared inox-cobre
 Pared interior acero inox. Aisi-316. Exterior cobre electrolítico.
 Aislamiento con lana de roca de 30 mm y densidad 125 kg/m³.

Double wall isolated modular chimney inox-copper
 Internal wall of Aisi-316, exterior copper
 A 30 mm layer of rock wool with a density of 125 kg/m³.



Chimenea modular aislada doble pared inox/galvanizado
 Double wall isolated modular chimney inox/galvanized



Ficha Técnica *Technical data*

Ø 350 - Ø 700 mm

Chimenea modular doble pared de acero inoxidable

La chimenea policombustible modular F.F. Bofill, está constituida básicamente por dos cilindros concéntricos de acero inoxidable, que cierran por los extremos, una cámara aislante rellena de lana de roca de densidad 125 kg/m³ de 30 mm de espesor hasta diámetro 500 mm y de 40 mm de espesor a partir de diámetro 550 mm, con arandelas en los extremos de 50 mm de espesor y densidad 175 kg/m³.

Modular stainless steel, double-wall chimney

The F.F. Bofill modular, multi-fuel chimney is basically produced of two concentric stainless steel cylinders which are close at both ends with an insulating chamber filled with rock wool of 125 kg/m³ density 30 mm thick until diameter 500 mm and 40 mm up to 550 mm with two 50 mm thick and 175 kg/m³ washers.

Características Generales

General Characteristics

Diámetro interior <i>Internal diameter</i>	350	400	450	500	550	600	650	700
Diámetro exterior <i>External diameter</i>	410	460	510	560	630	680	730	780

Materiales

Materials

Pared interior <i>Internal wall</i>	Material: Acero inoxidable <i>Stainless steel</i>	AISI 304 / AISI 316 L
	Espesor <i>Thickness</i>	0.5 mm
Pared exterior <i>External wall</i>	Material: Acero inoxidable <i>Stainless steel</i>	AISI 304 AISI 304
	Espesor <i>Thickness</i>	0.5 mm / 0.7 mm
Material del aislamiento <i>Isolation material</i>	Lana de roca de densidad 125 kg/m ³ espesor 30 mm, hasta Ø 500 mm, 40 mm a partir Ø 550 mm densidad 100 kg/m ³ <i>Rock wool of 125 kg/m³ density 30 mm thick and until Ø 500 mm, 40 mm up to Ø 550 mm 100 kg/m³ density</i>	
Tipo de unión <i>Union</i>	Macho-hembra (con brida) <i>Male-female (with clamp)</i>	

Designación según norma EN 1856-1 / *Designation*

T450 N1 D V2 L50050 G (50)

Conformidad

Conformity

Norma /Norm UNE - EN 1856-1: 2004

Certificación

Certification

Marca N de AENOR
CE nº 0099/CPD/A71/001



Tubería de grandes diámetros

Big diameters pipes

Ø 350 400 450 500 550 600 650 700 mm

EN 1856-1 T450 N1 D V2 L50040 G50



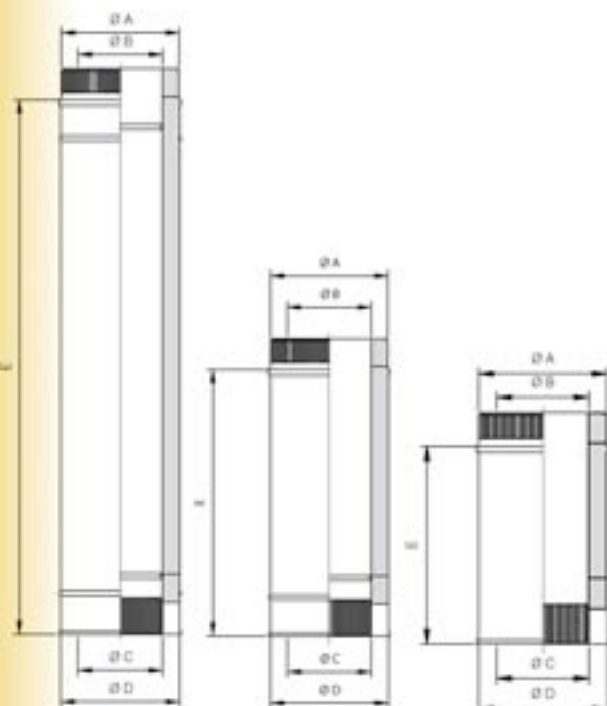

Tubo
Pipe

TDP

ø	A	B	C	D	E
350	409	350	349	410	
400	459	400	399	460	925
450	509	450	449	510	
500	559	500	499	560	
550	629	550	549	630	430
600	679	600	599	680	
650	729	650	649	730	270
700	779	700	699	780	

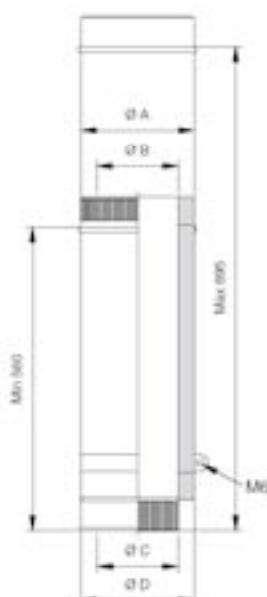

Tubo extensible
Extendible pipe

TEDPL

ø	A	B	C	D
350	409	350	349	410
400	459	400	399	460
450	509	450	449	510
500	559	500	499	560

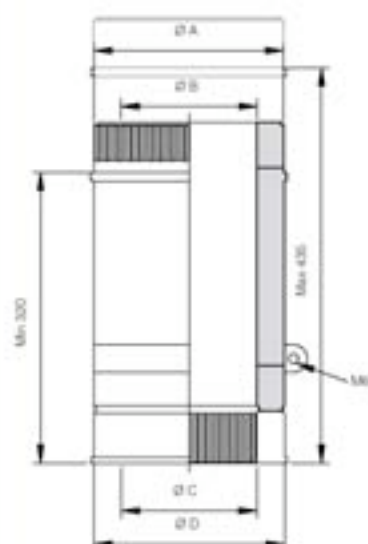

Tubo extensible
Extendible pipe

TEDP

ø	A	B	C	D
350	409	350	349	410
400	459	400	399	460
450	509	450	449	510
500	559	500	499	560
550	629	550	549	630
600	679	600	599	680
650	729	650	649	730
700	779	700	699	780





Codo
Elbow

CDP 15

ø	A	B	C	D	E	F
350	409	350	349	410	223	21
400	459	400	399	460	242	24
450	509	450	449	510	261	27
500	559	500	499	560	282	29

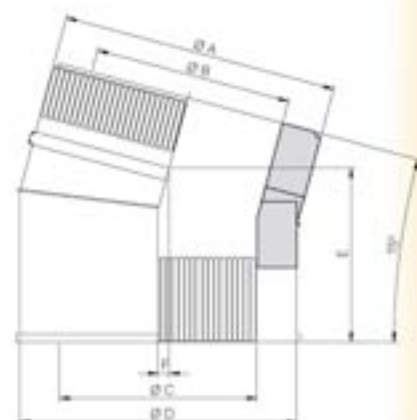

Codo
Elbow

CDP 30

ø	A	B	C	D	E	F
350	409	350	349	410	313	68
400	459	400	399	460	349	78
450	509	450	449	510	386	88
500	559	500	499	560	424	98
550	629	550	549	630	463	109
600	679	600	599	680	499	119
650	729	650	649	730	538	129
700	779	700	699	780	578	139

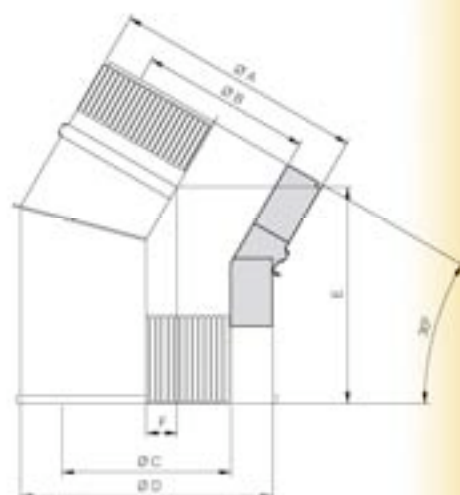

Codo
Elbow

CDP 45

ø	A	B	C	D	E	F
350	409	350	349	410	427	154
400	459	400	399	460	480	175
450	509	450	449	510	533	197
500	559	500	499	560	587	220
550	629	550	549	630	639	241
600	679	600	599	680	692	263
650	729	650	649	730	745	285
700	779	700	699	780	799	307

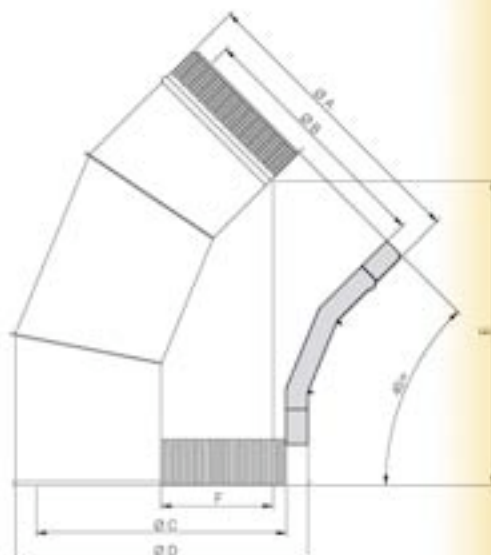

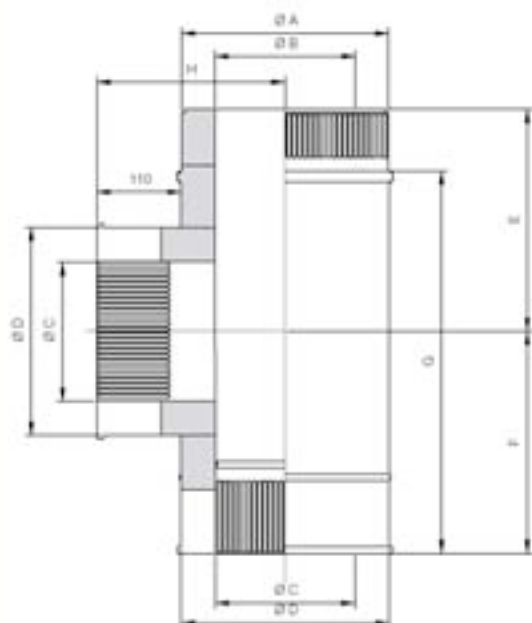

Te
Tee

TTDP 90



ø	A	B	C	D	E	F	G	H
350	409	350	349	410	311	309	566	315
400	459	400	399	460	336	334	616	340
450	509	450	449	510	361	359	666	365
500	559	500	499	560	386	384	716	390
550	629	550	549	630	421	419	786	425
600	679	600	599	680	446	444	836	450
650	729	650	649	730	472	470	888	475
700	779	700	699	780	495	493	933	500

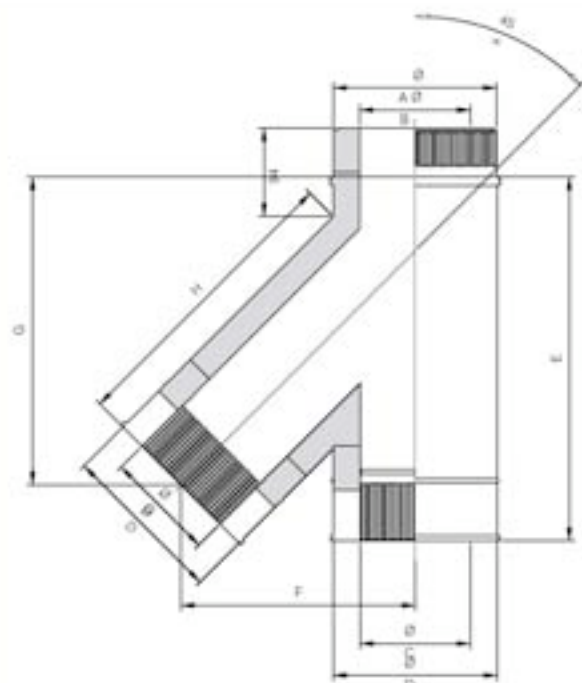

Te
Tee

TTDP 45



ø	A	B	C	D	E	F	G	H
350	409	350	349	410	720	455	581	560
400	459	400	399	460	792	499	633	610
450	509	450	449	510	862	541	686	661
500	559	500	499	560	932	589	744	717
550	629	550	549	630	1016	637	806	770
600	679	600	599	680	1100	686	866	829
650	729	650	649	730	1228	760	950	923
700	779	700	699	780	1356	833	1034	1017



Tubo de comprobación
Inspection section

TCDP

ø	A	B	C	D
350	409	350	349	410
400	459	400	399	460
450	509	450	449	510
500	559	500	499	560

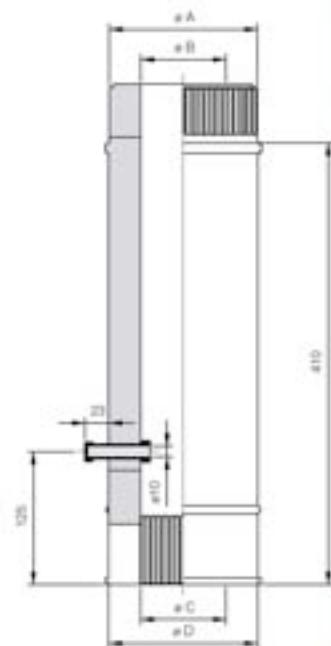

Tubo pirómetro
Pyrometers

TPDP

ø	A	B	C	D
350	409	350	349	410
400	459	400	399	460
450	509	450	449	510
500	559	500	499	560

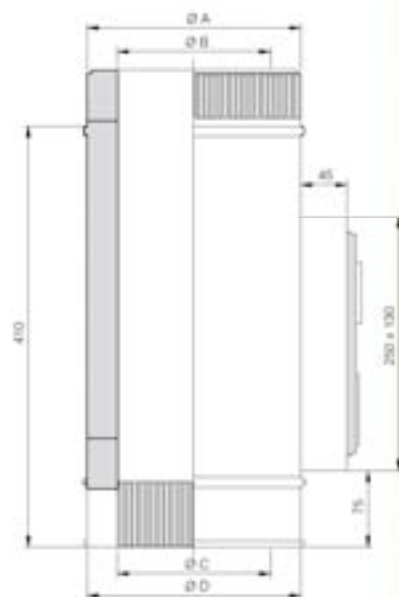

Te de inspección
Inspection tee

TIDP

ø	A	B	C	D	E	F	G	H
350	409	350	349	410	311	309	566	235
400	459	400	399	460	336	334	616	260
450	509	450	449	510	361	359	666	285
500	559	500	499	560	386	384	716	310

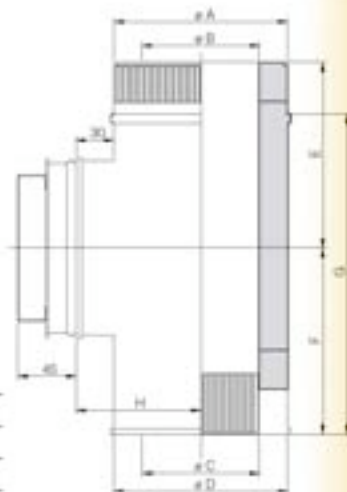

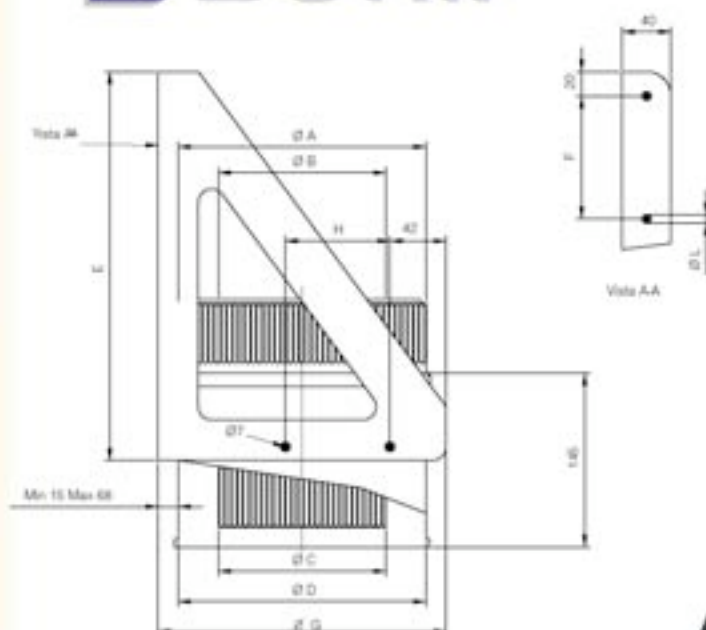

SMDP

Soporte mural
Wall bracket

\varnothing	A	B	C	D	E	F	G	H	I
350	409	350	349	410	660	203.6	440	151.5	7
400	459	400	399	460	730	230	490	176.5	7
450	509	450	449	510	795	251.6	540	201.5	7
500	559	500	499	560	860	273.3	590	226.5	7
550	629	550	549	630	911	217.7	661	262.5	12
600	679	600	599	680	1014	243.5	711	287	12
650	729	650	649	730	1079	253.7	761	312.5	12
700	779	700	699	780	1144	276	811	337.5	12

PSDP

Placa de salida
Outlet plate

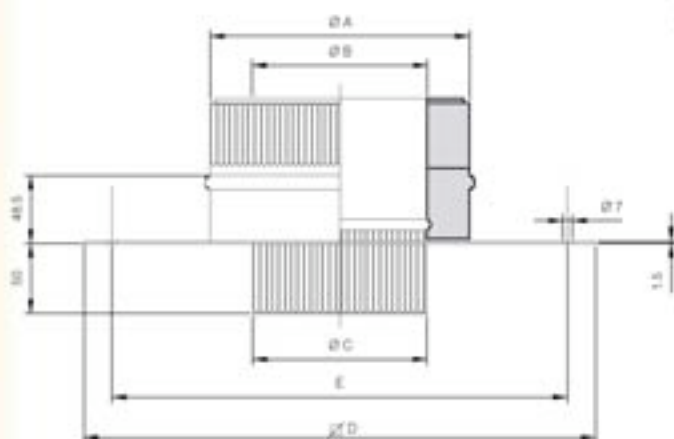

\varnothing	A	B	C	D	E
350	409	350	349	590	550
400	459	400	399	640	600
450	509	450	449	690	650
500	559	500	499	740	700



Brida mural
Wall clamp



BMDP

ø	A	B	øC	D	øE	F	G
350	206	499	7	216	410	20	229.6
400	232	541	7	249	460	25.5	245
450	257	592	7	270	510	26	270
500	282	642	7	295	560	26	295
550	317	712	12	330	630	26	220
600	342	763	12	355	680	26	236.6
650	367	813	12	380	730	26.5	253.3
700	392	870	12	403	780	20	276.7

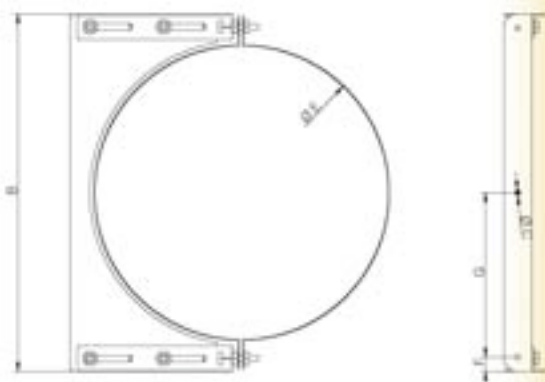

BVDP

Brida viento
Wind clamp



ø	A
350	410
400	460
450	510
500	560
550	630
600	680
650	730
700	780

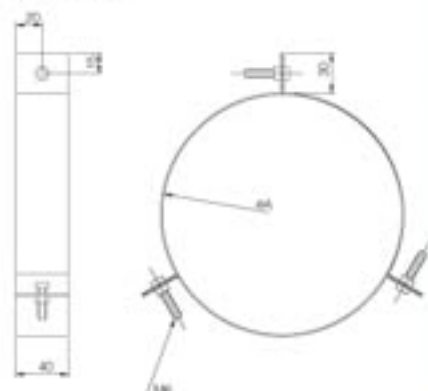

Brida tejado
Roof clamp

BTDP



ø	A
350	410
400	460
450	510
500	560

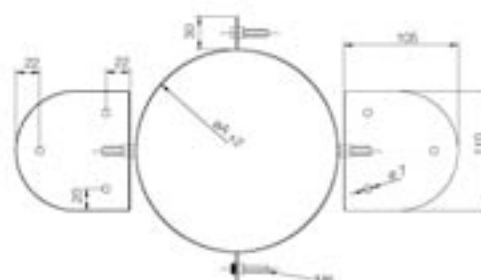

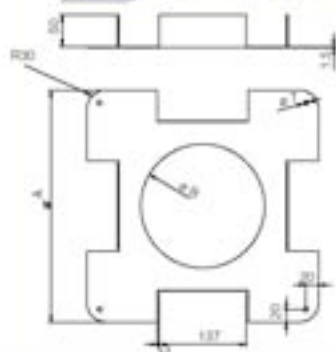

TFDP

ø	A	B
350	590	420
400	640	470
450	690	520
500	740	570

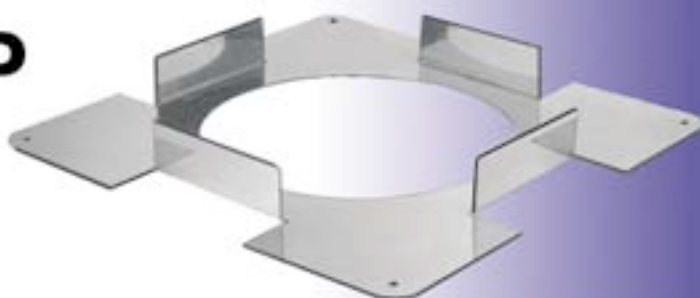

ADP

Adaptador caldera
Boiler adapter

ø	A	B	C	D
350	409	350	349	410
400	459	400	399	460
450	509	450	449	510
500	559	500	499	560
550	629	550	549	630
600	679	600	599	680
650	729	650	649	730
700	779	700	699	780

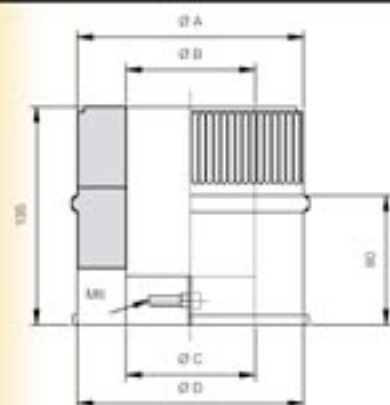

EDP

Embellecedor
Ornamenter

ø	A	B
350	349	350
400	399	400
450	449	450
500	499	500

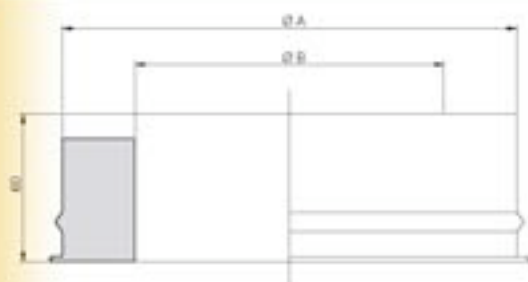
Purga
Water drain

PRDP

ø	A	B	C
350	409	349	130
400	459	399	135
450	509	449	140
500	559	499	145

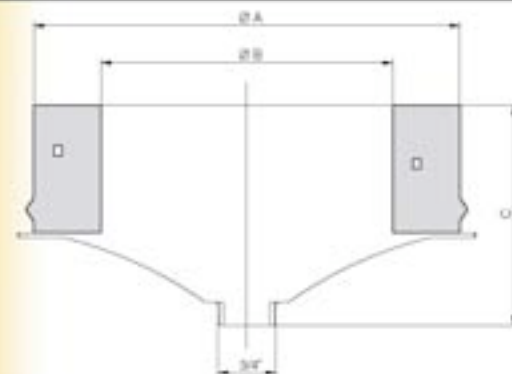
Vierteaguas
Flashing

VDP

ø	A	B	C
350	430	620	50
400	480	670	60
450	530	730	60
500	580	780	65
550	650	840	65
600	700	890	65
650	750	940	70
700	800	990	75





Sombrerete universal
Universal pipe cap



SDP

ø	A	B	C	D
350	410	349	700	320
400	460	399	800	385
450	510	449	800	395
500	560	499	1000	415

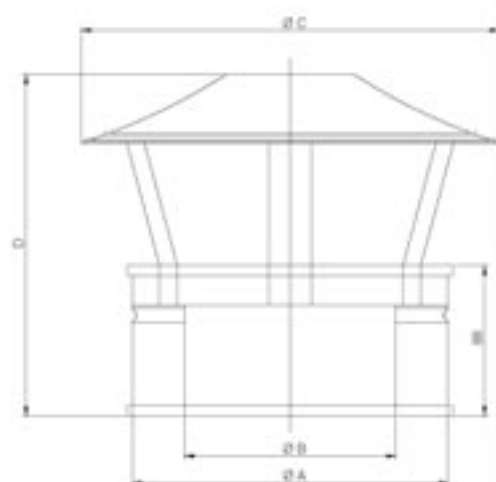

Final cónico
Conical chimney top

FCDP

ø	A	B
350	410	349
400	460	399
450	510	449
500	560	499
550	630	549
600	680	599
650	730	649
700	780	699

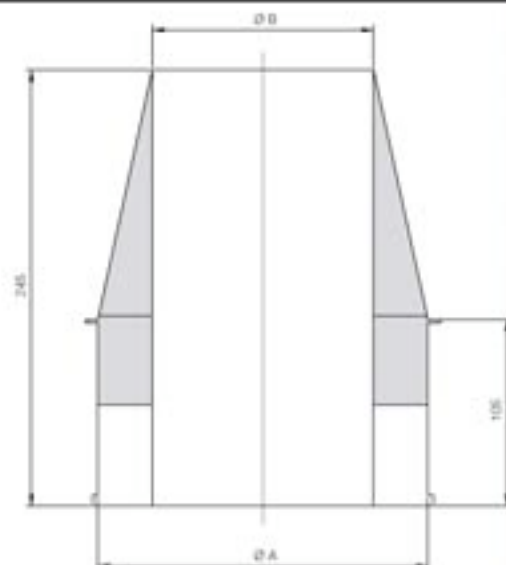

Cubre chimenea
Chimney sleeve

CADP

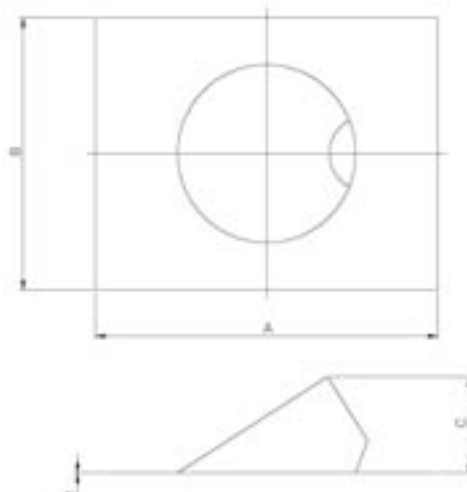
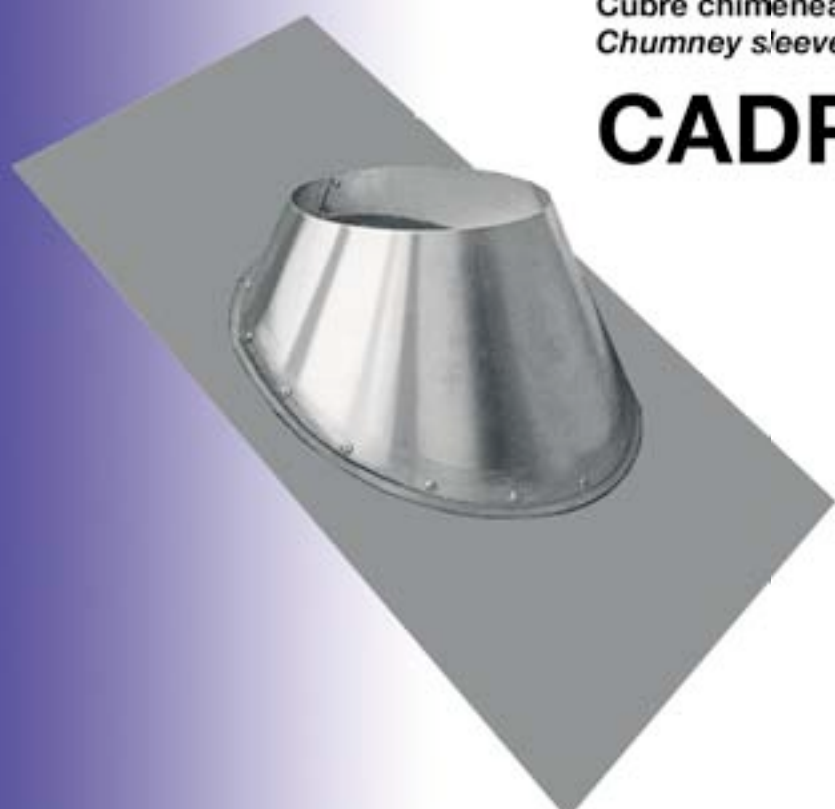

ø	A	B	C
350	980	990	431
400	1200	1200	474
450	1290	1290	517
500	1380	1380	560



Chimenea modular aislada de doble pared
Double wall isolated modular chimney

