

FILTERS
99,95%
OF ALL
VIRUSES



TAP-L WITH BODY RAL
9016

TROX AIR PURIFIER

TO REDUCE THE RISK OF INFECTION BY AEROSOLS AND VIRUSES IN ENCLOSED SPACES

The TROX AIR PURIFIER filters more than 99.95% of all aerosols out of the air and is the high-performance stand-alone solution for effectively reducing the risk of infection. It operates quietly, efficiently and ensures maximum effectiveness with the highest air change rate in its class of units.

- Filters more than 99.95% of aerosols out of indoor air
- High air change rates due to volume flow rates through the unit of up to 1600 m³/h
- Very quiet operation due to double sound attenuation
- Low power consumption with energy-efficient motors
- High-efficiency filter system with 2 filter stages
- Maintenance-free – filter exchange after unit message
- No specialist personnel required for commissioning
- Long service life and efficient operation due to large filter areas
- Intelligent air distribution



TAP-L WITH BODY RAL
7012

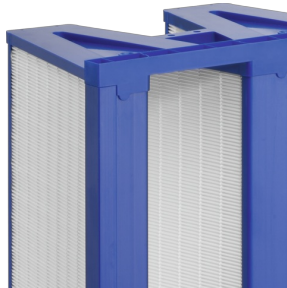

PREFILTER MFI-EPM1 85
%



HEPA FILTER MFI-H13



TESTED TO VDI 6022

General information

Application

The TROX air purifier is used to purify atmospheric air indoors. As a stationary air purifier, the unit ensures a relevant reduction in dust and aerosol concentration in the indoor air. By using a HEPA filter H13, it filters 99.95% of all aerosols out of the air and thus effectively reduces the infection risks. The unit is used for purifying the indoor air in heavily frequented rooms. These include, for example:

- Waiting and reception areas
- Meeting or conference rooms
- Schools
- Trade fair booths
- Dining rooms
- Shops

Special features

- Compact construction
- Easy operation
- High operational reliability
- With regulating unit controlled by volume flow rate:
 - Unit always keeps the selected volume flow rate constant – even with increased air resistance of the fan
 - This ensures that the indoor air is cleaned to the full extent even if the filters become increasingly contaminated

Classification

- Meets the hygiene requirements

Nominal sizes

- Floor-mounted units L (B × H × T 644 × 2313 × 701 mm)
- Floor-mounted units M (B × H × T 644 × 2313 × 441 mm)

Construction

- SPC: galvanised steel powder-coated

Variants

- P1 Surface body powder-coated, colour RAL 7012 20%
- P2 Diffuser surface / base frame powder-coated, colour RAL 7021 20%

Parts and characteristics

- Fan
- Controller for adapting the air change rate
- Filter change alert (red light)
- Mains isolator with green light luminaire "ready for operation"

Air diffusers

- 3-sided aligned blades

Useful additions

- Mini Pleat filter inserts (MFI) included in delivery
- Associated filter inserts as replacement filters must be ordered separately

Construction features

- Prefilter stage and HEPA filter stage
- Sound attenuator before and after fan

Materials and surfaces

- Casing made of powder-coated sheet steel, body RAL 9016 20%, diffuser/base frame RAL 7012 20%

Standards and guidelines

- Hygiene meets the requirements of VDI 6022, VDI 3803, DIN 1946 Part 4, ÖNORM H 6021 and ÖNORM H 6020, SWKI VA 104-01 and SWKI 99-3, and EN 13779

Maintenance

- Filter changes and other maintenance work can only be carried out when plant operation is interrupted
- Air filters can be easily removed and refitted for filter changes

Installation and commissioning

- Opening the door with Allen key size 10

INFORMACIÓN TÉCNICA

Function, Technical data, Quick sizing, Specification text, Order code



The TROX air purifier draws indoor air into the unit at the lower air intake and feeds it to the filters. The prefilter separates coarser particles, then the HEPA filter separates the smallest suspended particles and particles from the room air. A fan conveys the airflow through the unit and returns the filtered air to the room via the upper outlet. Placed in front of and behind the fan

Sound attenuators reduce the operating noise to a pleasant minimum. With its operation, the TROX air purifier ensures a significant reduction in particles and aerosol concentration in rooms.

By the filtering and high air change rates, the air purifier considerably reduces the amount of germs, viruses and bacteria (depending on the room size) and thus also cuts the risk of infection. The air purifier has a regulating unit controlled by volume flow rate. This means the unit always keeps the selected volume flow rate constant – even with increased air resistance of the fan. This ensures that the indoor air is cleaned to the full extent even if the filters become increasingly contaminated and there is a resulting rise pressure drop across the filter.

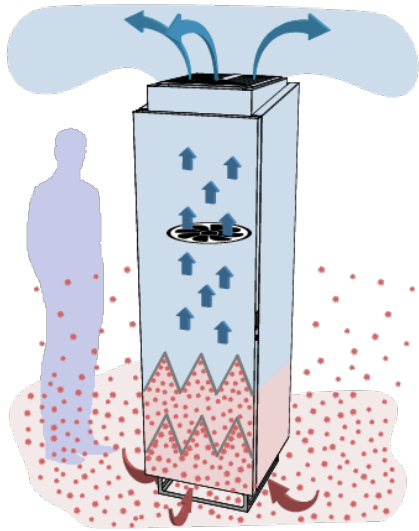

Schematic illustration

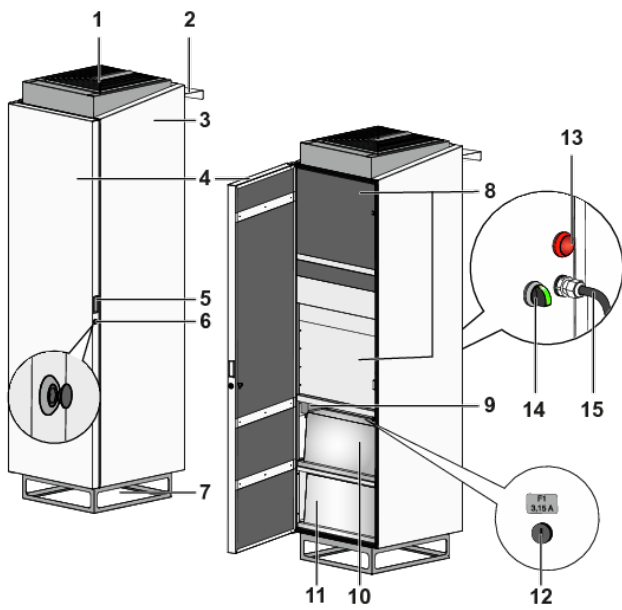

- 1 Air discharge
- 2 Fixing brackets
- 3 Casing
- 4 Door
- 5 Flush pull handle
- 6 Door lock
- 7 Air inlet
- 8 Fan sound attenuator unit
- 9 Controller
- 10 Main filter

11 Prefilter

12 Micro fuse

13 Filter change alert (red)

14 Mains isolator with indicator light (green)

15 Mains connection cable

Construction	L	M
Filter dimensions	592 x 592 x 292 mm	592 x 287 x 292 mm
Filter classes	ePM1 85 %/H13	ePM1 85 %/H13
Weight with/without packaging	217 kg/177 kg	158 kg/137 kg
Nominal voltage	230 V AC	230 V AC
Nominal voltage range	200 – 277 V AC	200 – 277 V AC
Frequency	50/60 Hz	50/60 Hz
Nominal current	2.3 A	2.3 A
Mains fuse	16 A	16 A
Micro fuse F1	3.15 A	3.15 A
IEC protection class	I (protective earth)	I (protective earth)
Ambient temperature	+5 °C to +45 °C	+5 °C to +45 °C
Humidity	≤ 90% relative humidity, no condensation	≤ 90% relative humidity, no condensation

TAP-L Variants

Low-noise, even at high air change rates

Volume flow rate	Sound power level of the device	Sound pressure level in the application area	Power consumption
m ³ /h	dB(A)	dB(A)	W
400	32	24	20
600	40	32	30
800	45	37	55
1000	49	41	95
1200	53	45	150
1400	58	50	225
1600	61	53	310

TAP-M Variants

Low-noise, even at high air change rates

Volume flow rate	Sound power level of the device	Sound pressure level in the application area	Power consumption
m ³ /h	dB(A)	dB(A)	W
400	38	30	37
500	42	34	56
600	45	37	82
700	48	40	115
800	51	43	155
1000	56	48	256
1200	60	52	386

TAP-L Variants



TAP-M Variants



Specification text

- Available in 2 unit sizes
 - Size L, maximum volume flow rate q_v : 1600 m³/h
 - Size M, maximum volume flow rate q_v : 1200 m³/h
- Air purification unit as floor-mounted unit for classrooms and administrative rooms in schools; functional unit wired ready for plugging in
- Double sound-insulated metal housing with sound-absorbing inner coating
- Vandal-proof due to extremely stable, solid casing
- Tamper-proof due to arrangement of the control on the inside of the unit; door can only be opened with a key
- Supply air and extract air cone silencer (patented)
- EC fan system, air output adjustable in power levels
- Air intake at the bottom, air discharge at the top with a ventilation grille, with fixed fins for directionally oriented horizontal air intake into the room at a height of 2.30 m. The clean air output is targeted above head height in 3 directions. This means the unit can work with high ventilation performance, without the formation of draughts. It also prevents viruses being distributed directly with the air being discharged in the room.
- Double-layer filter system with prefilter (ePM1) and HEPA-13 filter with a minimum filtration efficiency of 99.95%; filter life of the HEPA filter approx. 2 years (VDI 6022)
- Wall fixing for accident prevention
- Rear ON/OFF switch can be operated from the outside
- Micro fuse with 3.15 A can be operated from the outside
- Filter change alert with LED can be seen on the outside of the unit
- With filter monitoring
- With regulating unit controlled by volume flow rate:
 - Unit always keeps the selected volume flow rate constant – even with increased air resistance of the fan
 - This ensures that the indoor air is cleaned to the full extent even if the filters become increasingly contaminated

Controller display

Steplessly adjustable

- Size L: 400 – 1600 m³/h
- Size M: 400 – 1200 m³/h

Display (size L, M)

- Volume flow rate actual value (air change rate) [m³/h]
- Volume flow rate setpoint value (air change rate) [m³/h]
- Maximum controllable volume flow rate [m³/h]
- Actual value of the output voltage for fan [V]
- Actual value of the differential pressure Δ_p [Pa]

Prefilter

Size L, M

Filter class: ePM1 85%; Mini Pleat filter insert type MFI for the separation of fine dust and suspended particles such as aerosols, toxic dusts, viruses and bacteria from the supply and extract air in ventilation systems. Certified by Eurovent as fine dust filter. Hygienically compliant according to VDI 6022; ePM1 filter class: classification according to ISO 16890; efficiency: 85%; PLA version: frame made of plastic.

Prefilter characteristics

Size L

- Filter class ePM1 : 85%
- Volume flow rate q_v : 1600 m³/h
- Initial differential pressure Δ_{pi} : 36 Pa
- Filter breadth B: 592 mm
- Filter height H: 592 mm
- Filter depth D: 292 mm
- Filter area A_{fm} : 16.8 m²
- Nominal volume flow rate $q_{v,nom}$: 4250 m³/h

Size M

- Filter class: ePM1 85%
- Volume flow rate q_v : 1200 m³/h
- Initial differential pressure Δ_{pi} : 62 Pa
- Filter breadth B: 592 mm
- Filter height H: 287 mm
- Filter depth D: 292 mm
- Filter area A_{fm} : 7.7 m²
- Nominal volume flow rate $q_{v,nom}$: 2125 m³/h

Main filter

Size L, M

Filter class: HEPA H13; Mini Pleat filter insert type MFI for the separation of fine dust and suspended particles such as aerosols, toxic dusts, viruses and bacteria from the supply and extract air in ventilation systems. Use of final filter as particulate filter for the most critical requirements of air cleanliness and sterility in areas such as production, research, medicine, pharmaceuticals industry, and nuclear engineering. Optimum pleat position and largest possible filter area allow low initial differential pressures. Mini Pleat filter insert as fine dust filters are certified according to Eurovent. Mini Pleat filter inserts MFI are hygienically compliant to VDI 6022. GAL version: galvanised steel frame.

Main filter features

Size L

- Filter class H13, particulate filter to EN 1822
- Volume flow rate q_v : 1600 m³/h
- Initial differential pressure Δ_{pi} : 123 Pa
- Filter breadth B: 592 mm
- Filter height H: 592 mm
- Filter depth D: 292 mm
- Filter area A_{fm} : 30.6 m²
- Nominal volume flow rate $q_{v,nom}$: 3000 m³/h
- Number of filter packs: 8
- With protection grid on the downstream side
- With test: oil mist test

Size M

- Filter class H13, particulate filter to EN 1822

- Volume flow rate q_v : 1600 m³/h
- Initial differential pressure Δp_i : 200 Pa
- Filter breadth B: 592 mm
- Filter height H: 287 mm
- Filter depth D: 292 mm
- Filter area A_{fm} : 13.6 m²
- Nominal volume flow rate $q_{v, nom}$: 1500 m³/h
- Number of filter packs: 8
- With protection grid on the downstream side
- With test: oil mist test

Fan

Subassembly L, M

- Nominal voltage: 230 V
- Nominal voltage range: 0 – 277 VAC
- Frequency: 50/60 Hz
- Nominal current: 2.3 A
- Mains fuse: 16 A
- Micro fuse: 3.15 A
- IEC protection class: I protective conductor
- Ambient temperature: 5 – 45 °C
- Ambient air pressure: 800 – 1050 mbar
- Humidity: ≤ 100%, no condensation

Acoustic data

According to VDI 2081: recommendation for schoolrooms and classrooms at max. 35 dB(A)

Size L

- Sound pressure level in the room 35 dB(A) at 750 m³/h and power 44 W
- Sound pressure level in the room 45 dB(A) at 1200 m³/h and power 150 W
- Sound pressure level in the room 53 dB(A) at 1600 m³/h and power 310 W
- Room attenuation 8 dB taken into account

Size M

- Sound pressure level in the room 35 dB(A) at 550 m³/h and power 69 W
- Sound pressure level in the room 52 dB(A) at 1200 m³/h and power 386 W
- Room attenuation 8 dB taken into account

Dimensions and weight

Size L

- Weight with/without packaging: 177/217 kg
- Unit dimensions (B × H × D): 644 × 2313 × 701 mm

Size M

- Weight with/without packaging: 137/175 kg
- Unit dimensions (B × H × D): 644 × 2313 × 441 mm

TAP	-	SPC	-	L	/	P1-RAL...	/	P2-RAL...	/	400 – 1600 [m³/h]
1		2		3		4		5		6

1 Type
TAP TROX AIR PURIFIERS

2 Casing material
SPC galvanised sheet steel, powder-coated

3 Dimensions
L Floor-mounted unit B × H × D 644 × 2313 × 701 mm
M Floor-mounted unit B × H × D 644 × 2313 × 441 mm

4 Body surface
No entry required: powder-coated, colour RAL 9016 20 %
P1 powder-coated, colour RAL 7012 20 %

5 Diffuser surface/base frame
No entry required: powder-coated, colour RAL 7012 20 %
P2 powder-coated, colour RAL 7021 20 %

6 Operating values for factory setting
400 – 1600 m³/h applicable for dimension L
400 – 1200 m³/h applicable for dimension M

TAP-SPC-L/1600

Casing material	galvanised sheet steel, powder-coated
Dimensions	644 × 2313 × 701 mm
Surface (body)	Standard finish 9016-GE20
Colour P1 (body)	RAL 9016
Gloss level (body)	GE 20
Surface (diffuser/base)	Standard finish 7012-GE20
Colour P1 (diffuser/base)	RAL 7012
Gloss level (diffuser/base)	GE 20
Volume flow rate	1600 m³/h

Variants, Product details, Replacement filters



TAP-L Variant



TAP-L with body RAL 9016
TAP-L Variants



TAP-L with body RAL 7012

Dimensions and space required

TAP-L

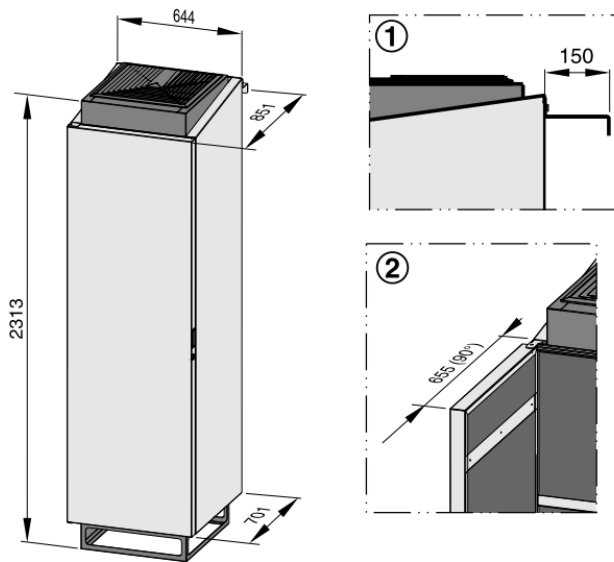

- 1 Door opening dimension (hinge left)
- 2 Fixing brackets (wall distance)

TAP-M

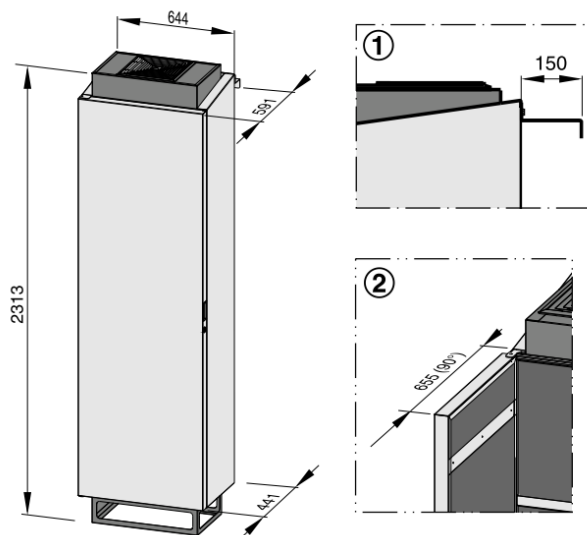

- 1 Door opening dimension (hinge left)
- 2 Fixing brackets (wall distance)

Space required

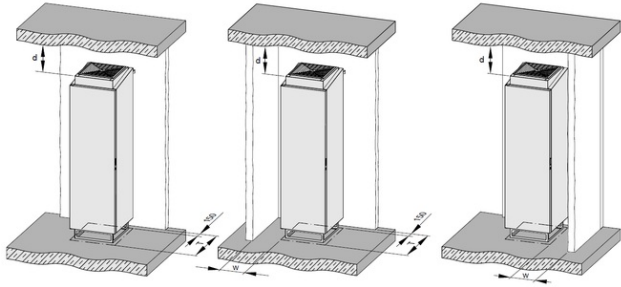

Distance from ceiling (d) = at least 100 - 200 mm
Distance from side wall (w) = 1 - 3 mm
T = TAP-L: 851 mm; TAP-M: 591 mm

The distances depend on the airflow set on the air purifier. With regard to space requirements, it must be ensured that the control elements on the rear of the unit remain accessible and that the door can be opened far enough to allow a filter change (door opening angle 90°).

**SIZE L
PREFILTER**

- Type: MFI-ePM1-85%-PLA/592x592x292x6 (see specification text)
- Filter class: ePM1 85%

Main filter

- Type: MFI-H13-GAL/592x592x292x8 (see specification text)
- Filter class: HEPA H13

Size M

Prefilter

- Type: MFI-ePM1-85%-PLA/592x287x292x6 (see specification text)
- Filter class: ePM1 85%

Main filter

- Type: MFI-H13-GAL-592x287x292x8 (see specification text)
- Filter class: HEPA H13

More information about replacement filters can be found on our [website](#) and in our [product data sheet](#).

Produktdatenblatt
MFI



Mini Pleat Filtereinheit
Serie SIF



Mini Pleat Filtereinheit
Serie MFI, Ausführung
SPC



Mini Pleat Filter

MFI



Eurovent-Zertifizierung

Für große Volumenströme in kompakter Bauform



Geprüft nach VDI 6022



ATEX-Ausführung optional

Vor- oder Endfilter zur Abscheidung von Feinstaub und Schwebstofffilter für höchste Anforderungen in raumlufttechnischen Anlagen

- Filtergruppen ISO ePM10, ISO ePM1 (Feinstaubfilter) und EPA, HEPA (Schwebstofffilter)
- Leistungsdaten geprüft nach ISO 16890 oder nach EN 1822-1 und ISO 29463-2 bis ISO 29463-5
- Eurovent-Zertifizierung für Feinstaubfilter
- Hygienekonform nach VDI 6022
- Hohe Energieeffizienz gemäß Eurovent
- Optimierte Energieeffizienz der Ausführung PLA-ECO in ISO ePM1
- Auf spezielle Anforderungen abgestimmte Filtermedien aus Glasfaserpapieren mit Abstandhaltern aus thermoplastischem Schmelzkleber oder Textilläden
- Geringe Anfangs-Druckdifferenz durch optimale Faltenstellung und größtmögliche Filterfläche
- Kompakte V-Bauform mit geringen Einbaulängen
- Einbaumöglichkeiten in Standard-Zellenrahmen für Filterwände (Serie SIF), in Aufnahmerahmen (Serie MF) oder in Universalgehäuse (Serie UCA) für Kanaleinbau

Optionale Ausstattung

- ATEX-Ausführung für Schutzzonen 1 und 2 sowie 21 und 22

1
PD-12/2019 - DE/de

TROX España



Ctra. Castellón, Km. 7
Pol. Ind. La Cartuja
E-50720 Zaragoza
Tel: +34 976 50 02 50
Fax + 34 976 50 09 04
Email: trox@trox.es

Servicios myTROX

- › [Contactos](#)

- › [Formulario de contacto](#)

- › [Mapa de situación](#)

- › [Condiciones de venta y garantía](#)

- › [TROX Plazos de entrega](#)

- › [Certificado AENOR](#)

- › [Certificado IQNet](#)

- › [Certificado TÜV](#)

Contacto telefónico:

Delegaciones comerciales
[Contacto](#)

Customer Service
+34 976 50 02 50

Horario de atención al cliente: de Lunes a
Jueves de 9:00 a 14:00 y de 15:30 a 17:30 ·
Viernes de 9:00 a 14:00 h

TROX EN REDES SOCIALES
