



LOCATION	AKG INTERNATIONAL	TELEPHONE	FAX
AKG Fellow Subsidiaries (Germany)			
Hofgeismar	Autokühler GmbH & Co. KG	(49) 5 67 1-88 3-0	(49) 5 67 1-35 82
Hofgeismar	AKG Thermotechnik GmbH & Co. KG	(49) 5 67 1-88 3-0	(49) 5 67 1-31 98
Dortmund	AKG Thermotechnik GmbH & Co. KG	(49) 2 31-218 431	(49) 2 31-21 11 97
Appenweier	Autokühler GmbH & Co. KG	(49) 7 80 5-49 8-0	(49) 7 80 5-498-10
Uslar	AKG Thermotechnik GmbH & Co. KG	(49) 5 57 1-92 46-0	(49) 5 57 1-92 46-19
Oberbobritzsch	Autokühler GmbH & Co. KG		
	Vertriebsbüro Freiberg	(49) 3 73 25-75 53	(49) 3 73 25-75 53
AKG Fellow Subsidiaries (International)			
France	AKG France Sarl	(33) 3 87 95 11 11	(33) 3 87 95 50 05
Great Britain	AKG UK Limited	(44) 14 43-67 80 50	(44) 14 43-67 37 73
Turkey	AKG-SRF Endüstriyel	(90) 2 32-26 55 169	(90) 2 32-26 55-170
China	AKG (Shanghai) Co., Ltd.	(86) 21 58 66 12 53	(86) 21 58 66 12 54
Singapore	AKG Trading	(65) 96 26 36 17	(65) 362 22 63
USA	AKG of America, Inc.	(1) 919-563-42 86	(1) 919-563-60 60
USA	AKG Thermal Systems, Inc.	(1) 919-563-48 71	(1) 919-563-49 17
AKG Authorized Dealers (Germany)			
Bad Waldsee	Nold GmbH	(49) 7 52 4-97 20 0	(49) 7 52 4-97 20 70
Deggendorf	Pregler GmbH & Co. KG	(49) 9 91-250 550	(49) 9 9 1-25 05 29
Ludwigsburg	SLB GmbH Industriekühler	(49) 7 14 1-290 902	(49) 7 14 1-29 09 05
Mönchengladbach	Michael Widler Filtration und Kühlung	(49) 2 16 1-96 02 87	(49) 2 16 1-96 02 89
Mühlhausen	Kämmer & Druselmann Antriebs- und Steuerungstechnik	(49) 3 60 1-44 40 13	(49) 3 60 1-444 014
Neubrandenburg	Lippold Hydraulik & Wälzlager GmbH	(49) 3 95-36 302-20	(49) 3 95-36 30 2-29
Neust./Speyersdorf	Hydraulik Technik Hauck	(49) 6 32 7-98 20	(49) 6 32 7-13 60
Oberweser-Gottstreu	Hega Antriebstechnik	(49) 5 57 4-18 42	(49) 5 57 4-418
Waidhofen	Tyroller Hydraulik GmbH	(49) 8 44 3-92 66 0	(49) 8 44 3-92 66 33
AKG Sales Representatives (Europe)			
Finland	Nestepaine	(358) 9-61 36 33	(358) 9-61 36 36 66
France	GEA Ergé-Spirale et Soramat S. A.	(33) 3 21 69 89 00	(33) 3 21 69 89 74
France	Guiomard S. A. R. L.	(33) 13 42 15 0 44	(33) 13 42 15 2 14
Italy	Cantalupo	(39) 02 939 00 326	(39) 02 939 00 327
Poland	IOW Polska	(48) 76 85 22 117	(48) 76 85 22 119
Sweden	AB Pegol	(46) 31-24 74 10	(46) 31-12 77 96
Switzerland	Autokühler AG, Switzerland	(41) 1 840 65 00	(41) 1 840 60 80
Slovenia	Agis-Klima d. o. o.	(386) 62 77 14 64	(386) 62 77 24 72
Spain	Imprefil	(34) 91 80 3 11 19	(34) 91 80 3 47 56
AKG Sales Representatives (World)			
Australia	Fluid Dynamics	(61) 3 97 96 59 88	(61) 3 97 96 57 77
Brazil	Apema	(55) 11 756 25 77	(55) 11 756 60 97
India	Alkraft	(91) 44 625 87 90	(91) 44 625 87 70
Malaysia	Alra Radiator	(603) 836 81 00	(603) 836 80 77
Mexico	Linning de Mexico	(52) 5 556 87 11	(52) 555 68 725
South Korea	Global	(82) 32 87 20 401	(82) 32 87 20 403
USA	WORLD PAC	(1)-510 742 89 00	(1)-510 742 19 93

AKG – A World Class Supplier

The AKG group is one of the biggest suppliers of aluminium heat exchangers for industrial use world-wide.

Coolers and cooling systems for various applications are manufactured in Germany and at many international production sites.

Hydraulic Coolers – Made by AKG



Autokühler GmbH & Co. KG
 Postfach 1346
 D-34363 Hofgeismar
 telephone (49) 56 71 / 8 83-0
 fax (49) 56 71 / 35 82
 Internet: <http://www.akg-gruppe.de>
 E-Mail: Info@akg-gruppe.de

AKG - edition 1999-1-E (changes and errors excepted)



Technical Specification





Oil/Air- Cooling Systems

AKG-Range
T1 - T11

Features

- High efficiency cooling systems made from Aluminium
- High performance and working pressure - even for heavy duty hydraulic and lubrication applications
- Maximum working pressure
T1 -T8 26 bar
T9 -T11 10 bar
- Offering high flexibility for usage with transmission, engine, hydraulic and lubrication oils
May be also used as off-line coolers
- Cooling systems can be fitted with 12V/24V DC, 3 phase or hydraulic motors

Benefits

- Short lead times
- Cost effective
- Cooling systems fully equipped for immediate use
- Spares from stock
- Robust design, tried and tested for many years
- Maintenance free
- Low noise levels

Applications

The units can be used for cooling: mineral oil, synthetic oil, bio oil, HFA B C D liquids, water/glycol mixture, containing 50% antifreeze and corrosion inhibitors

Function: Heat will be transferred from the fluid to the cooling air flow

Options

- Temperature regulator
- Off-line cooler packages with integral pump
- 60 Hz electric motors
- Pusher fans (standard equipment is puller fans)

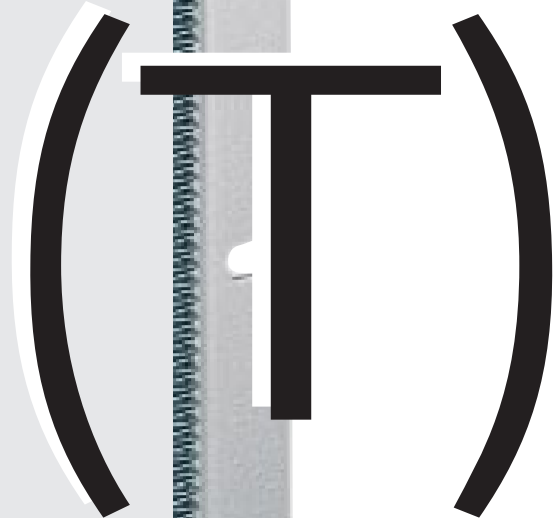

General

Our T range is designed to help you find an individual solution for your cooling application.

Our cooling systems offer a wide variety of products which have been fully tried and tested even under the most arduous working conditions.

A range of 11 basic types covers almost all cooling applications involving a large variety of fluids in stationary and mobile machines.

AKG and its representatives as experts in the field of cooling systems will be delighted to assist you.

As part of our ongoing technical improvements, AKG maintains the right to introduce modifications to the specifications in this brochure.

Please note:

- Set up and operating instructions
- General Terms of Sales and Delivery
- Spares list

Technical Data

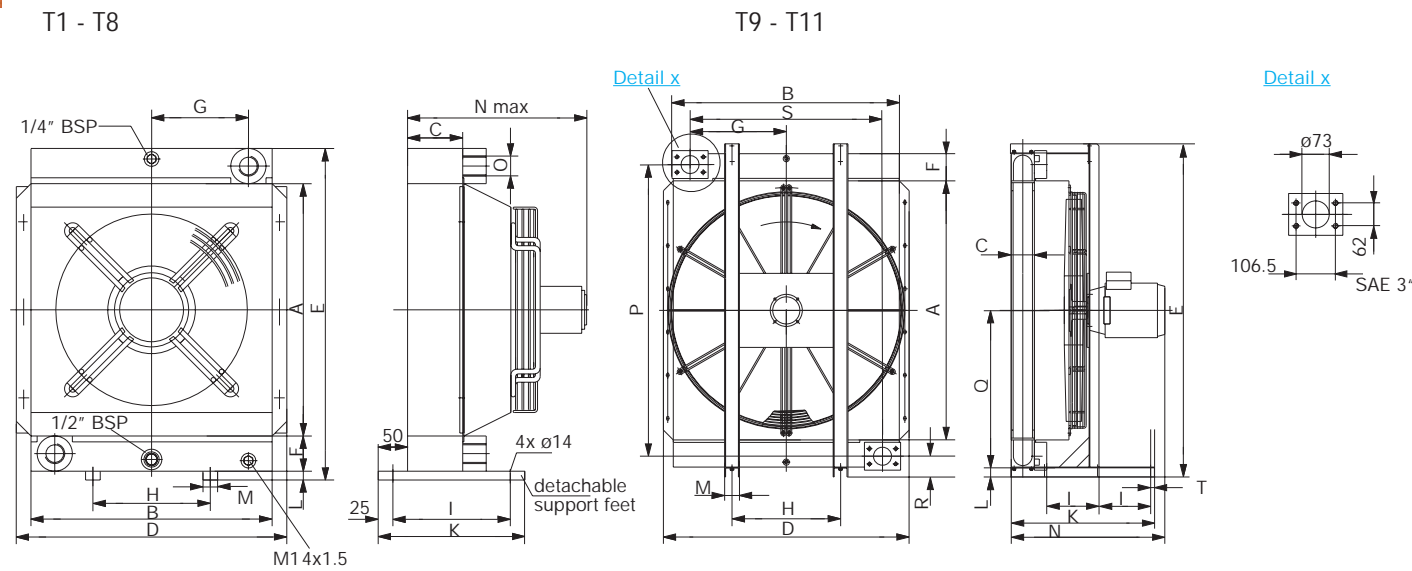

SPECIFICATION											
Cooler Type	T1	T2	T3	T4	T5 (T5K) ²⁾	T6	T7	T8	T9	T10	T11
Heat rejection ¹⁾	1-5	3-10	8-15	10-20	15-25	20-35	25-40	35-75	60-120	85-180	120-260
DIMENSIONS											
A	200	300	400	400	550	650	800	800	1050	1200	
B	191	302	396	396	411	557	557	651	915	1206	
C	63	63	63	94	94 (63)	94	94	140	94	113	140
D	248	355	451	451	466	607	608	722	995	1276	
E	315	415	515	535	690	790	940	960	1352	1520	
F	50	50	50	60	60	60	60	70	110	110	
G	65	115	160	160	165	235	235	280	390	532	
H	80	150	200	200	200	310	310	400	440	525	
I	150	200	200	250	250	250	250	250	215	210	
K	200	250	250	300	300	300	300	300	580	750	
L	15	15	15	15	20	20	20	20	40	50	
M	25	25	25	25	30	50	50	50	65	100	
N max.	175	370	400	430	440 (410)	ca. 450	ca. 450	ca. 590	ca. 650	ca. 790	ca. 900
O	1\"BSP	1\"BSP	1\"BSP	1 1/4\"BSP	1 1/4\"BSP (1\"BSP)	1 1/4\"BSP	1 1/4\"BSP	1 1/2\"BSP			
P									1182	1332	
Q									635	710	
R									91	94	
S									780	1064	
T									15	20	

all dimensions in [mm]

ORDER CODE SYSTEM

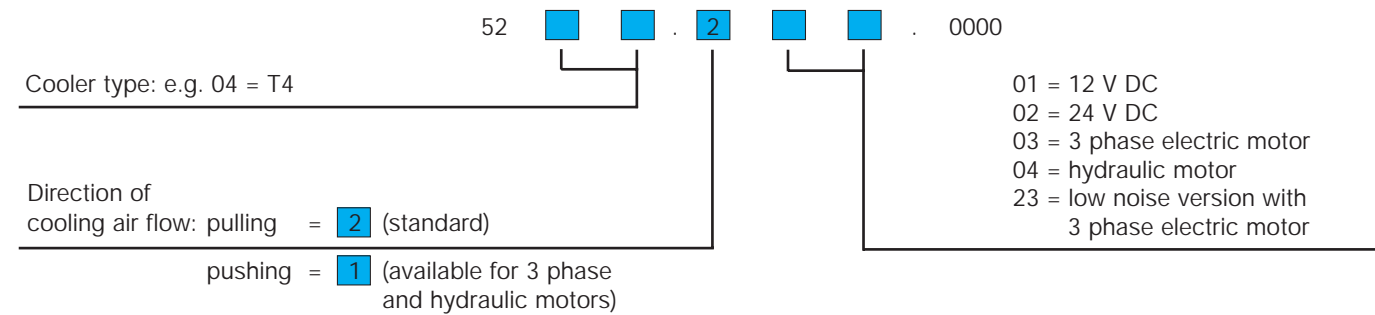

1) For details use diagrams and tables as appropriate
 2) use T5K for low oil flows
 All systems are pressure tested according to DIN 50104

Cooler Type	Order Number	Fan Diameter [mm]	Fan Speed [rpm]	Noise Level [dB(A), 1m]	Motor Voltage [V]	Power Consumption [kW]	Volume [l]	Working Pressure [bar]	Total Weight excluding fluid [kg]
T1	5200.201.0000	167	3250	71	12	0.08	1.0	26	6,7
	5200.202.0000	167	3250	71	24	0.08	1.0	26	6,7
T2	5202.201.0000	255	2600	74	12	0.15	1.9	26	15.6
	5202.202.0000	255	2600	72	24	0.15	1.9	26	15.6
	5202.203.0000	250	3000	75	230/400	0.25	1.9	26	15.6
	5202.204.0000	250	3000	75	Hydraulic		1.9	26	15.6
L	5202.223.0000	250	1500	57	230/400	0.18	1.9	26	15.6
T3	5203.201.0000	350	2950	76	12	0.2	2.9	26	23
	5203.202.0000	350	2950	78	24	0.25	2.9	26	23
	5203.203.0000	380	1500	75	230/400	0.37	2.9	26	23
	5203.204.0000	380	1500	75	Hydraulic		2.9	26	23
	5203.223.0000	380	1000	68	230/400	0.25	2.9	26	23
T4	5204.201.0000	350	2950	77	12	0.2	5.2	26	28.8
	5204.202.0000	350	2950	78	24	0.25	5.2	26	28.8
	5204.203.0000	380	1500	77	230/400	0.37	5.2	26	28.8
	5204.204.0000	380	1500	77	Hydraulic		5.2	26	28.8
	5204.223.0000	380	1000	68	230/400	0.25	5.2	26	28.8
T5	5205.201.0000	385	3100	79	12	0.27	6.3	26	38
	5205.202.0000	385	3100	79	24	0.24	6.3	26	38
	5205.203.0000	450	1500	77	230/400	0.37	6.3	26	38
	5205.204.0000	450	1500	77	Hydraulic		6.3	26	38
	5205.223.0000	450	1000	68	230/400	0.25	6.3	26	38
K	5215.203.0000	450	1500	77	230/400	0.37	6.3	26	38
T6	5206.203.0000	500	1500	79	230/400	0.55	9.4	26	49
	5206.204.0000	500	1500	79	Hydraulic		9.4	26	49
	5206.223.0000	500	1000	68	230/400	0.37	9.4	26	49
T7	5207.203.0000	500	1500	79	230/400	0.55	10.6	26	54
	5207.204.0000	500	1500	79	Hydraulic		10.6	26	54
	5207.223.0000	500	1000	68	230/400	0.37	10.6	26	54
T8	5208.203.0000	630	1000	79	230/400	1.1	17.7	26	89
	5208.204.0000	630	1000	79	Hydraulic		17.7	26	89
	5208.223.0000	630	750	68	230/400	0.55	17.7	26	89
S	5208.231.0000	630	1000	90	230/400	2.2	17.7	26	89
T9	5209.203.0000	900	1000	88	230/400	2.2	25	10	190
	5209.204.0000	900	1000	88	Hydraulic		25	10	190
	5209.223.0000	900	750	82	230/400	1.5	25	10	190
T10	5210.203.0000	900	1500	98	400/690	5.5	31	10	200
	5210.204.0000	900	1500	98	Hydraulic		31	10	200
	5210.223.0000	900	1000	88	230/400	3.0	31	10	200
T11	5211.203.0000	1000	1500	100	400/690	11.0	55	10	ca. 290
	5211.223.0000	1000	1000	90	400/690	7.5	55	10	ca. 290

3 phase electric motor: T2 - T9 B14, small flange
 displacement [cm³] hydraulic motor: T10 - T11 B5
 T2 - T8 11 ccm
 T9 - T10 21 ccm

Materials

Cooler: Aluminium
 Fan blade: Plastic
 Fan cowl, finger guard, support feet, motor support flange: Zinc plated, painted / Powder coated steel

Easy sizing of T-coolers

The following tables may be used to quickly select a T-cooler.
 The data is based on the assumption that oil inlet temperature does not exceed 70 °C for hydraulic and 110 °C for lubrication applications.

Please use the following heat rejection figures if no details are available:

- Agricultural and construction machinery: 1/3 of Diesel engine power
- Hydraulic pumps driven by an electric motor: 1/3 of electric motor power

Hydraulic applications

Heat rejection [kW @ 30 °C ambient temperature]													
Oil flow in l/min	T1	T2	T3	T4	T5K	T5	T6	T7	T8	T8S	T9	T10	T11
10	2	4	6										
20	3	6	8	11	15								
30	4	7	10	13	17								
50	5	8	12	15	18	21	28	32	39	46			
75	5.5	9	13	17	20	23	30	34	42	52	80		
100		10	14	18	21	24	31	36	44	56	86	112	
150			16	19	23	26	34	38	48	63	93	128	167
200						28	35	40	50	68	100	140	180
250									51	72	108	148	193
300											112	156	208
400											120	168	228
500												180	248
600													264

Heat rejection [kW @ 40 °C ambient temperature]													
Oil flow in l/min	T1	T2	T3	T4	T5K	T5	T6	T7	T8	T8S	T9	T10	T11
10	1.5	3	5										
20	2.5	4	6	8	11								
30	3	5	7	10	13								
50	3.5	6	9	11	14	16	21	24	29	35			
75		4	7	10	12	15	17	22	26	31	39	60	
100		8	11	13	16	18	23	27	33	42	65	84	
150			12	14	17	20	25	29	36	47	70	96	125
200						21	26	30	37	51	75	105	135
250									38	54	81	111	145
300											84	117	156
400											90	126	171
500												135	186
600													198

Easy sizing of T-coolers

For a more detailed and customised cooler selection exact temperatures and flows are necessary.
 Please select your cooler according to the example on page 10 or seek advice from AKG or its representatives.

Lubrication oil applications

Heat rejection [kW @ 30 °C ambient temperature]													
Oil flow in l/min	T1	T2	T3	T4	T5K	T5	T6	T7	T8	T8S	T9	T10	T11
10	4	8	12										
20	6.5	11	16	22	30								
30	8	14	19	26	34	35							
50	9.5	17	23	30	37	42	55	64	78	93			
75	10.5	19	26	34	40	46	60	69	83	104	160		
100		21	28	35	42	49	62	72	88	112	172	224	
150			32	38	46	53	67	77	96	126	187	256	330
200						56	70	80	100	136	200	280	360
250									102	144	216	296	387
300											224	312	416
400											240	336	456
500												360	496
600													528

Heat rejection [kW @ 40 °C ambient temperature]													
Oil flow in l/min	T1	T2	T3	T4	T5K	T5	T6	T7	T8	T8S	T9	T10	T11
10	3.5	7	11										
20	5.5	10	14	20	27								
30	7	12	17	22	30								
50	8	14	20	27	32	37	48	56	69	81			
75	9	16	22	29	35	40	53	60	73	91	140		
100		18	24	31	37	43	55	63	77	98	150	196	
150			28	33	40	46	59	67	84	110	163	224	292
200						49	62	70	88	119	175	245	315
250									90	126	189	259	338
300											196	273	364
400											210	294	399
500												315	434
600													462

Specific heat rejection T1 - T8

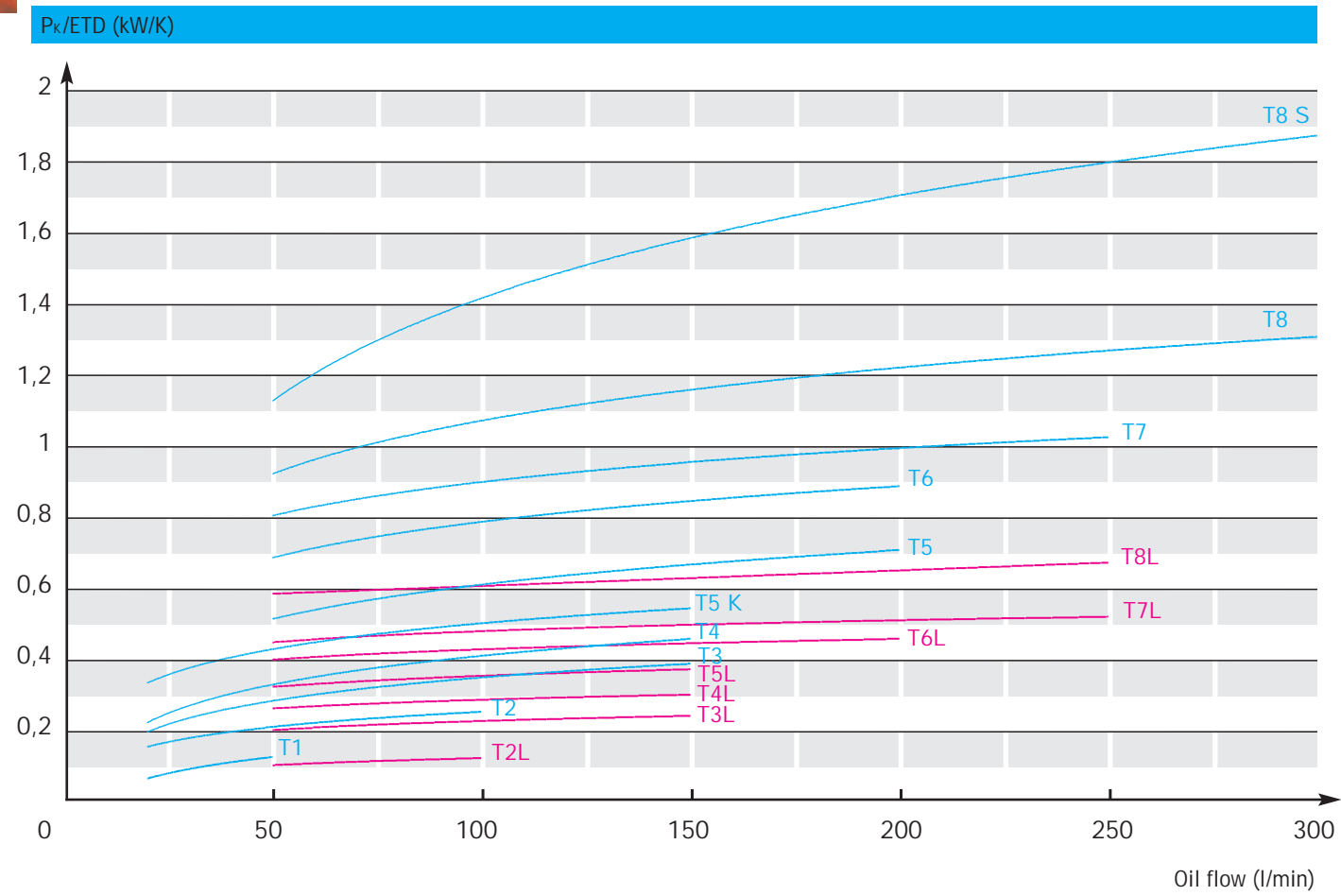

Specific heat rejection T9 - T11

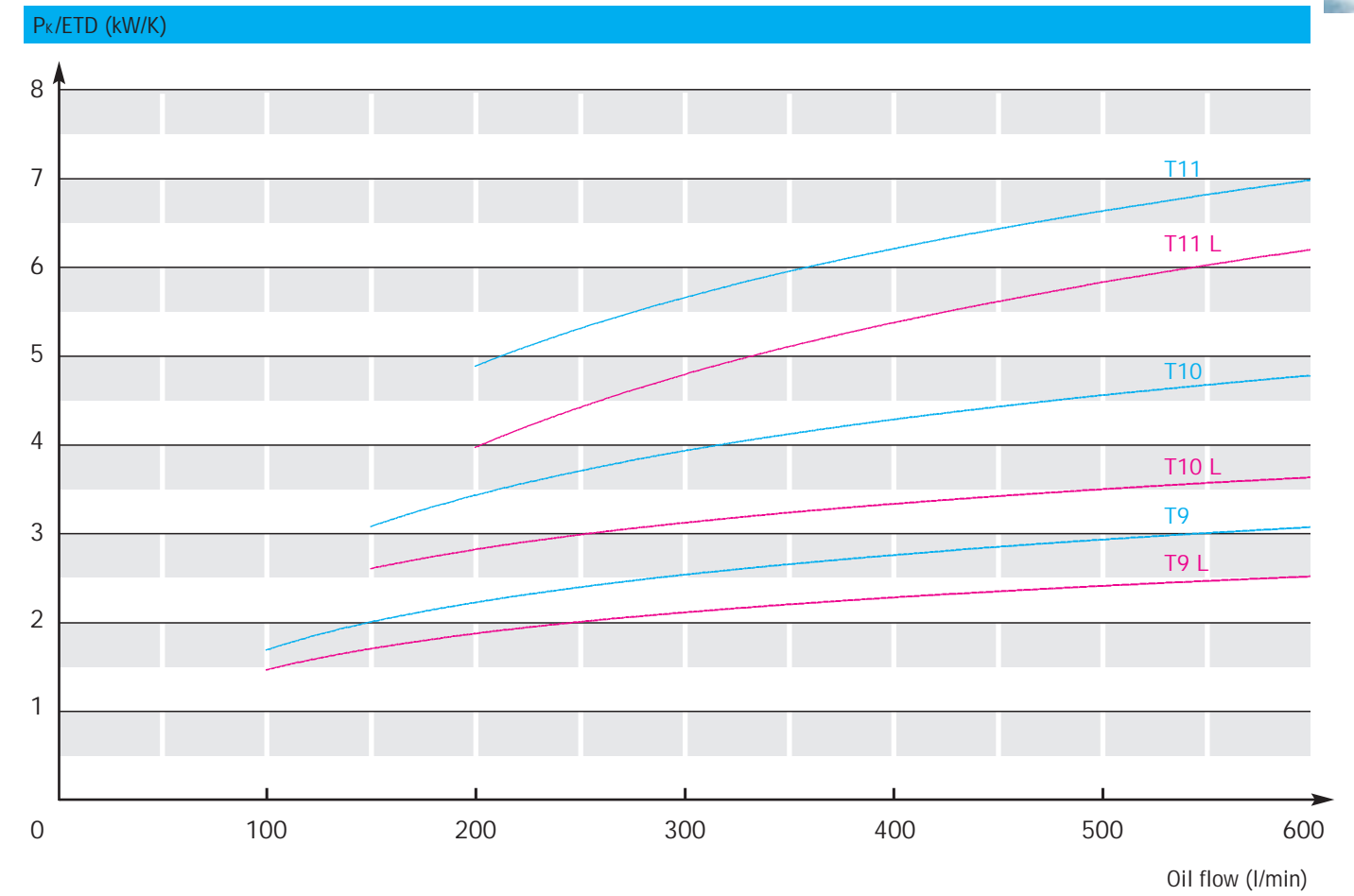

Pressure drop T1 - T8

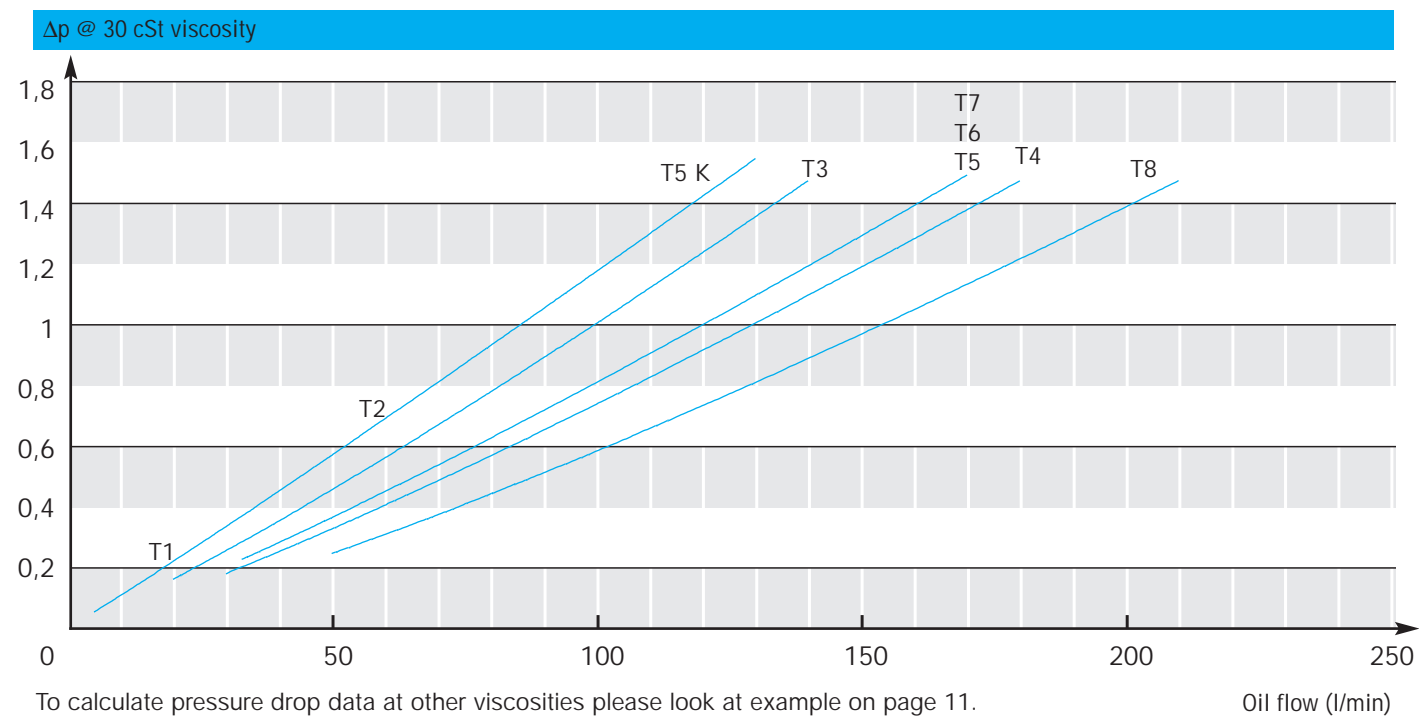

To calculate pressure drop data at other viscosities please look at example on page 11.

Pressure drop T9 - T11

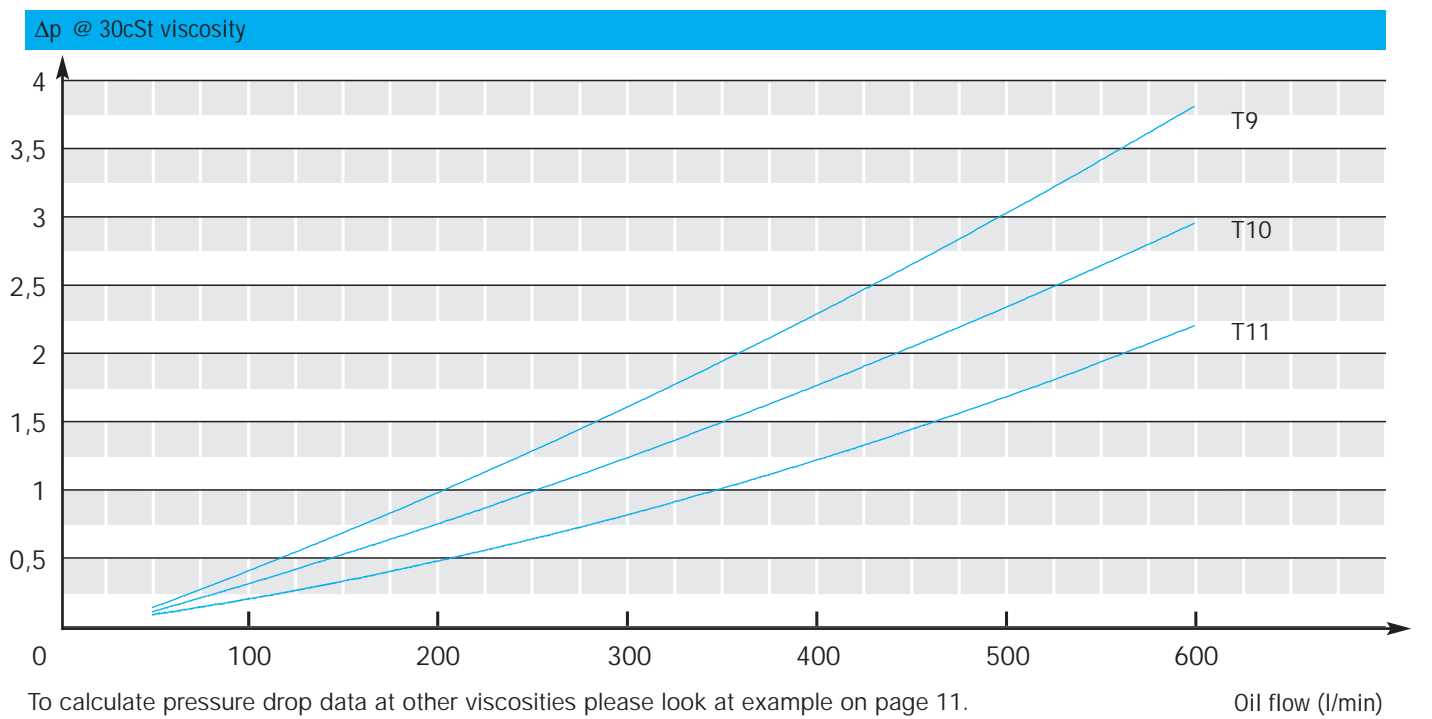

To calculate pressure drop data at other viscosities please look at example on page 11.

Selecting a cooling system

To select a cooler for your application, the following data is required:

- Heat rejection: Alternative terminology is dissipation
- Oil flow: Circulating oil flow determines the cooler size
- Oil inlet temperature: Temperature of the oil entering the cooler
- Cooling air flow temperature: Air temperature at cooler face before entering matrix

1. Determination of input data

P_{req} [kW] Heat rejection
 V_{oil} [l/min] Oil flow
 T_{oil} [°C] Oil inlet temperature
 T_{caf} [°C] Cooling air flow temperature

Example

$P_{req} = 12$ kW
 $V_{oil} = 50$ l/min
 $T_{oil} = 70$ °C
 $T_{caf} = 30$ °C

2. Specific heat rejection

ETD [K] = $T_{oil} - T_{caf}$ Entering Temperature Difference
 P_{shr} [kW/K] = P_{req} / ETD required specific heat rejection

ETD [K] = $T_{oil} - T_{caf} \Rightarrow 70$ °C - 30 °C = 40 °C (= 40 K)
 $P_{shr} = P_{req} / ETD \Rightarrow 12$ kW / 40 K = 0.3 kW/K

3. Select according to diagram

P_{shr} / ETD [kW/K] actual specific heat rejection
 $P = (P_{shr} / ETD) \times ETD$ actual heat rejection

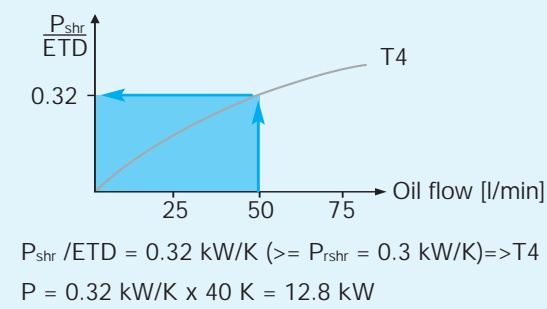

4. Pressure drop / Oil temperature difference

Obtain pressure drop @ 30 cSt oil viscosity from diagram on page 8. To calculate for other oil viscosities please use example on page 11.
 ΔT_{oil} [°C] = $33 \times P$ [kW] / V_{oil} [l/min]

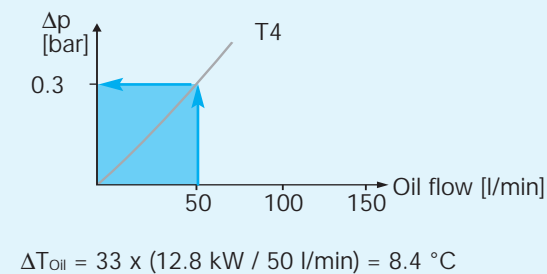

5. Results

selected cooler T4: heat rejection 12.8 kW,
 oil temperature difference 8.4 °C,
 pressure drop 0.3 bar

Conversion factors for different oil pressure drops

The pressure drop curves on pages 8 and 9 are based on a viscosity of 30 mm²/s = 30 cSt. Please use conversion factor f to calculate pressure drop at other viscosities.

$\frac{\text{mm}^2}{\text{s}}, \text{cSt}$	10	15	20	30	40	50	60	80	100
f	0.5	0.65	0.75	1.0	1.2	1.4	1.6	2.1	2.8

Example:

Pressure drop of type T7 is 1.3 bar @ 150 l/min and 30 mm²/s.
 Assume an oil type ISO VG 46 is used @ 60 °C having a viscosity of 20 mm²/s.
 To calculate new pressure drop multiply 1.3 bar by f = 0.75 to obtain the actual pressure drop 1 bar approximately.

Notes: