



DECORATION







Columns
Page 2



Indirect Lighting
Page 25



Cornices
Pages 40 - 41



Domes and Niches
Pages 50 - 51



Fireplaces
Page 3



Corbels
Pages 26 - 31



Decorative Mouldings
Page 42



Sculptures
Pages 52 - 53



Bookcases
Pages 4 - 8



Ceiling Roses
Pages 32 - 35



Friezes
Page 43



Tradicional Ceiling Tiles
Page 54



Arches
Pages 9 - 22



Medallion
Page 35



Mouldings
Pages 44 - 45



Club Emblems
Page 54



**Multiple Steps
Cornices**
Page 23



Wall Lamps
Page 36



**Wall & Ceiling Mouldings
and Complements**
Pages 46 - 47



**Instructions Tradicional
Ceiling Tiles**
Pages 55 - 56



Mixed Ceiling
Page 24



Decorative Cornices
Pages 37 - 39



Perimetral Fittings
Pages 48 - 49

This capital can be used as a table column (see page 31)

▼ **Great Capital**
Ref.: 081133



Column ▲
Ref.: 081134

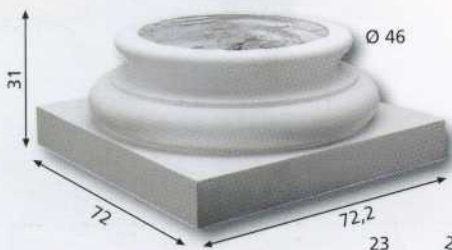

Base ▲
Ref.: 081135

Grooved Jonica ▲
Ref.: 081113



Grooved Compuesta ▲
Ref.: 081122



Square Column nº 2 ▲
Ref.: 081121



Square Column nº 1 ▲
Ref.: 081120



Smooth Jonica ▲
Ref.: 081112

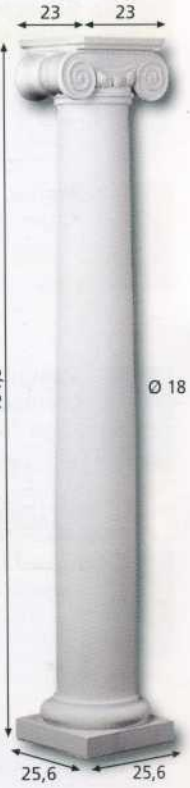

Compuesta ▲
Grooved Ref.: 081117
Smooth Ref.: 081116



Jonica ▲
Smooth Ref.: 081115
Grooved Ref.: 081114

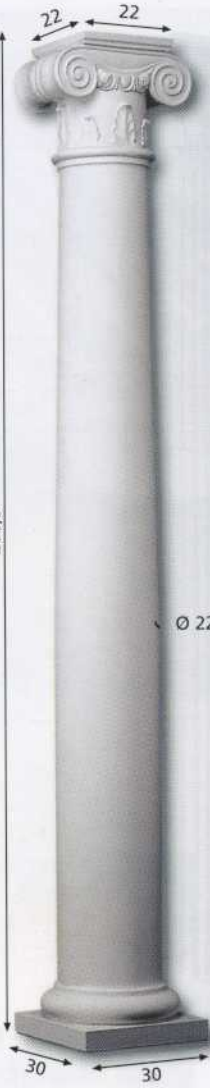

Dorica ▲
Smooth Ref.: 081110
Grooved Ref.: 081111

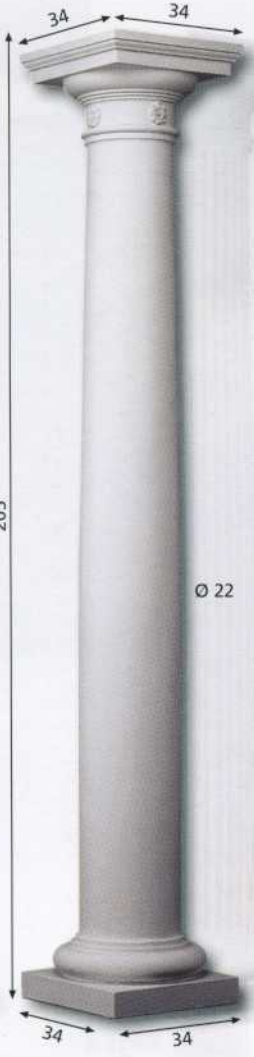

For other measures, ask to Sales Department

Columns

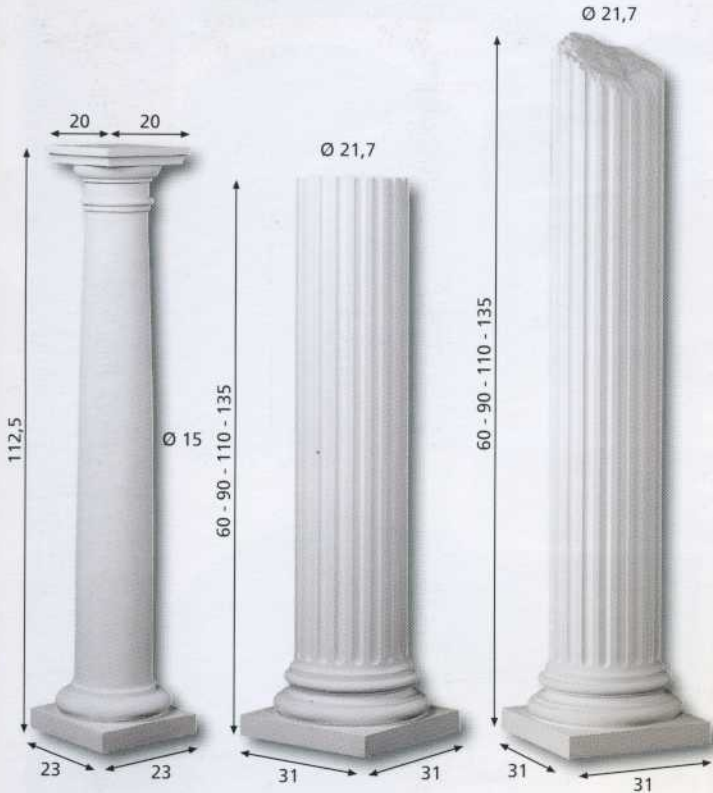

▲
Smooth Toscana
Ref.: 081109

▲
Cut Grooved
Ref.: 081101-2-3-4

▲
Truncated Grooved
Ref.: 081105-6-7-8



▲
Table Column 90
Ref.: 081136

▲
Table Column 73
Ref.: 081131

▲
Table Column 42
Ref.: 081132

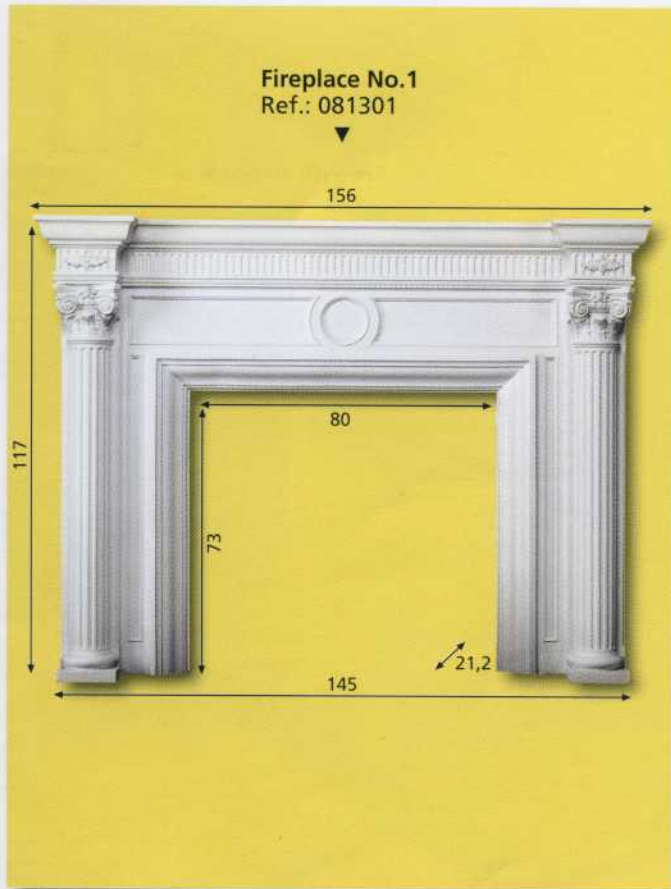

Fireplaces

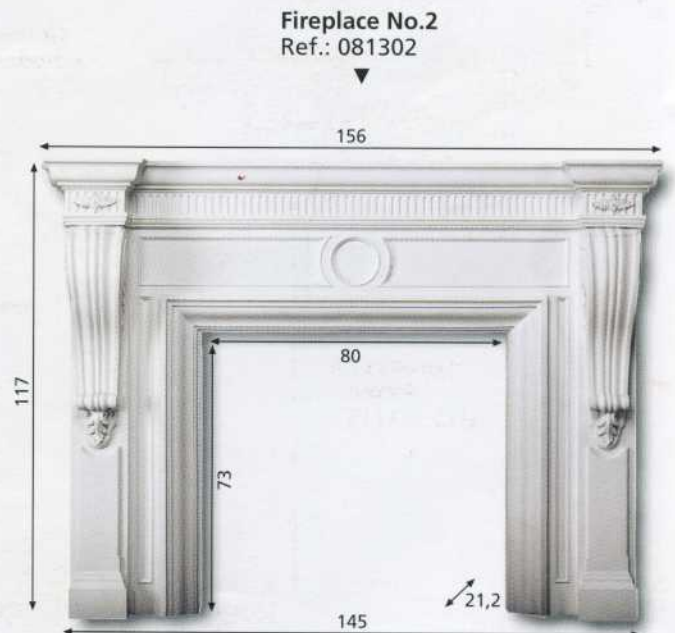

Bookcases



◀ **Bookcase 1**
Built with shelves of 30 and 40x4x120 cm



Shelf Base ▶
Ref.: 050151

Moulding Shelf ▶

Ref.:	P
050220	20
050230	30
050240	40
050250	50

Shelf ▶

Ref.:	P
050120	20
050125	25
050130	30
050135	35
050140	40
050145	45
050150	50



▼ **Bookcase 2** Built with moulding shelves, shelf arches Ø100cm, pilaster with base and pilaster with capital of 8x80 cm.



◀ **Bookcase 2** Built with moulding shelves, shelf arches Ø80 cm, pilaster with base and pilaster with capital of 4x80 cm.

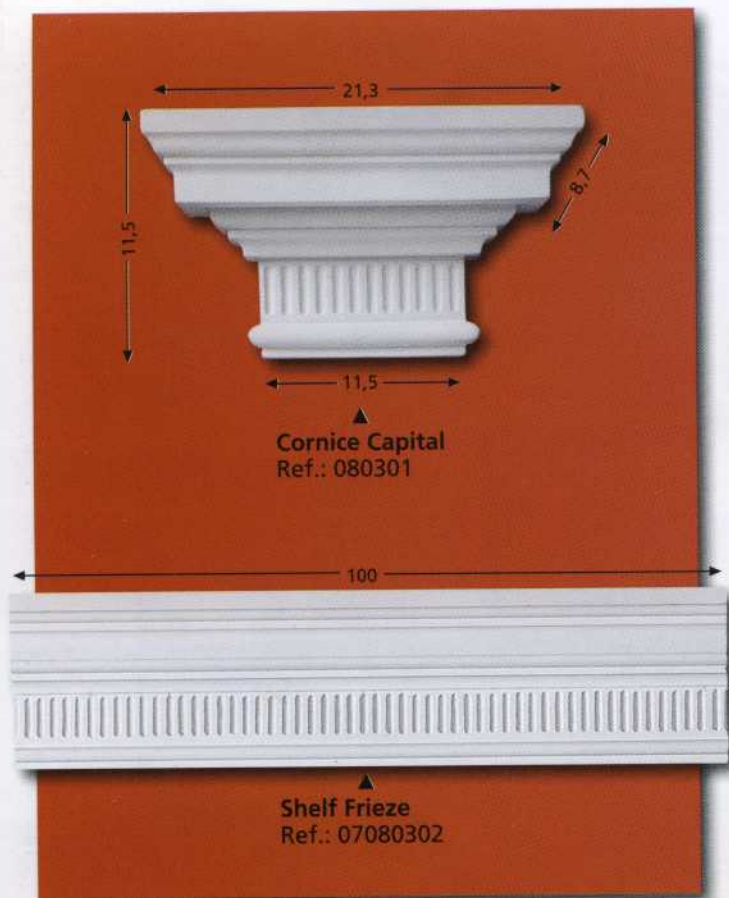

Cornice Capital
Ref.: 080301

Shelf Frieze
Ref.: 07080302

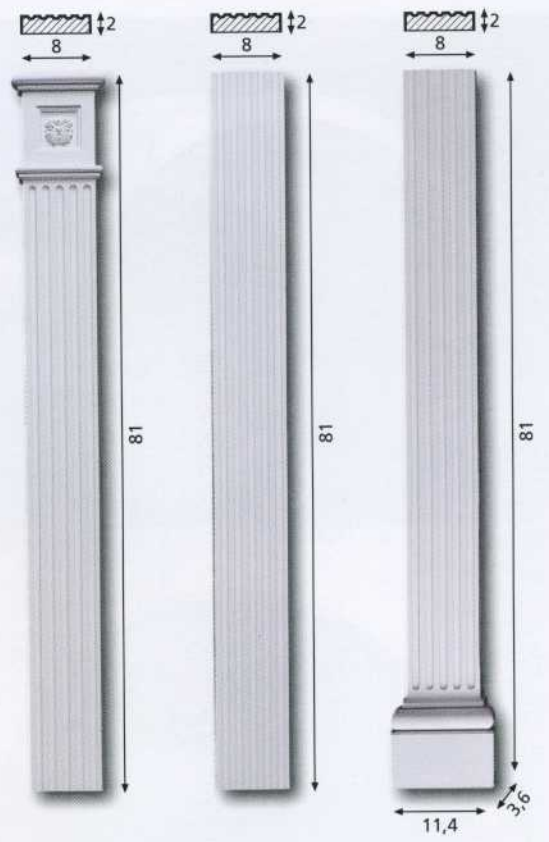

Pilaster with Capital
Ref.: 080304

Extender
Ref.: 080310

Pilaster with Base
Ref.: 080306



◀ **Bookcase 3**
Built with moulding shelves of 4x30x120, cornice capital of 11.5x21.3x8.7, pilasters with base and shelf friezes of 11.5x6.5x100

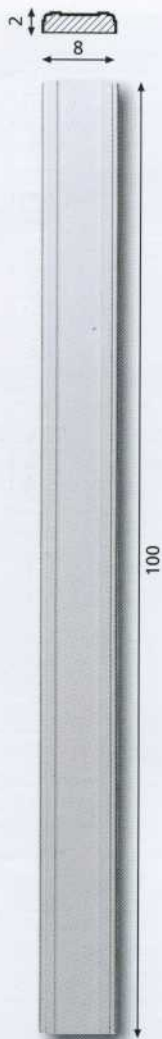

▲
Pilaster for Decorative Arch
Ref.: 080314

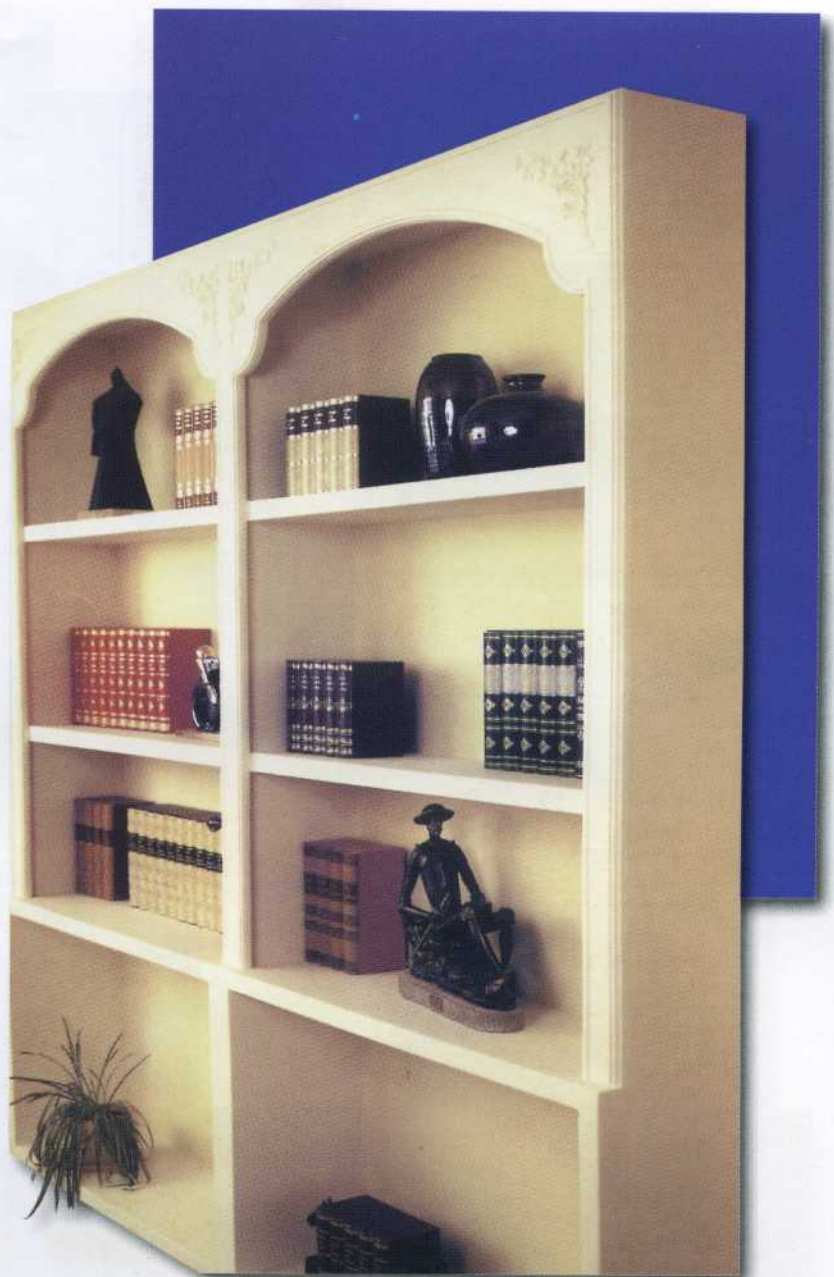

▲
Bookcase 4 Built with pilasters for decorative arch and with decorative arch



Bookcases

Decorative Arch
n°1. Ref.: 080311
n°2. Ref.: 080312

▼
n°1. 115,4 - n°2. 96,8

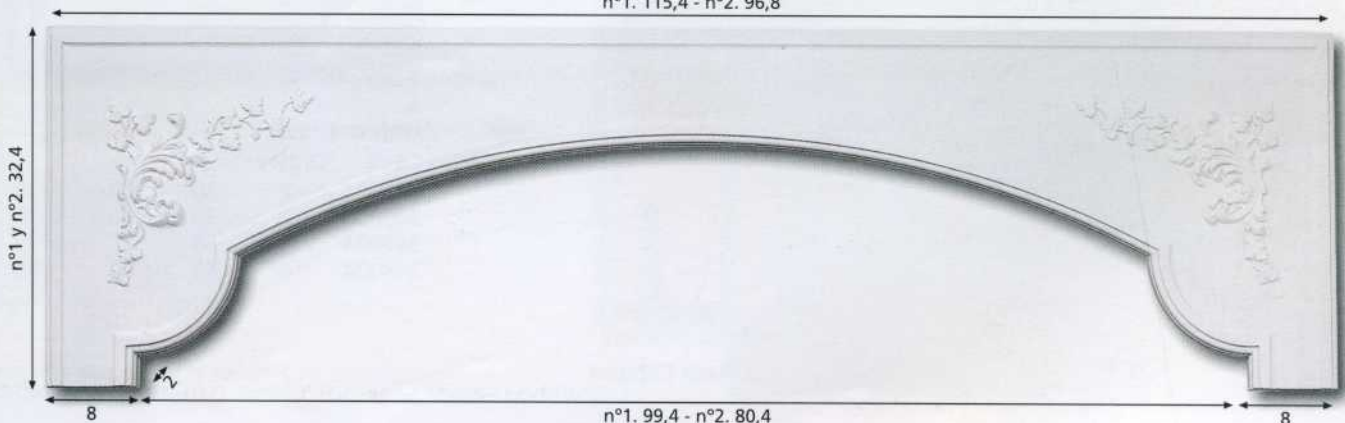

Bookcases

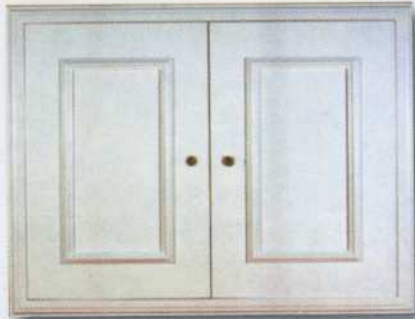

▲ Junquillo Door

Code	Door	↓	↔
341260	2	55	60
341270	2	55	70
341280	2	55	80
341290	2	55	90
341140	1	55	40
341150	1	55	50

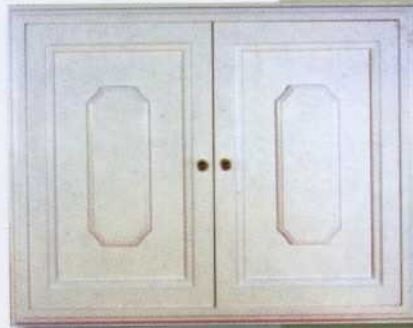

▲ Plafon Door

Code	Door	↓	↔
342260	2	55	60
342270	2	55	70
342280	2	55	80
342290	2	55	90
342140	1	55	40
342150	1	55	50

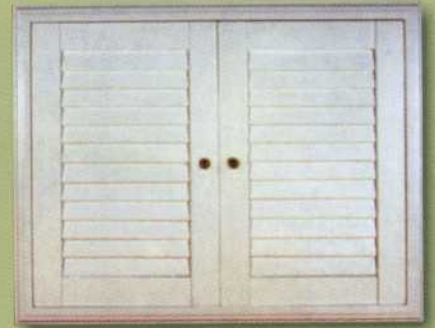

▲ Lamas Door

Code	Door	↓	↔
343260	2	55	60
343270	2	55	70
343280	2	55	80
343290	2	55	90
343140	1	55	40
343150	1	55	50



▲ Provenzal Cabinet

Provenzal	↓	↔
344201	90	40
344202	90	70
344203	160	40
344204	160	70



▲ Double Provenzal Cabinet

Double Provenzal	↓	↔
345201	90	40
345202	90	70
345203	160	40
345204	160	70



▲ Junquillo Drawer

Code	Drawer	↓	↔	↗
349001	2	30	60	39
349002	2	30	70	39
349003	4	55	60	39
349004	4	55	70	39



▲ Square Cabinet

Square	↓	↔	Arch
346201	90	40	347201
346202	90	70	347202
346203	100	50	347203
346204	100	80	347204
346205	160	40	347205
346206	160	50	347206
346207	160	70	347207
346208	160	80	347208



▲ Arch Cabinet



▲ Plafon Drawer

Code	Drawer	↓	↔	↗
348001	2	30	60	39
348002	2	30	70	39
348003	4	55	60	39
348004	4	55	70	39

Finishes in white, oak and pine.

Arches



▲ Arch No. 1
Ref.: 080201

The length of the arch can be reduced to a minimum of 82 cm by cutting it ends.



◀ Corbel No. 6
Ref.: 07080906

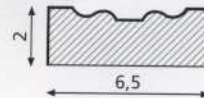

▼ Arch No. 2
Ref.: 080202

The length of the arch can be reduced to a minimum of 82 cm by cutting it ends.



◀ Grooved Pilaster No.1
Ref.: 07080500

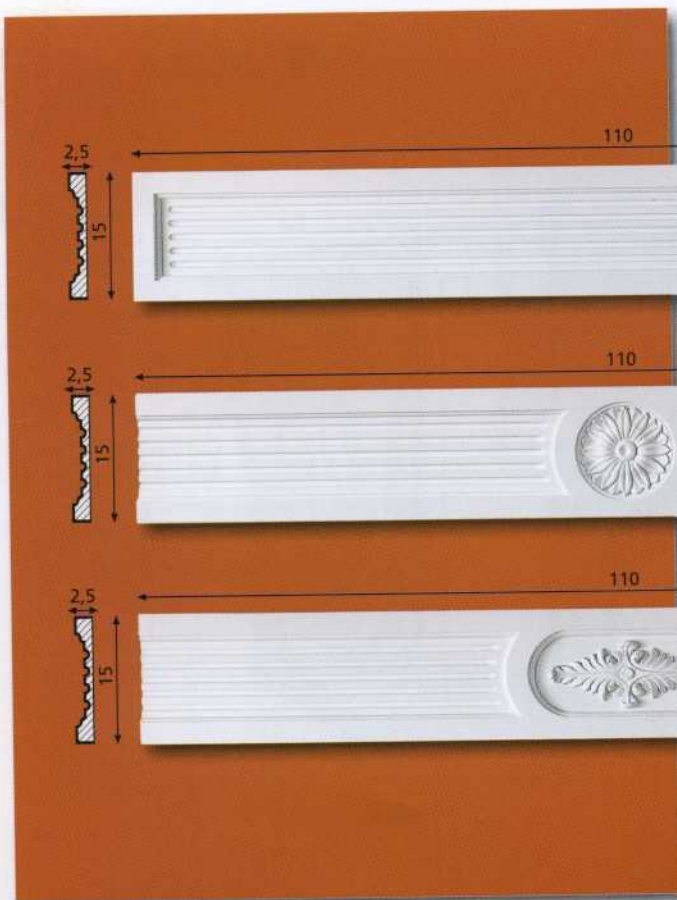

◀ Grooved Pilaster No.3
Ref.: 07080503

◀ Flower Pilaster No. 1
Ref.: 07080501

◀ Flower Pilaster No. 2
Ref.: 080502

Arch No. 3
with grooved pilaster No. 3
Ref.: 080203

The length of the arch can be reduced to a minimum of 88 cm by cutting it ends.

Mixed Arch ▼

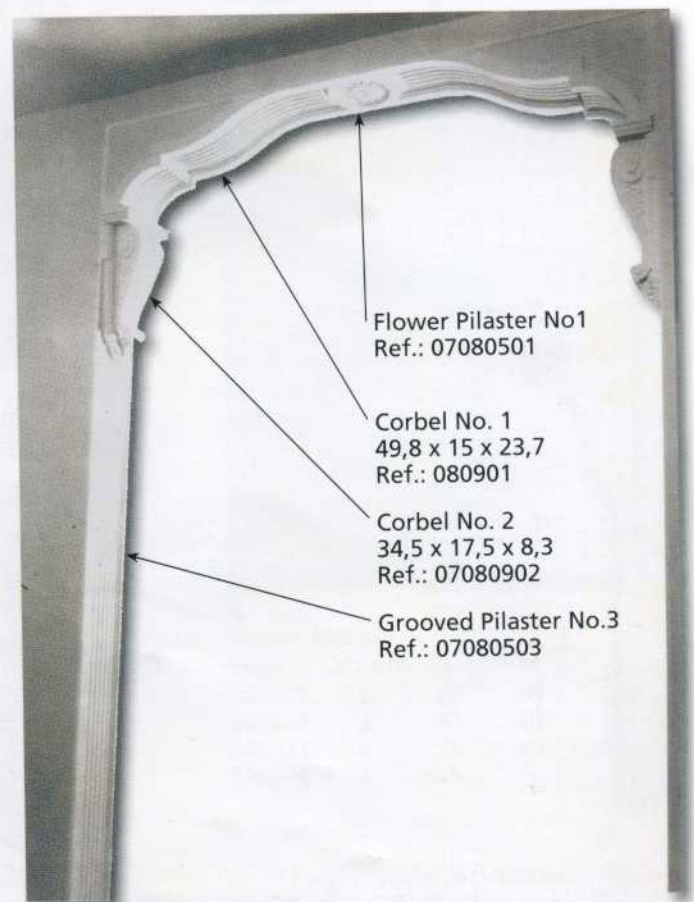
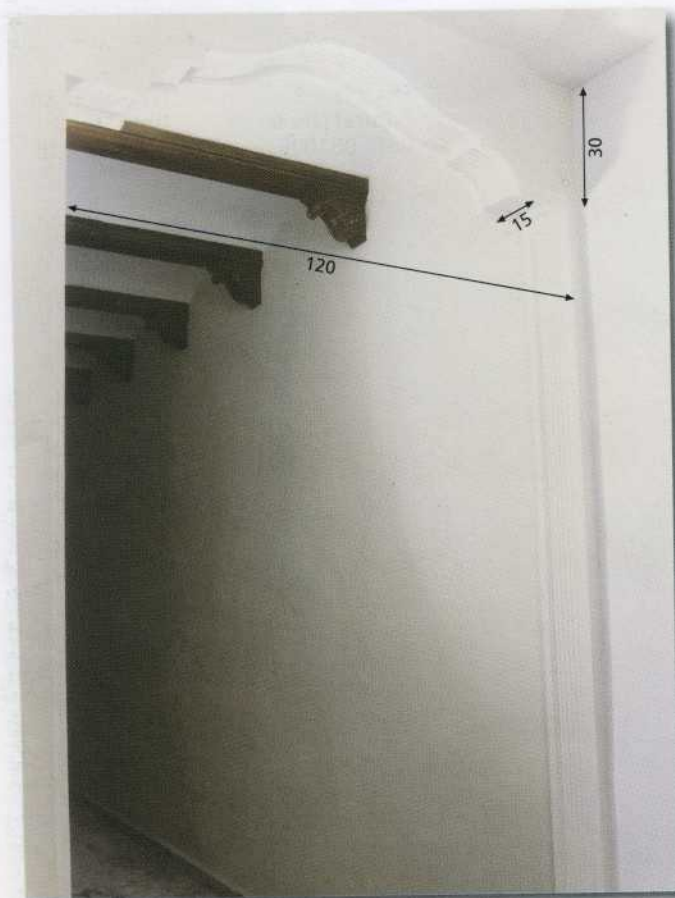

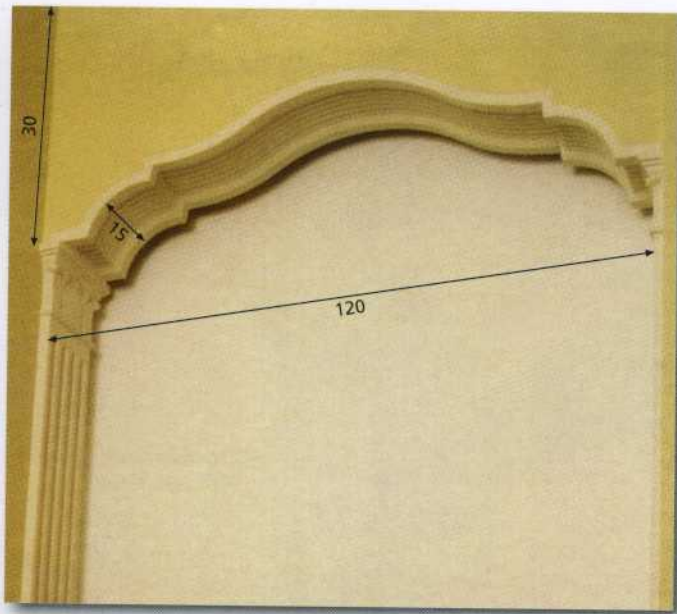

▲
Arch No. 3
 with pilaster with capital and with base No. 6
 Ref.: 080203

Arches



▲ **Pilaster No. 6** Ref.: 07080506
 ▲ **Pilaster with Capital No. 6** Ref.: 081026
 ▲ **Pilaster with Base No. 6** Ref.: 081016



▲ **Extender No. 7** Ref.: 07080607
 ▲ **Column Pilaster No. 7** Ref.: 07080507

▼ **Arch No. 3, with column pilaster No.7 and extender n°7**
 Ref.: 080203

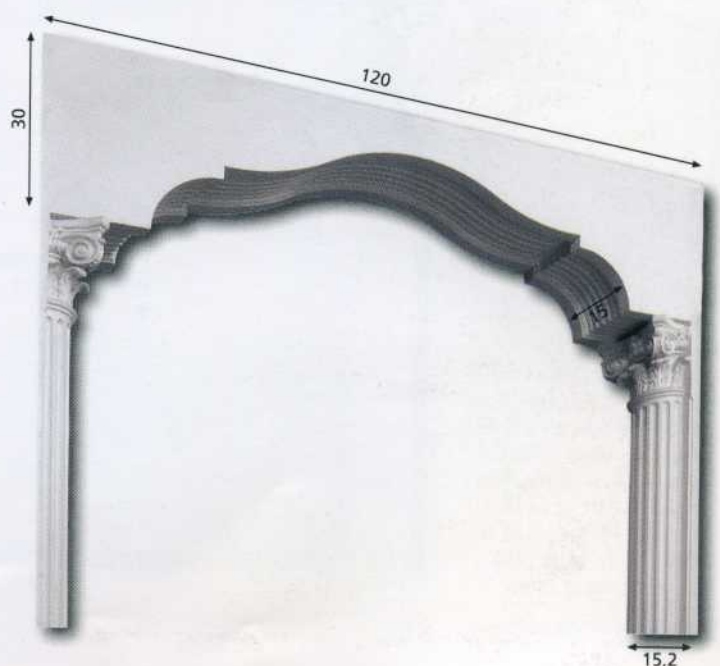

Arches



▲ **Half Arch No. 4**
Ref.: 080204

▼ **Pilaster No. 4**
Ref.: 07080504

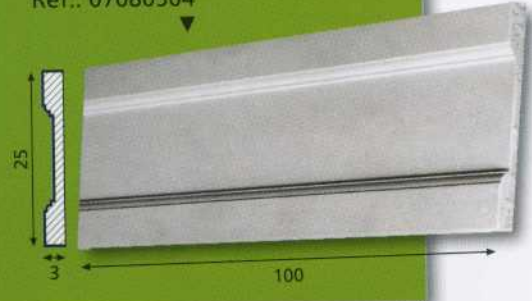

◀ **Double Corbel No. 4**
Ref.: 080954

▶ **Arch Base No. 4**
Ref.: 081054



▶ **Arch No. 4**
Ref.: 080204

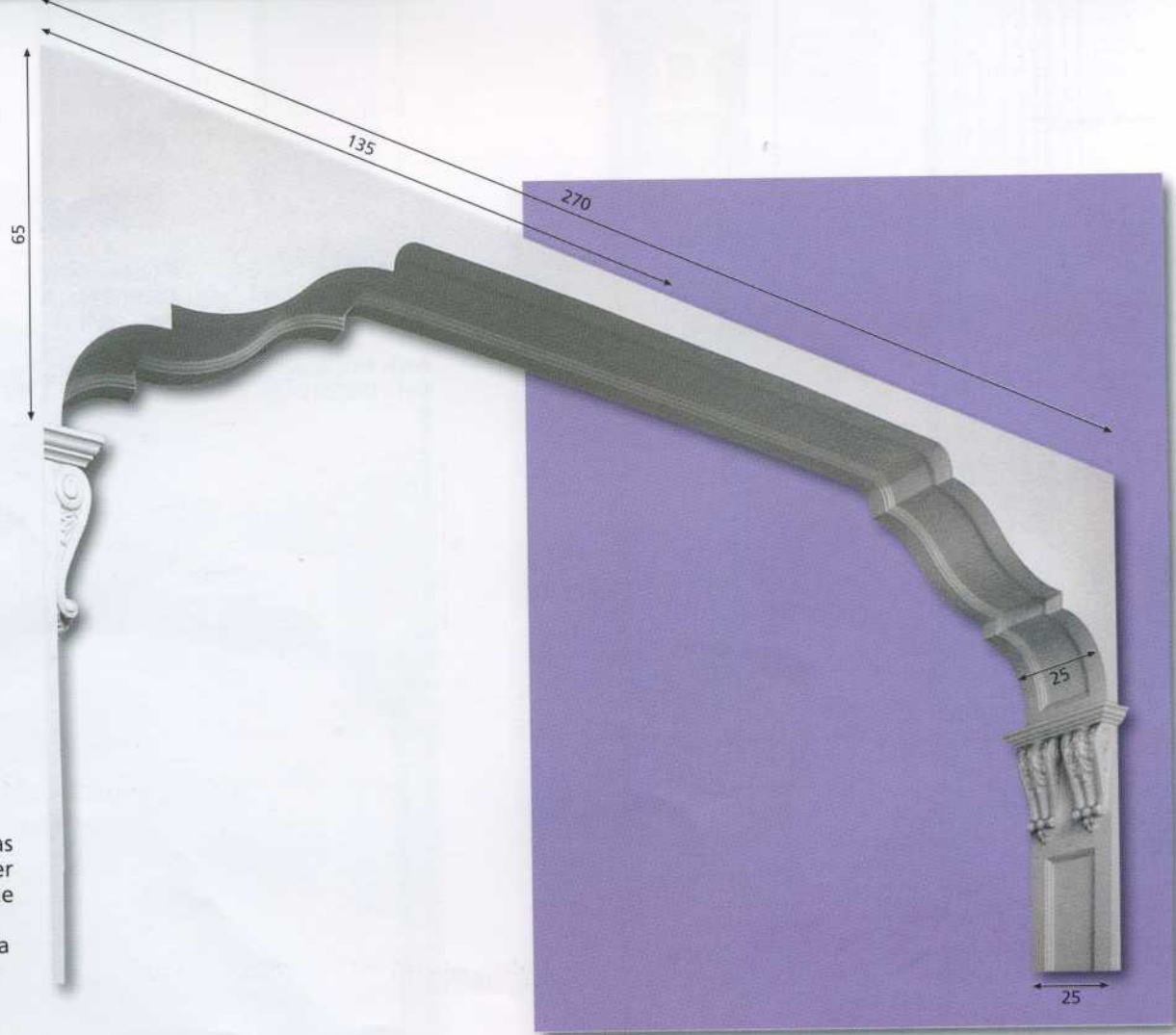

The arch can be enlarged as much as desired with pilaster No. 4. Moreover, the length of the arch can be reduced to a minimum of 88 cm by cutting it ends.

Arch No. 5 ▶
Ref.: 080205



The width of the arch can be enlarged as much as desired with pilaster No. 5

Arch Base No. 5 ▲
Ref.: 081055

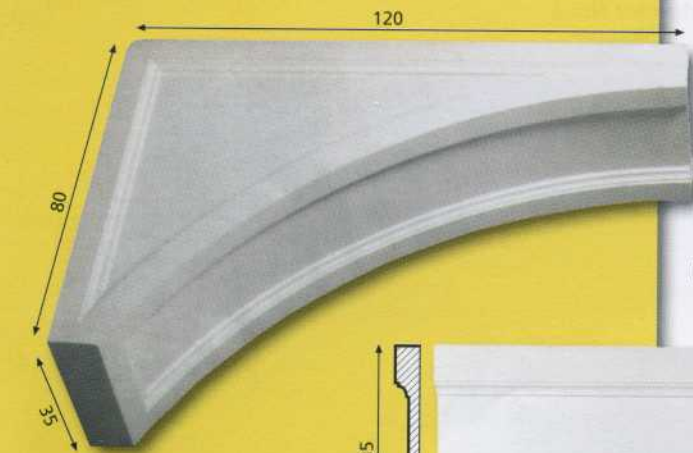

Half Arch No. 5 ▲
Ref.: 080205



Extender No. 5
Ref.: 080605



Double Corbel No. 5
Ref.: 080955

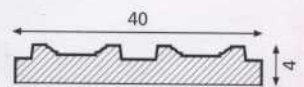

Double Pilaster No. 5 ▶
Ref.: 080555

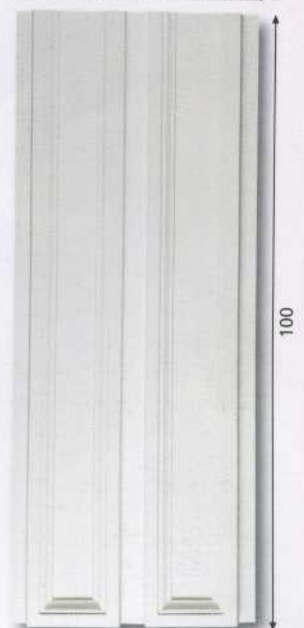

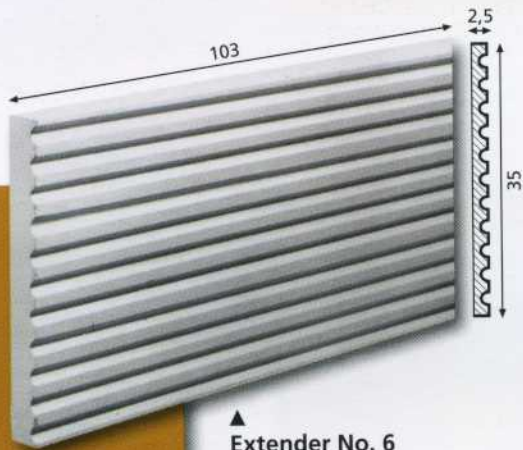
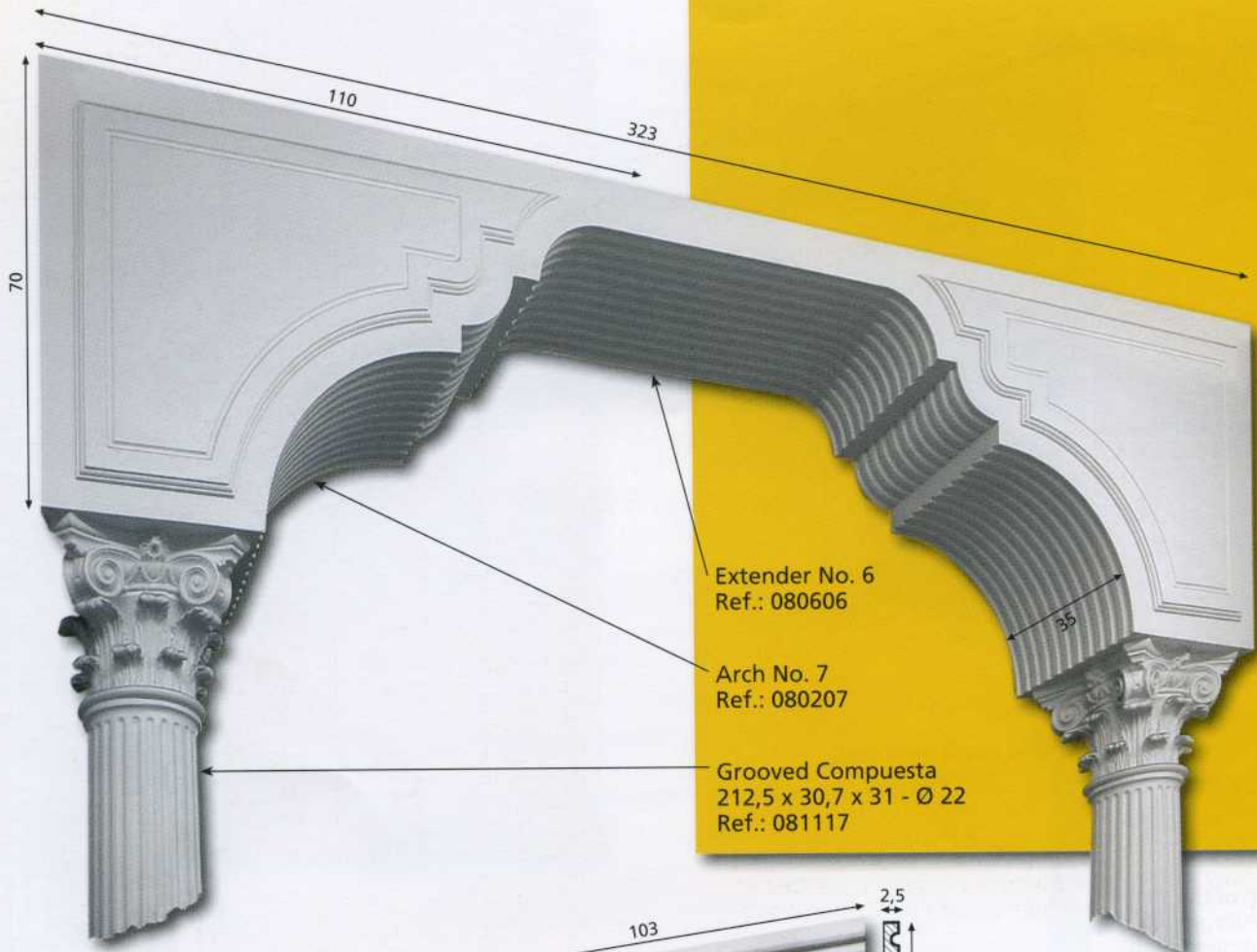

▲
Extender No. 6
Ref.: 080606

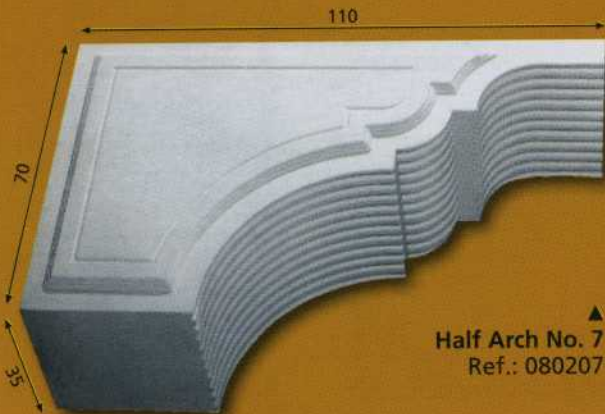

▲
Half Arch No. 7
Ref.: 080207

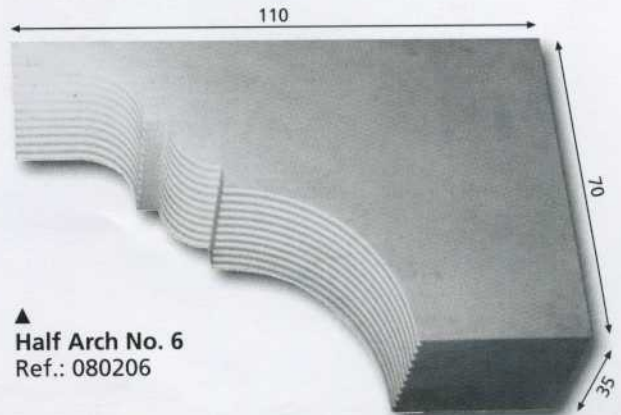

▲
Half Arch No. 6
Ref.: 080206

Arches

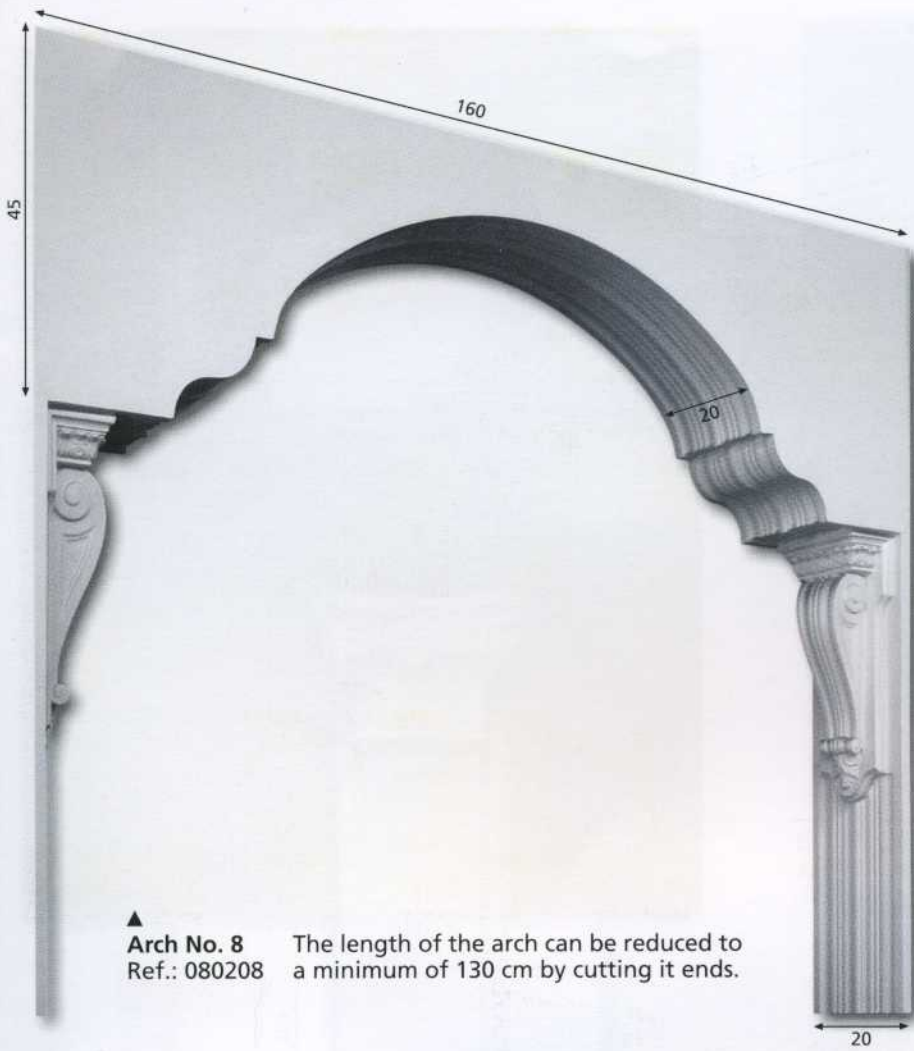

▲ **Arch No. 8**
Ref.: 080208 The length of the arch can be reduced to a minimum of 130 cm by cutting it ends.



▲ **Corbel No. 10**
Ref.: 07080910



▲ **Pilaster No. 8**
Ref.: 07080508

Note: This Arch can be built with pilasters with base and pilasters with capital No. 9 (see page 16).

This arch can be built with pilaster No. 8 and corbel No. 10 (see page 15).

Extender No. 9 ▶
Ref.: 080609



Arch No. 9 ▼ The length of the arch can be reduced to a minimum of 120 cm by cutting its ends.
Ref.: 080209

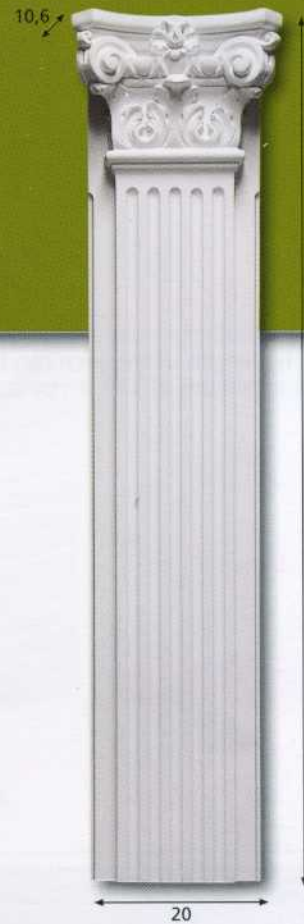

Pilaster with Capital No. 9 ▲
Ref.: 07080559



Pilaster with Base No. 9 ▶
Ref.: 07080509



Arch No. 10
Ref.: 080210

The length of the arch can be reduced to a minimum of 90 cm by cutting it ends.

Pilaster No. 10 ▶
Ref.: 080510

Corbel No. 29 ▶
Ref.: 080929

Arches

The length of the arch can be reduced to a minimum of 110 cm by cutting it ends.

Arch No. 11
Ref.: 080211

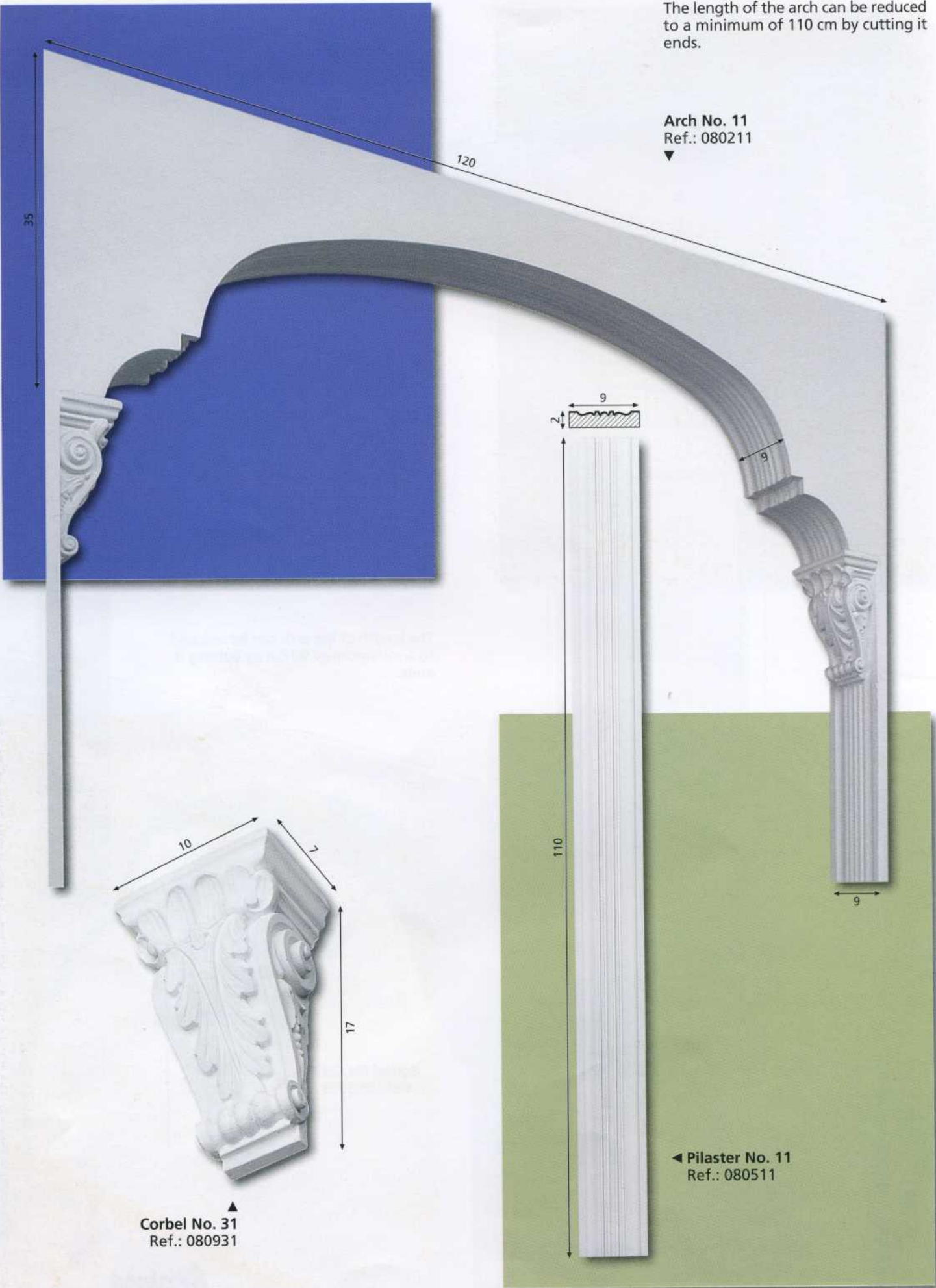

Corbel No. 31
Ref.: 080931

Pilaster No. 11
Ref.: 080511

Arches

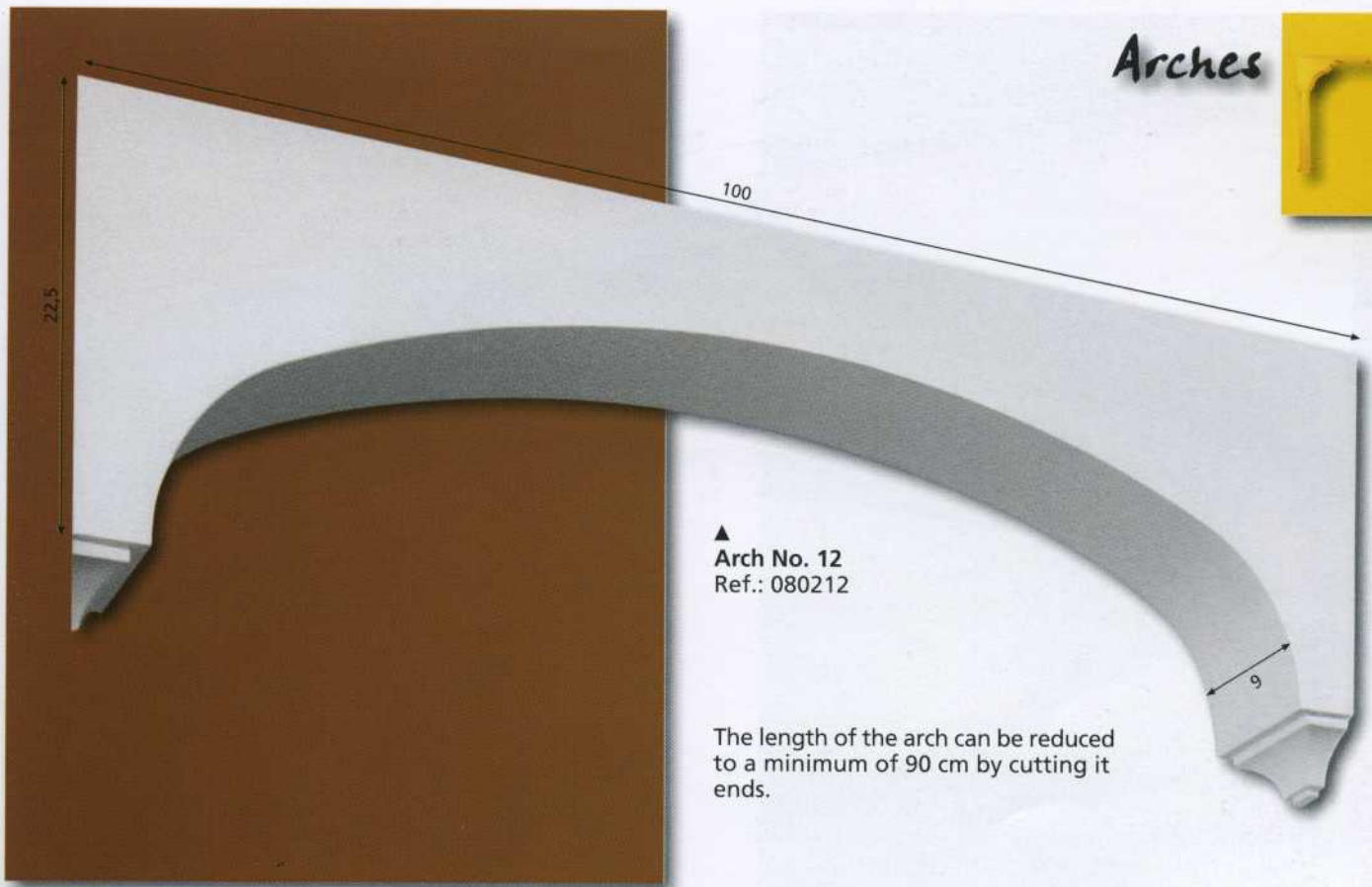

▲ Arch No. 12
Ref.: 080212

The length of the arch can be reduced to a minimum of 90 cm by cutting it ends.

Corbel No. 18 ▶
Ref.: 080918



Arch No. 13
Ref.: 080213

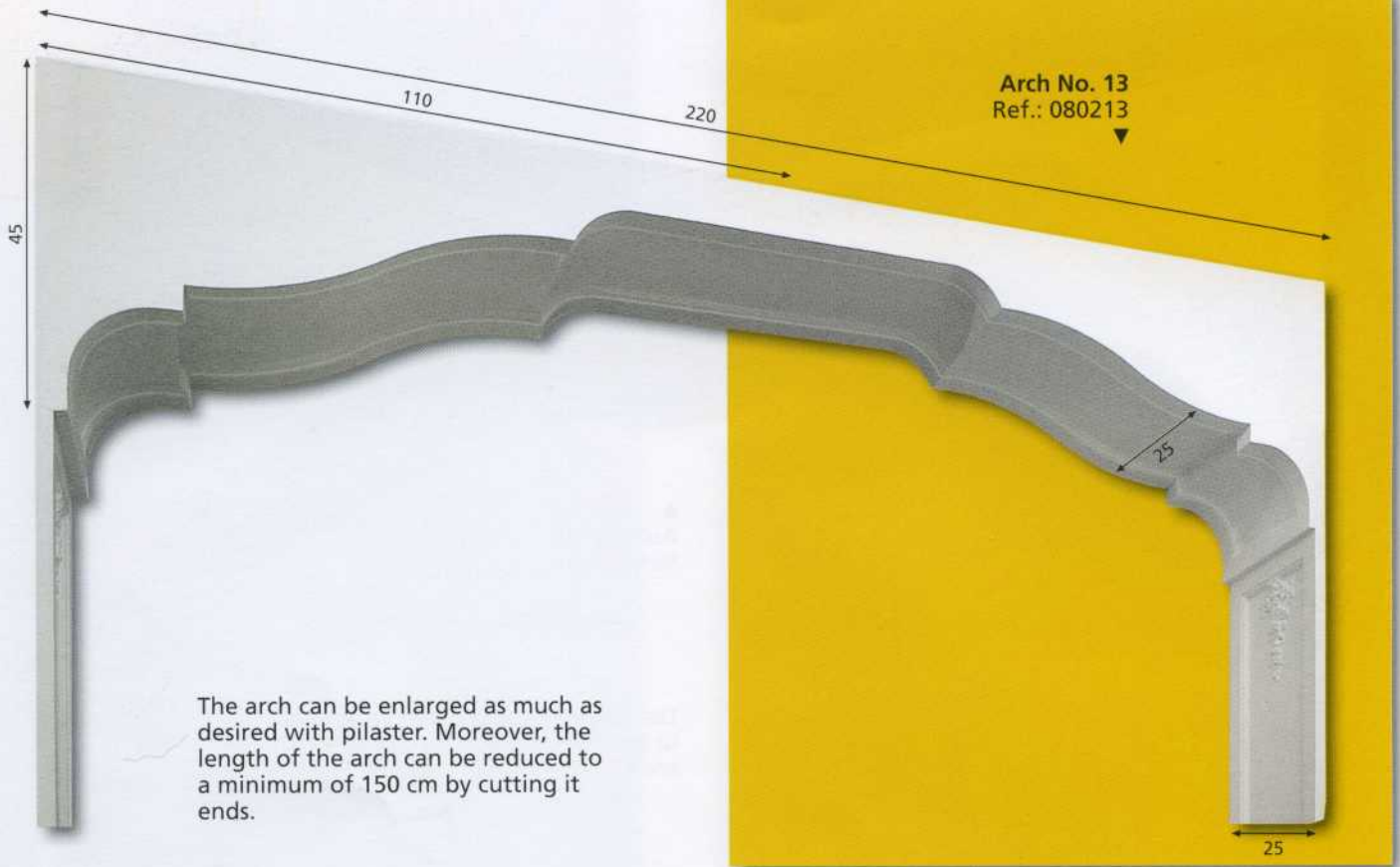

The arch can be enlarged as much as desired with pilaster. Moreover, the length of the arch can be reduced to a minimum of 150 cm by cutting it ends.

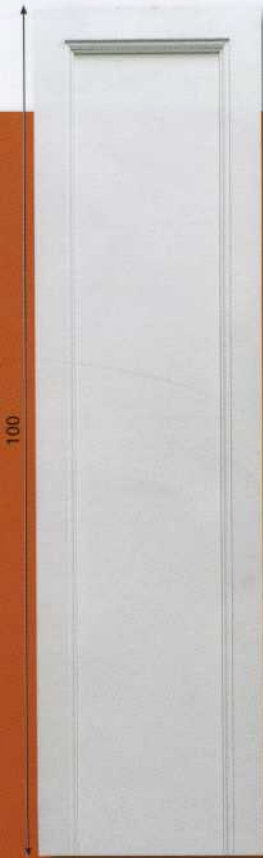
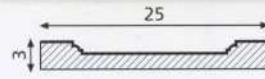
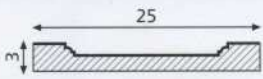

Pilaster No. 12
Ref.: 080512

Pilaster No. 13
Ref.: 080513

Pilaster No. 13
Ref.: 080514

Pilaster No. 14
Ref.: 080515



Arches



Arch No. 14
Ref.: 080214

The length of the arch can be reduced to a minimum of 100 cm by cutting it ends.



Pilaster No. 16
Ref.: 080516

Pilaster No. 17
Ref.: 080517



Corbel No. 31
Ref.: 080931



Arches

The length of the arch can be reduced to a minimum of 118 cm by cutting it ends.



Arch No. 15
Ref.: 080215

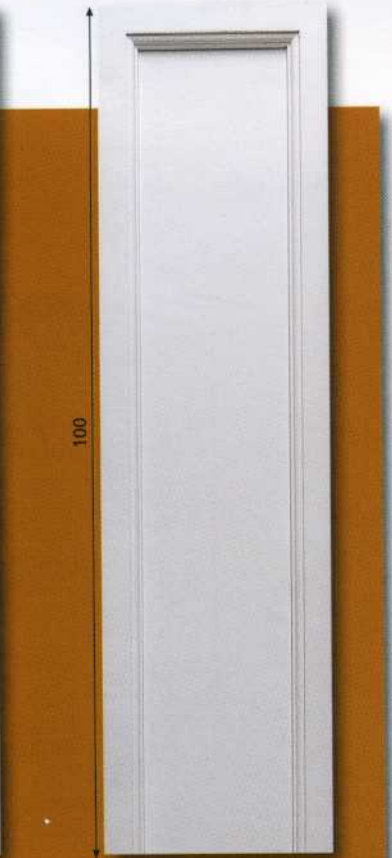
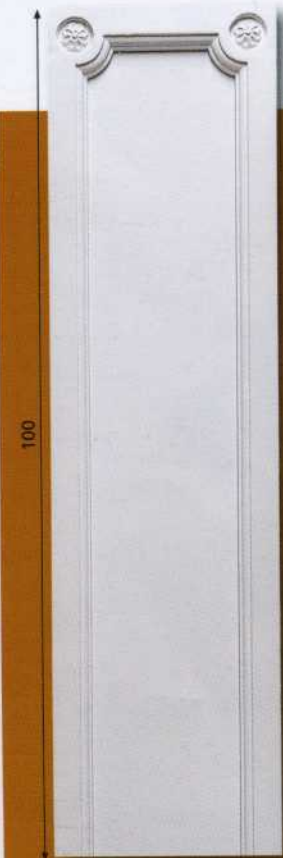
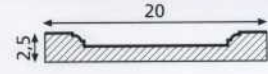
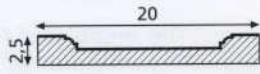
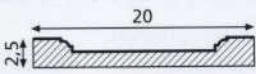

Corbel No. 2
Ref.: 07080902

Pilaster No. 18
Ref.: 080518

Pilaster No. 19
Ref.: 080519

Pilaster No. 20
Ref.: 080520

Multiple Steps Cornice 5x5x5



Multiple Steps Convex Corner
Ref.: 080106

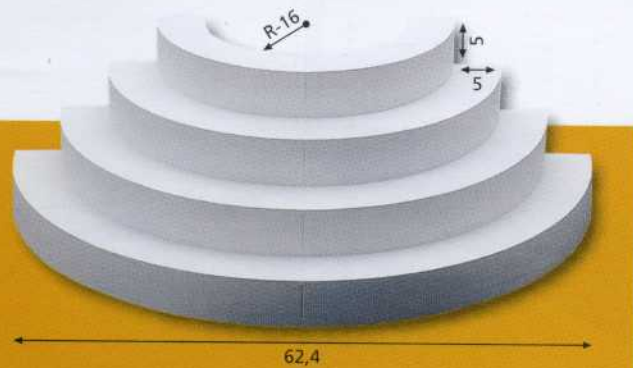

Multiple Steps Concave Corner
Ref.: 080105

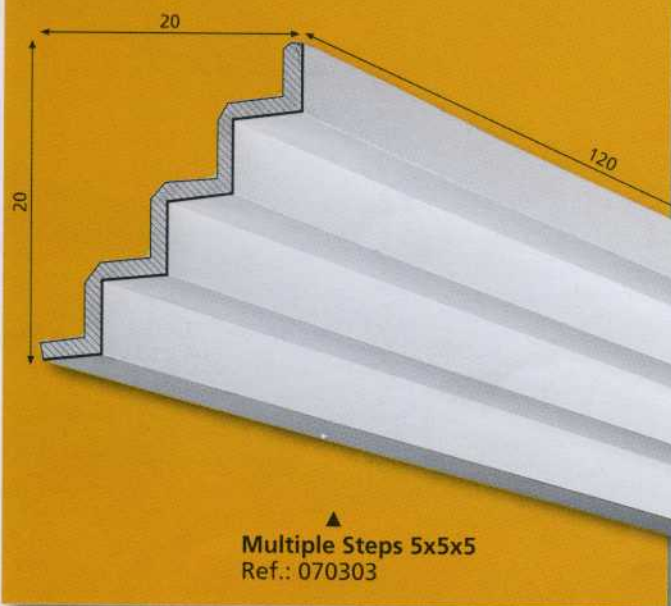
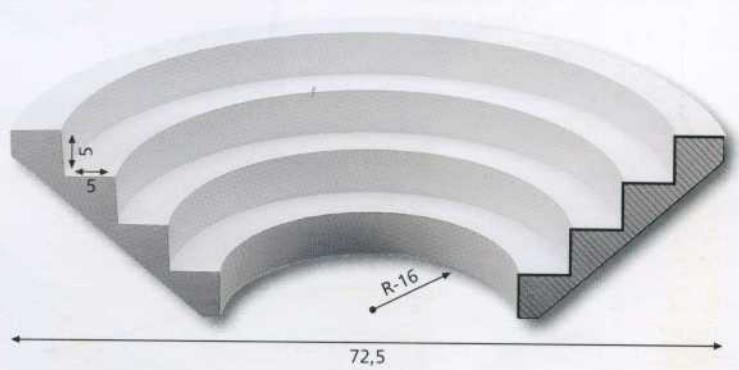

Multiple Steps 5x5x5
Ref.: 070303

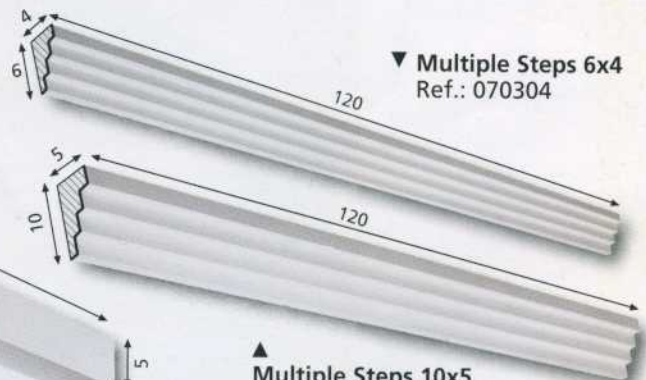

Multiple Steps 6x4
Ref.: 070304

Multiple Steps 10x5
Ref.: 070302

Multiple Steps Cornices

Mixed Ceiling

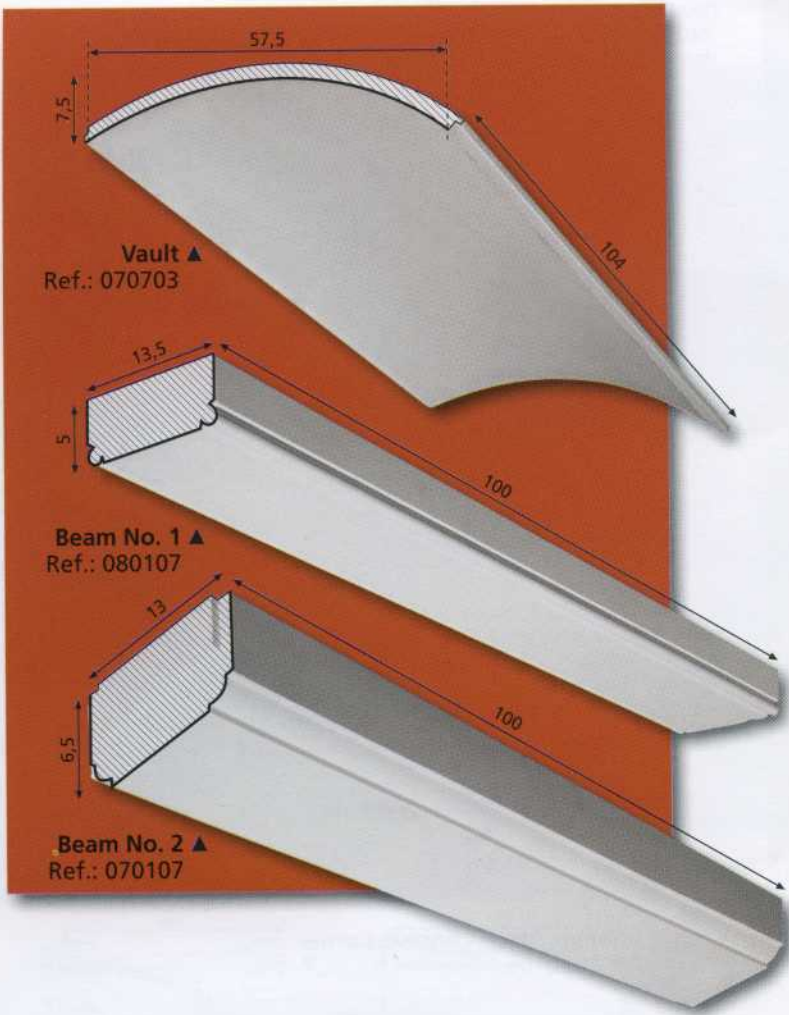

▲ **Corbel No. 3**
Ref.: 07080903



Mixed Ceiling ▶
Vaults
Beams
Corbels



◀ Indirect Lighting Tray
Ref.: 070451

Indirect Lighting Concave Tray
Ref.: 080103

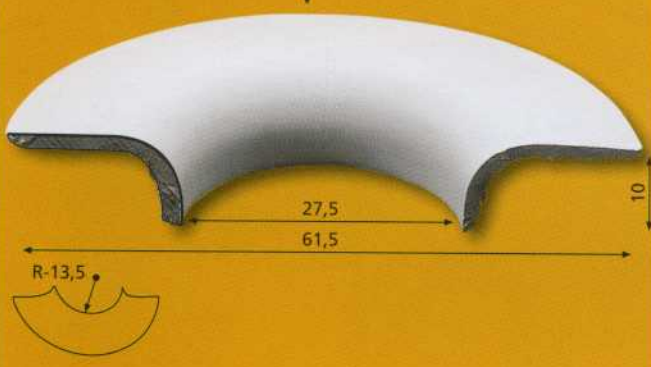

Indirect Lighting Convex Tray
Ref.: 080104

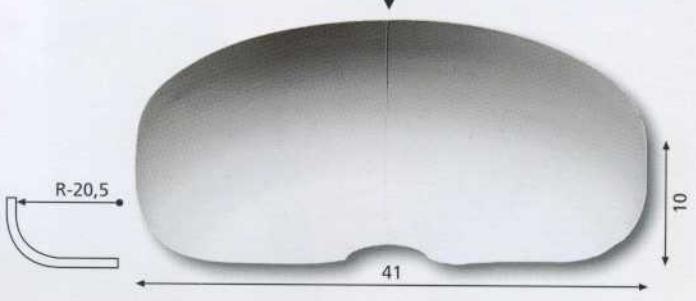

◀ Indirect Lighting Cornice
Ref.: 070452



▲ Indirect Lighting Concave Cornice
Ref.: 080101

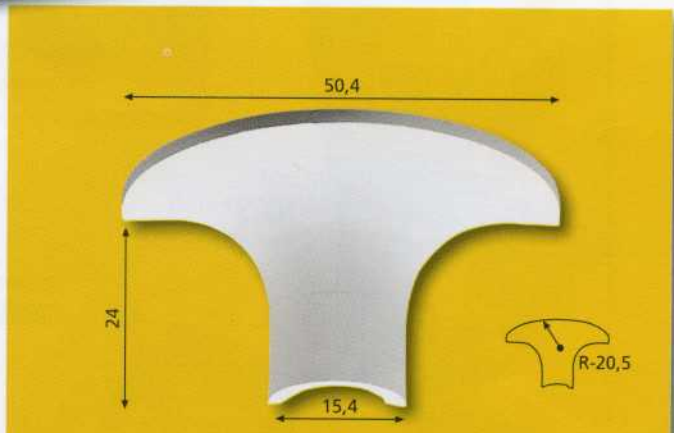

▲ Indirect Lighting Convex Cornice
Ref.: 080102

Indirect Lighting ▶
Tray No. 2
Ref.: 020502

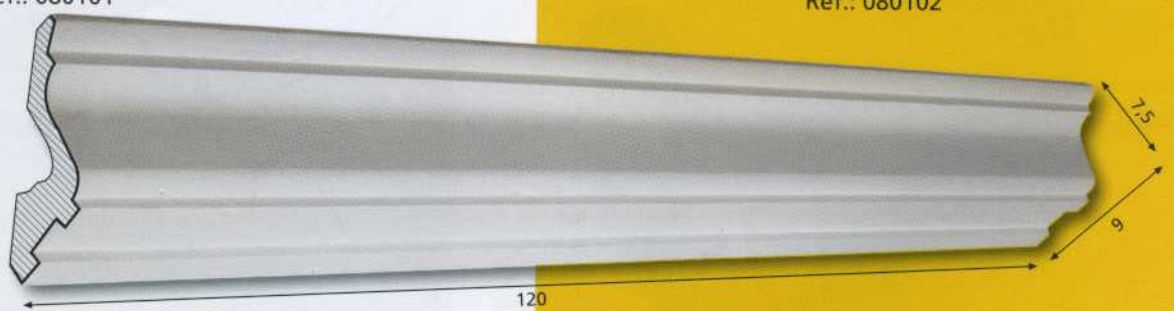

Indirect Lighting





Corbels

No. 1 ▶
Ref.: 080901

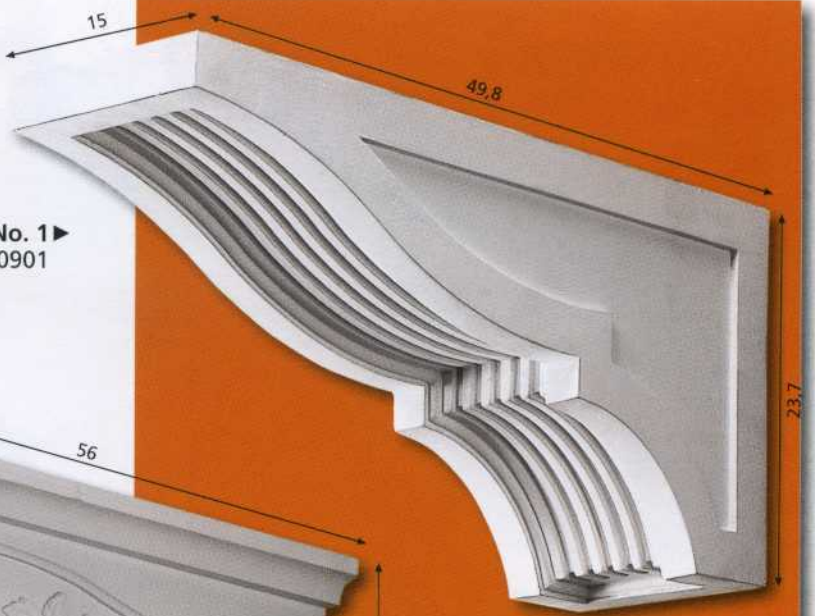

No. 12 ▶
Ref.: 080912



No. 10 ▶
Ref.: 07080910



No. 11 ▶
Ref.: 080911



▲ No. 7
Ref.: 080907





◀ No. 14
Ref.: 07080914



▼ No. 15
Ref.: 07080915



▲ No. 16
Ref.: 07080916



▲ No. 17
Ref.: 07080917



▶ No. 20
Ref.: 07080920



◀ No. 19
Ref.: 07080919

Corbels



No. 24
Ref.: 080924



No. 31
Ref.: 080931



No. 21
Ref.: 07080921



No. 18
Ref.: 080918

No. 23
Ref.: 080923



No. 29
Ref.: 080929



No. 22
Ref.: 07080922

No. 30
Ref.: 080930





Corbels and Consoles

No. 25
Ref.: 080925



No. 26
Ref.: 080926

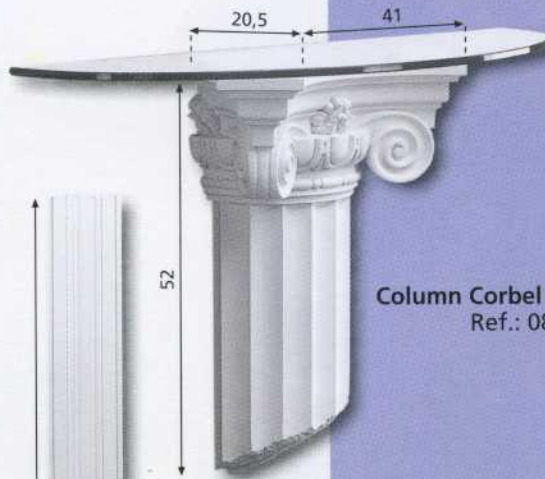

Column Corbel No. 1
Ref.: 081501



Column Corbel No. 2
Ref.: 081502

Pilaster No. 23
Ref.: 080523

With this pilaster and corbels No. 25 or 26 we can built an arch.

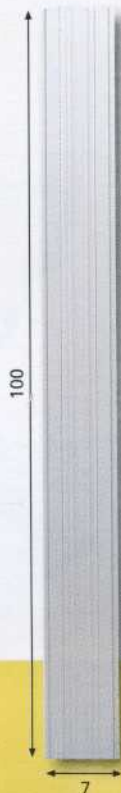

No. 27
Ref.: 080927



Mixed arch built with corbels No. 27 or No. 28 and with pilasters No. 21 or No. 22

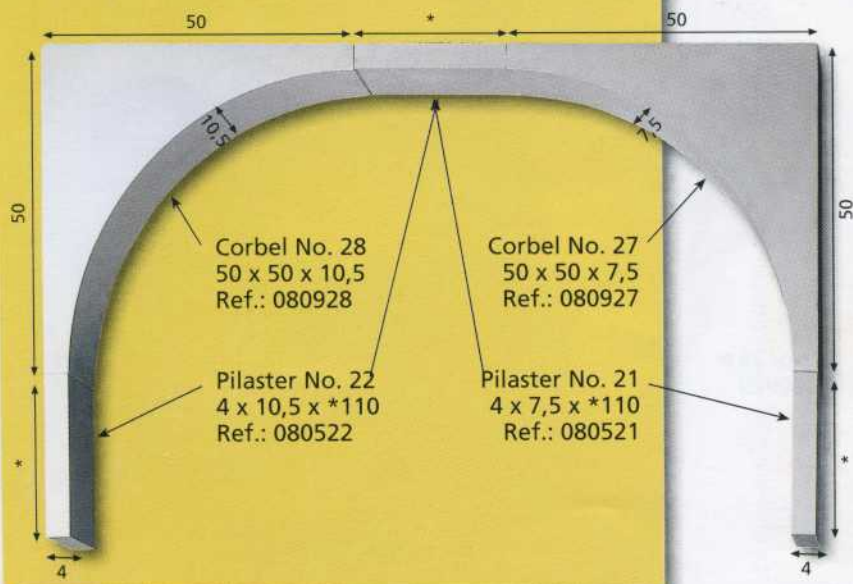

No. 28
Ref.: 080928

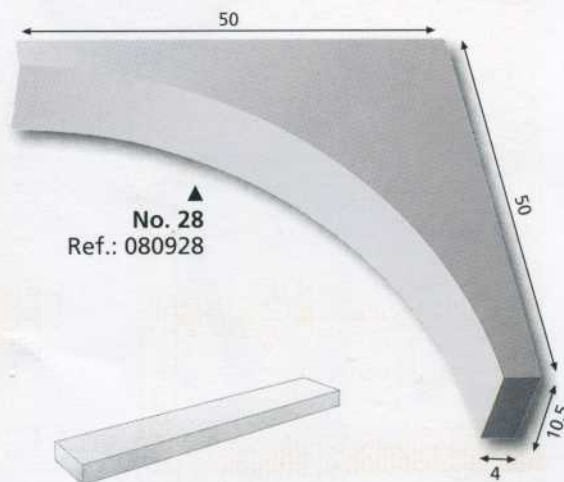

Pilaster No. 21- 4 x 7,5 x 110 - Ref.: 080521
Pilaster No. 22- 4 x 10,5 x 110 - Ref.: 080522

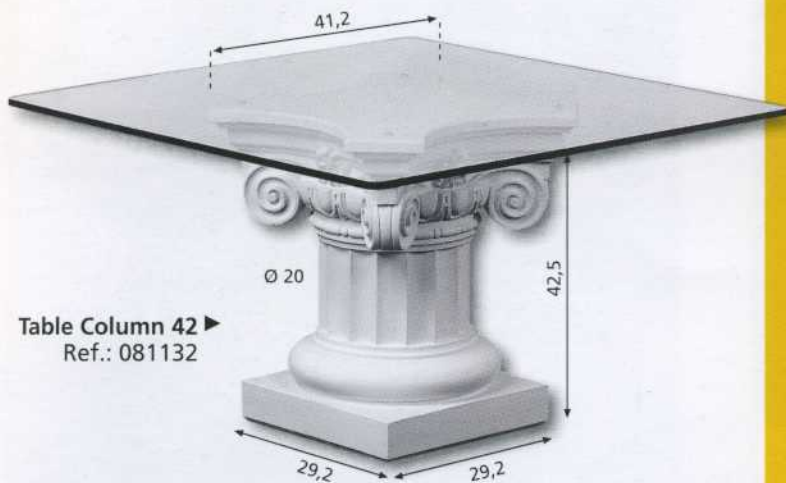
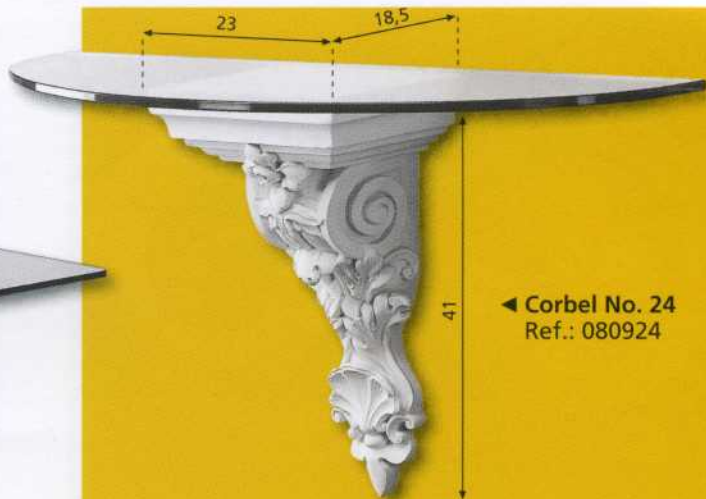

Table Column 42 ▶
Ref.: 081132



◀ Corbel No. 24
Ref.: 080924



◀ Great Capital
Ref.: 081133



◀ Table Column 90
Ref.: 081136



▲
Ceiling Rose No. 1
Ø 40 cm.
Ref.: 070501



▲
Ceiling Rose No. 2
Ø 37 cm.
Ref.: 070502



▲
Ceiling Rose No. 21
Ø 30 cm.
Ref.: 08070521



▲
Ceiling Rose No. 22
Ø 30 cm.
Ref.: 08070522



▲
Ceiling Rose No. 3
Ø 50 cm.
Ref.: 070503



▲
Ceiling Rose No. 4
Ø 55 cm.
Ref.: 070504



▲
Ceiling Rose No. 5
Ø 50 cm.
Ref.: 070505



▲
Ceiling Rose No. 9
Ø 49 cm.
Ref.: 070509

▲
Ceiling Rose No. 6
Ø 34 cm.
Ref.: 070506



▲
Ceiling Rose No. 7
Ø 50 cm.
Ref.: 070507



▲
Ceiling Rose No. 8
Ø 50 cm.
Ref.: 070508

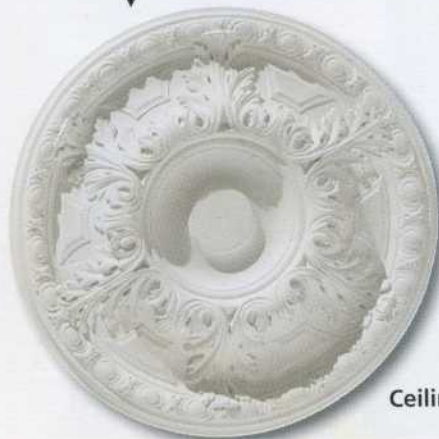

▲
Ceiling Rose No. 10
Ø 57 cm.
Ref.: 070510



▲
Ceiling Rose No. 11
Ø 60 cm.
Ref.: 070511



Ceiling Roses



▲
Ceiling Rose
No. 15
Ø 78 cm.
Ref.: 070515



◀ Ceiling Rose
No. 12
Ø 64 cm.
Ref.: 070512



▶ Ceiling Rose No. 20
Ø 42 cm.
Ref.: 08070520



▲
Ceiling Rose
No. 17
Ø 89 cm.
Ref.: 070517

▼ Ceiling Rose No. 13
Ø 72 cm.
Ref.: 070513



▼ Ceiling Rose No. 18
Ø 95 cm.
Ref.: 070518



▲
Ceiling Rose
No. 16
Ø 79 cm.
Ref.: 070516



▲
Ceiling Rose No. 19
Ø 51 cm.
Ref.: 070519



▲
Ceiling Rose No. 24
Ø 53 cm.
Ref.: 070524



◀
Ceiling Rose No. 25
Ø 53 cm.
Ref.: 070525

Ceiling Rose No. 23
Ø 35 cm.
Ref.: 08070523
▼



Ceiling Rose No. 26
Ø 48 cm.
Ref.: 08070526
▼



Ceiling Roses



▲
Ceiling Rose No. 27
 Ø 40 cm.
 Ref.: 08070527

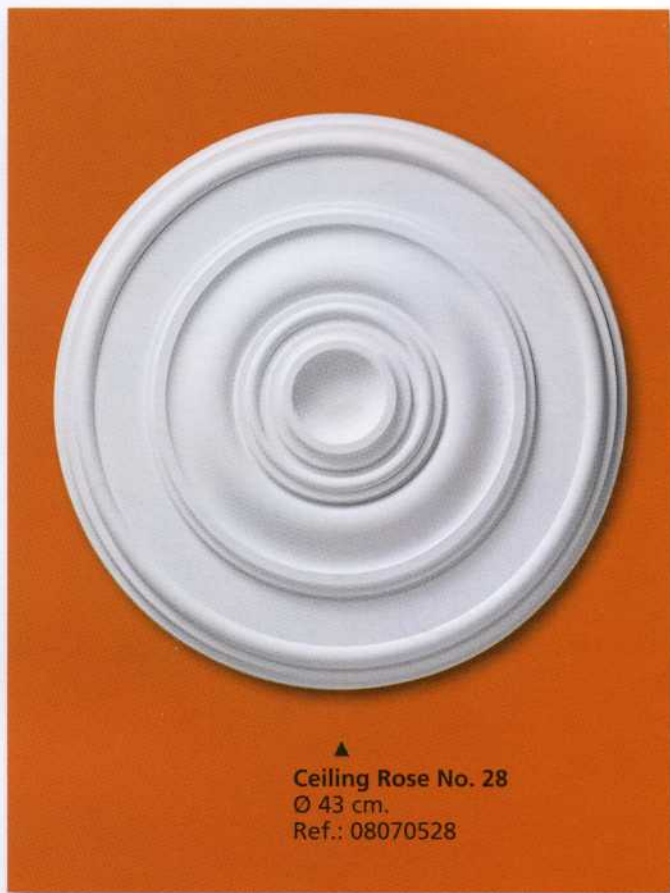

▲
Ceiling Rose No. 28
 Ø 43 cm.
 Ref.: 08070528

Medallion No. 1(L)
 Ø 60 cm.
 Ref.: 081801



Medallion



Medallion No. 2(R)
 Ø 60 cm.
 Ref.: 081802



Wall Lamps



Wall Lamp No. 2
Ref.: 080112



Wall Lamp No. 3
Ref.: 080113

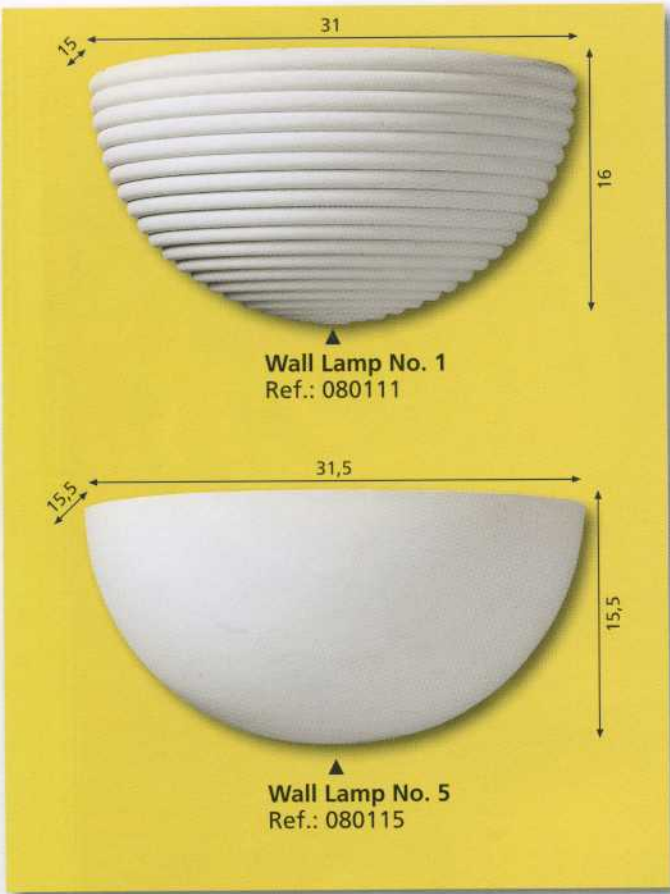
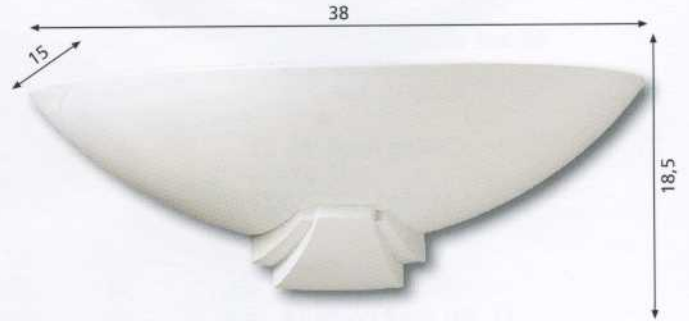

Wall Lamp No. 1
Ref.: 080111

Wall Lamp No. 5
Ref.: 080115

Wall Lamp No. 4
Ref.: 080114

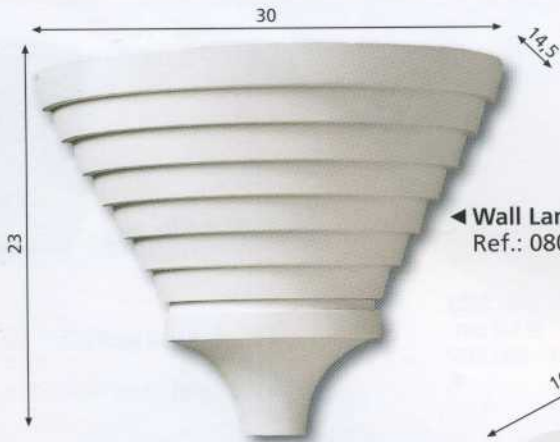

Wall Lamp No. 6
Ref.: 080116



Wall Lamp No. 7
Ref.: 070706



Wall Lamp No. 8
Ref.: 080118

Decorative Cornices



Cornice No. 7
Ref.: 070407
Wall & Ceiling
Moulding No. 1
Ref.: 020151
Corner No. 5
Ref.: 070605

Cornice No. 7 ▶
Ref.: 070407

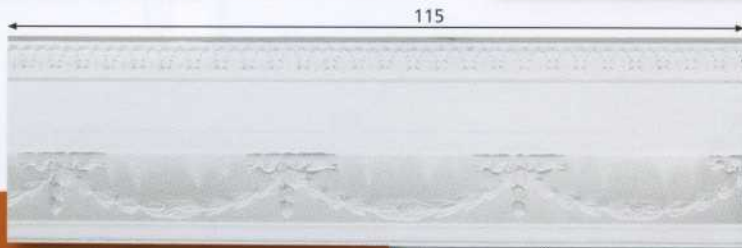

Cornice No. 6 ▶
Ref.: 020406



Cornice No. 8 ▶
Ref.: 080408



Cornice No. 10 ▶
Ref.: 080410



Cornice No. 11 ▶
Ref.: 080411



Cornice No. 12 ▶
Ref.: 070412

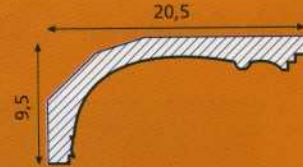
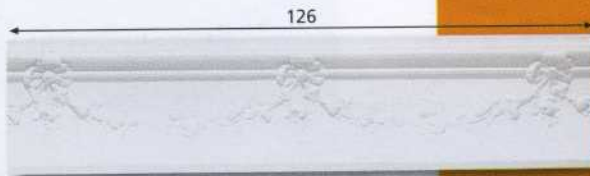

Cornice No. 13 ▶
Ref.: 080413

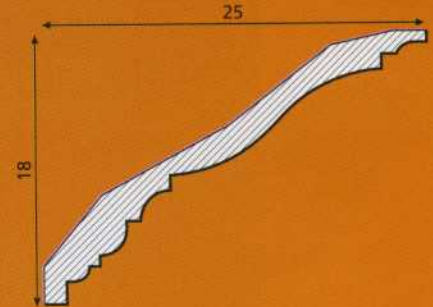

Cornice No. 14 ▶
Ref.: 080414



Cornice No. 15 ▶
Ref.: 080415

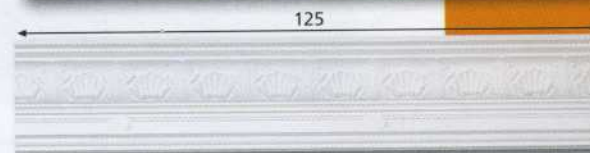

◀ **Cornice No. 16**
Ref.: 070416

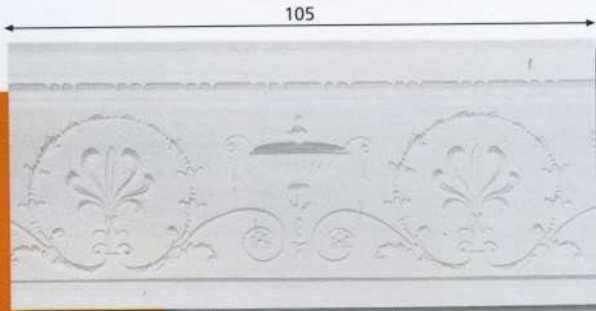

◀ **Cornice No. 17**
Ref.: 080417



◀ **Cornice No. 18**
Ref.: 070418

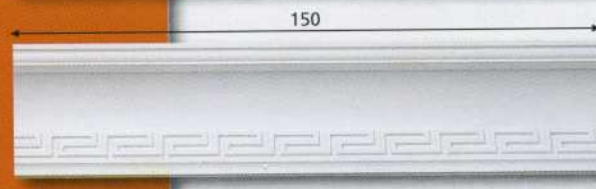
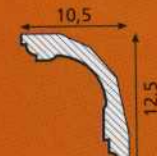

◀ **Cornice No. 20**
Ref.: 070420

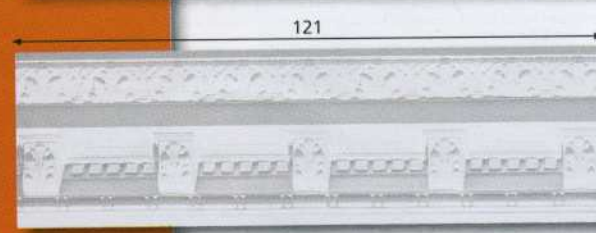
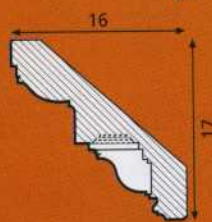

Decorative Cornices



◀ Cornice No. 21
Ref.: 070421



◀ Cornice No. 22
Ref.: 070422



◀ Cornice No. 23
Ref.: 070423



◀ Cornice No. 24
Ref.: 070424



◀ Cornice No. 25
Ref.: 070425



◀ Cornice No. 19
Ref.: 070419



◀ Cornice No. 29
Ref.: 070429

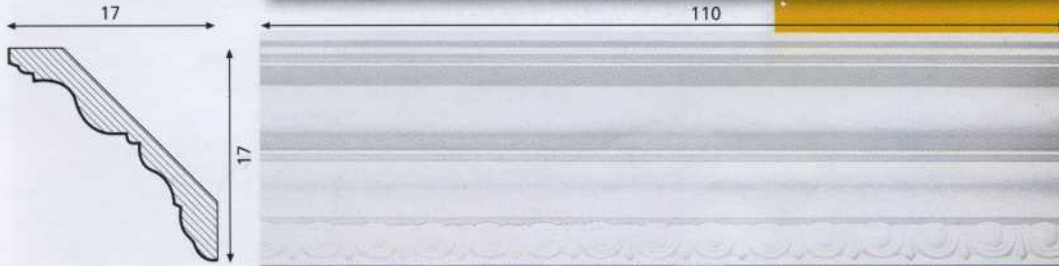

◀ Cornice No. 30
Ref.: 070430

67r

①



▲ Cornice No. 1
Ref.: 020401

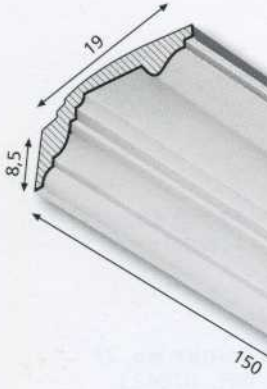

▲ Cornice No. 2
Ref.: 020402

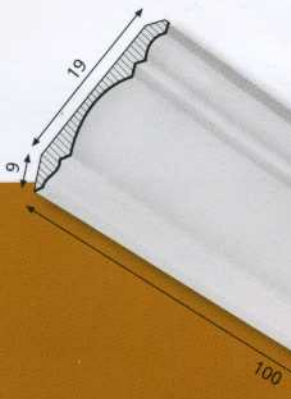

▲ Cornice No. 3
Ref.: 020403

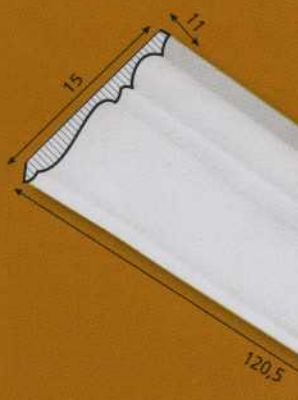

▲ Cornice No. 4
Ref.: 020404

Cornices



▲
Cornice No. 5
Ref.: 020405



▲
Cornice No. 6
Ref.: 020406



▲
Cornice No. 9
Ref.: 020409

Decorative Mouldings



◀ Leaves
Ref.: 020162



◀ Twigs
Ref.: 020161



◀ No. 7
Ref.: 020107



▶ No. 24
Ref.: 020124

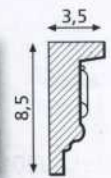

▶ No. 25
Ref.: 020125

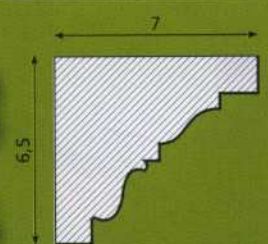

▶ No. 26
Ref.: 020126

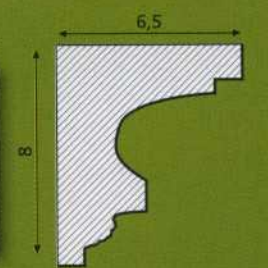

▶ No. 27
Ref.: 020127

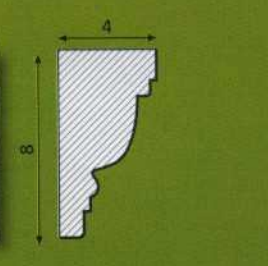



Friezes

Shelf Frieze ▶
Ref.: 07080302

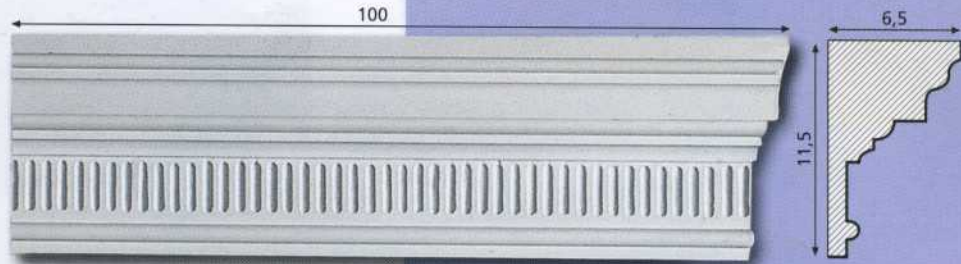

Vegetable Frieze ▶
Ref.: 020163



Frieze No. 1 ▶
Ref.: 070901



Frieze No. 2 ▶
Ref.: 080160
(12 x 5)



Frieze No. 3 ▶
Ref.: 080161
(10 x 3)

Frieze No. 8 ▶
Ref.: 080160/8



Frieze No. 9 ▶
Ref.: 080160/9

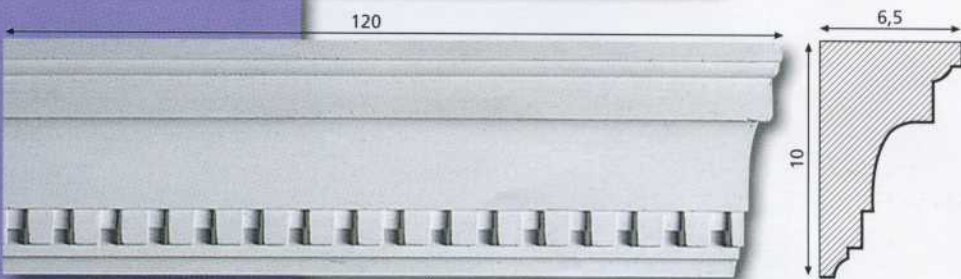

Frieze No. 10 ▶
Ref.: 080160/10

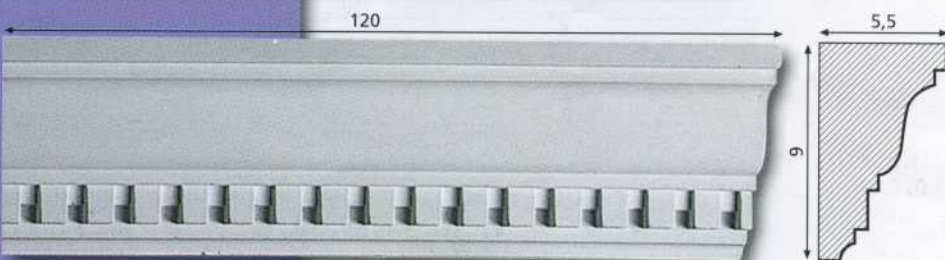

Mouldings



No. 1
Ref.: 020101

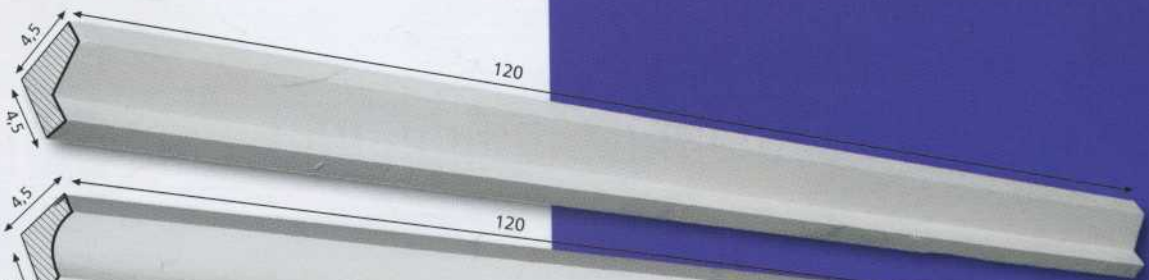

No. 2
Ref.: 020102



No. 3
Ref.: 020103



No. 4
Ref.: 020104

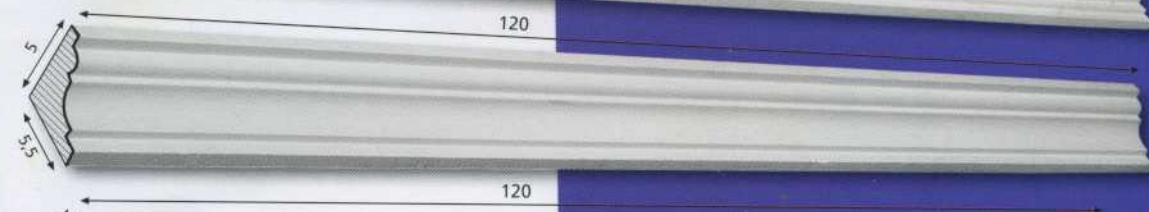

No. 5
Ref.: 020105

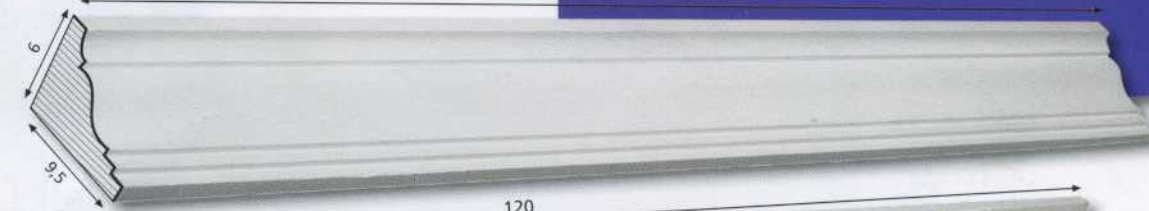

No. 6
Ref.: 020106



No. 8
Ref.: 020108



No. 9
Ref.: 020109



No. 10
Ref.: 020110





◀ No. 11
Ref.: 020111



◀ No. 16
Ref.: 020116

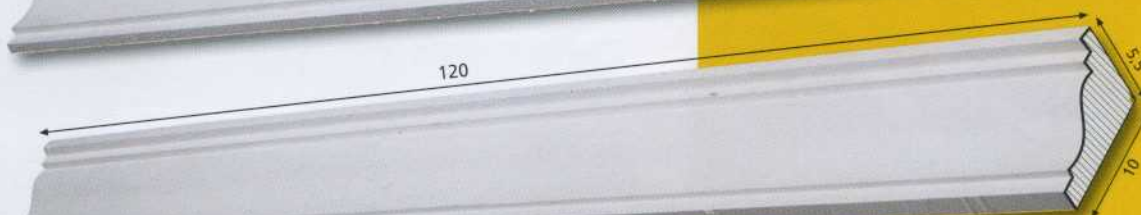

◀ No. 17
Ref.: 020117



◀ No. 18
Ref.: 020118



◀ No. 19
Ref.: 020119



◀ No. 20
Ref.: 020120



◀ No. 21
Ref.: 020121



◀ No. 22
Ref.: 020122

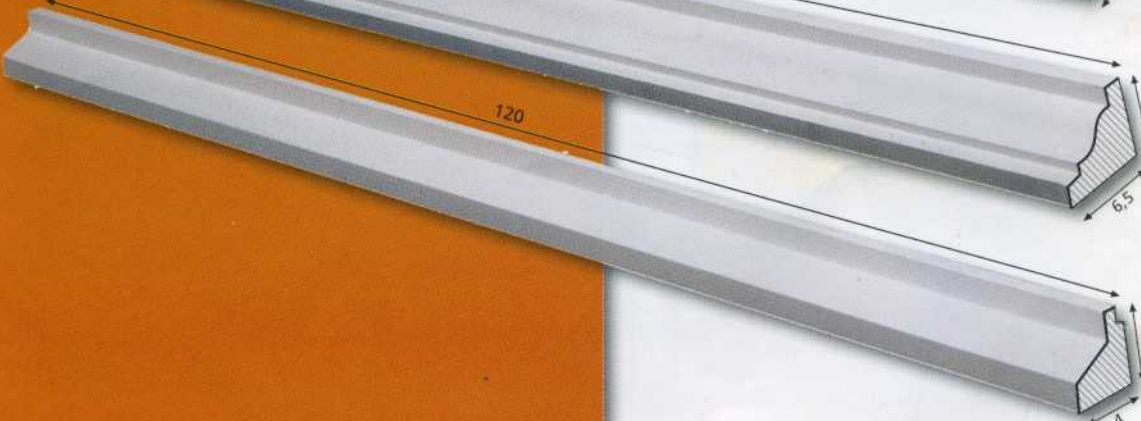

◀ No. 23
Ref.: 020123

281

Wall & Ceiling Mouldings and Complements



▲ Wall & Ceiling Moulding No. 0
Ref.: 070200



▲ Wall & Ceiling Round Moulding No. 1

Ref.:08070651/25
Ref.:070651/30
Ref.:08070651/36
Ref.:070651/51



Ref.:08070652/35
Ref.:08070652/51



Ref.:08070653/23
Ref.:08070653/31
Ref.:08070653/40

▲ Wall & Ceiling Round Moulding No. 3



▲ Corner No. 5
Ref.: 070605



▼ Corner No. 4
Ref.: 070604

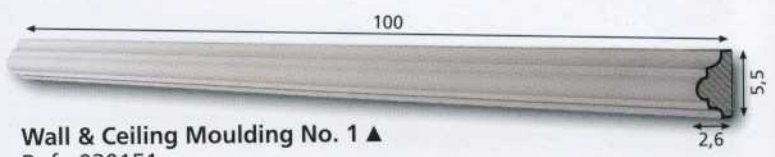

▲ Wall & Ceiling Moulding No. 1
Ref.: 020151

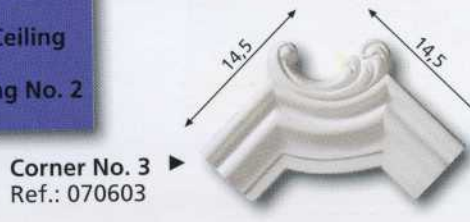

▶ Corner No. 3
Ref.: 070603



▲ Right and Left Corner No. 2
Ref.: 070602



▲ Corner No. 1
Ref.: 070601



▲ Wall & Ceiling Moulding No. 2
Ref.: 020152

▼ Corner No. 9
Ref.: 08070609

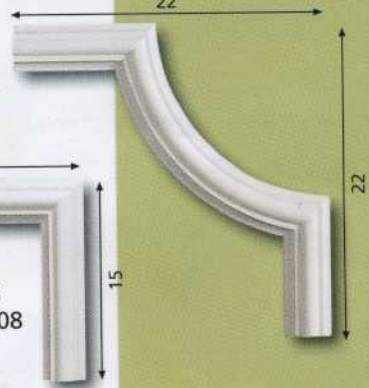

▲ Corner No. 8
Ref.: 08070608



▼ Wall & Ceiling Moulding No. 3
Ref.: 080150/3

▼ Corner No. 6
Ref.: 08070606





Wall & Ceiling Moulding No. 4
Ref.: 080150/4

Corner No. 10
Ref.: 08070610

Wall & Ceiling Moulding No. 6
Ref.: 070206

Corner No. 12
Ref.: 070612

Wall & Ceiling Moulding No. 7
Ref.: 070207

Wall & Ceiling Moulding No. 9
Ref.: 070209

Corner No. 14
Ref.: 070614

Corner No. 11
Ref.: 070611

Wall & Ceiling Moulding No. 8
Ref.: 070208

Wall & Ceiling Moulding No. 10
Ref.: 070210

Wall & Ceiling Moulding No. 11
Ref.: 080150/11

Wall & Ceiling Moulding No. 12
Ref.: 080150/12



Perimetral Fittings



Smooth Strip
Ref.: 020211

Perimetral Shadow 3x5
Ref.: 020201



Perimetral Shadow 4x4x10
Ref.: 020203

Perimetral Shadow 4x4x4
Ref.: 020202



Perimetral Shadow 4x4x30
Ref.: 020204



Perimetral Tray
Ref.: 030120
Ref.: 030130
Ref.: 030140

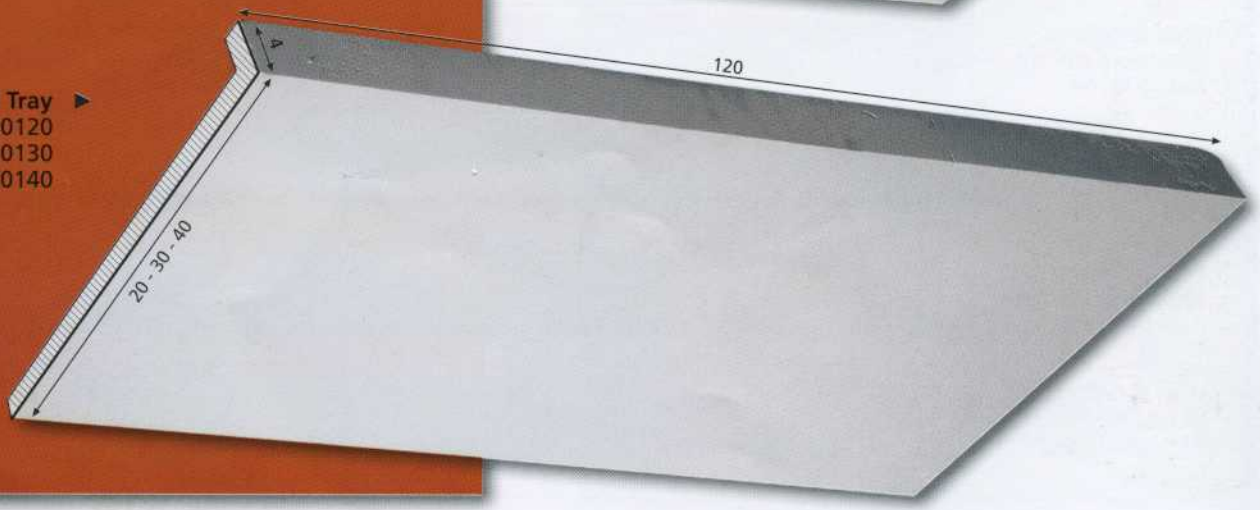

Curtain Covering No. 0 ▶
Ref.: 020300

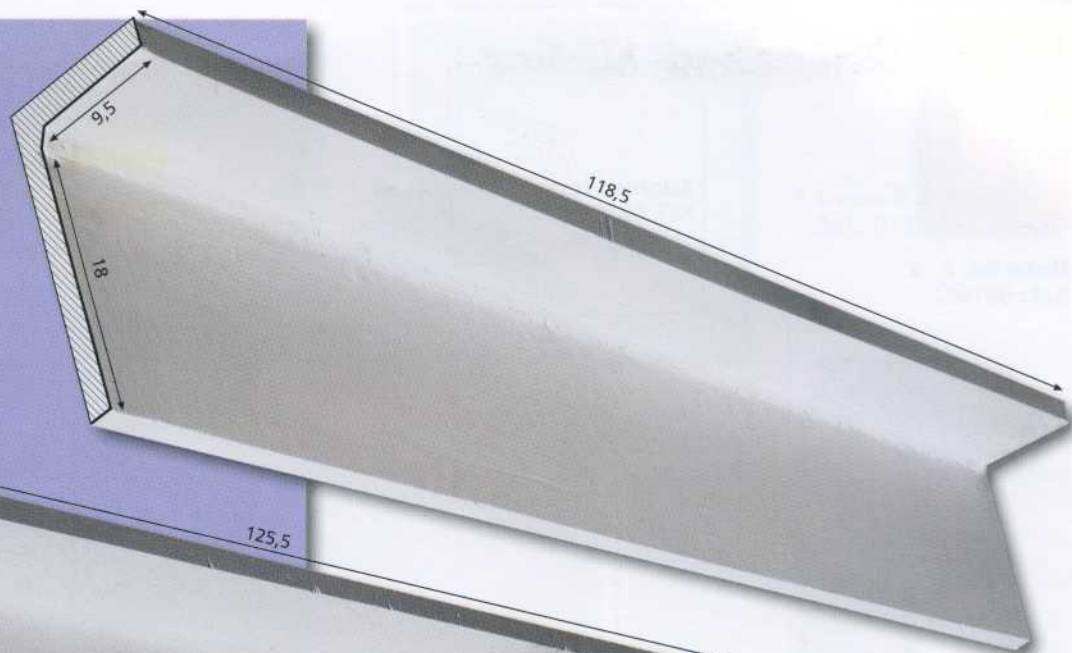

◀ Curtain Covering No. 1
Ref.: 020301



Curtain Covering No. 2 ▶
Ref.: 020302



◀ Rail Curtain Covering
Ref.: 040135
Ref.: 040140





Domes and Niches

Niche No. 2 ▼
Ref.: 081602



Adorned Niche ▼
Ref.:081603

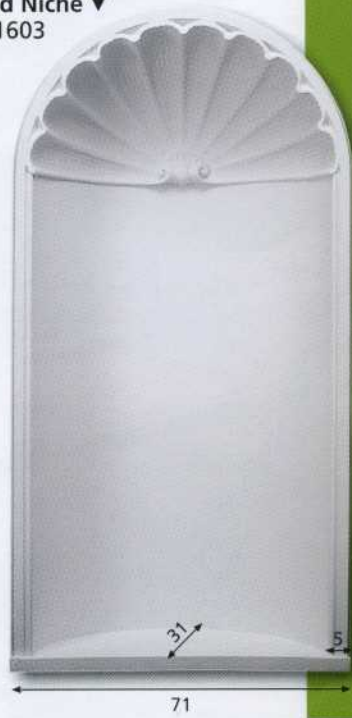

Niche No. 1 ▼
Ref.: 081601

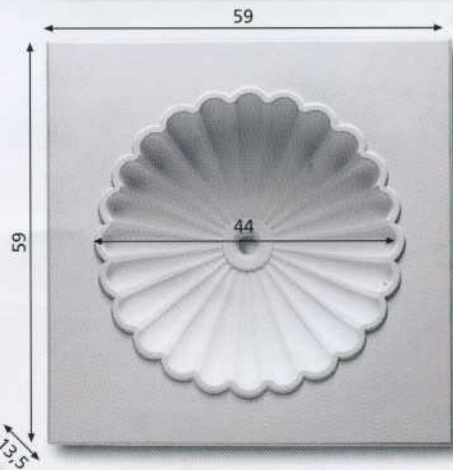

◀ Grooved Dome
Ref.: 080805

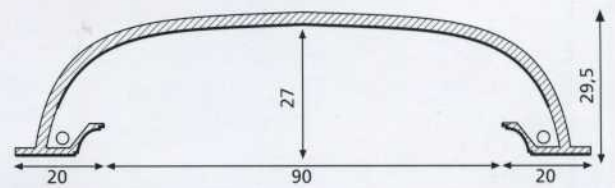

◀ Dome
Ø 120 cm. Indirect Lighting Ref.: 080804

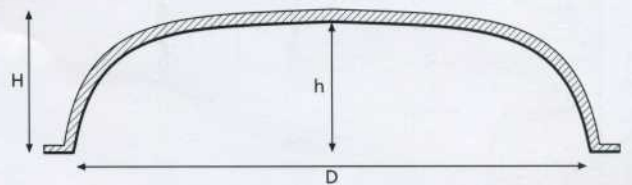

◀ Cúpula

	Ref.:	h	H	D
Ø 45 with round moulding	080801	12	14	49 cm.
Ø 65 "	080802	12	14	69 cm.
Ø 100 "	080803	14	16	104 cm.

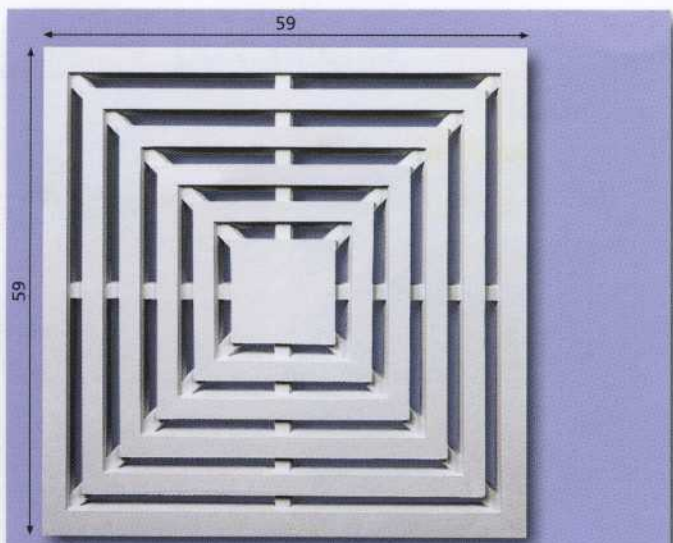

Grille No. 1
Ref.: 0807072

It can be used as a suspended ceiling.

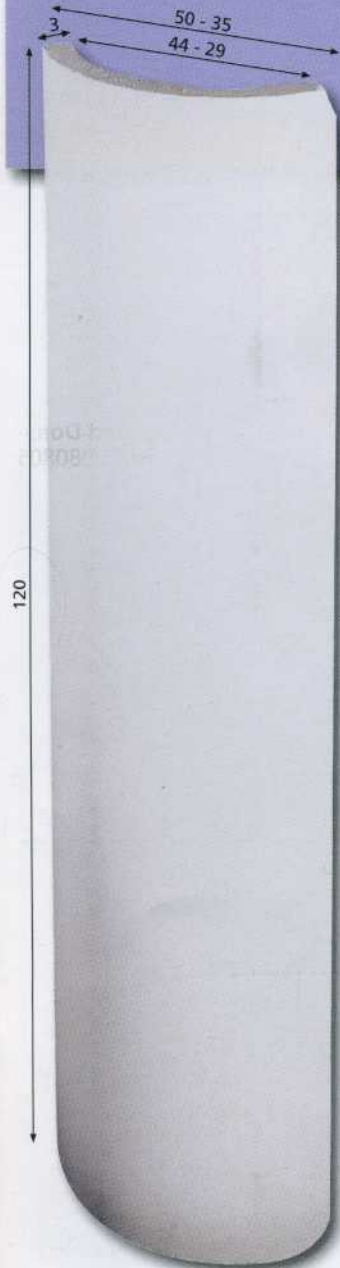

Fireproof Covering Column
35 Ref.: 060101
50 Ref.: 060102

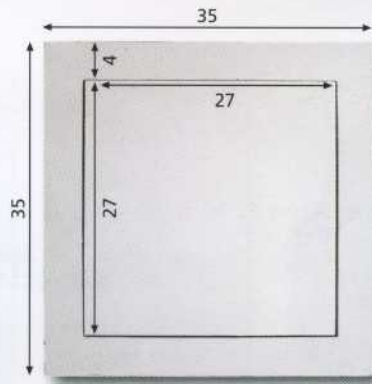
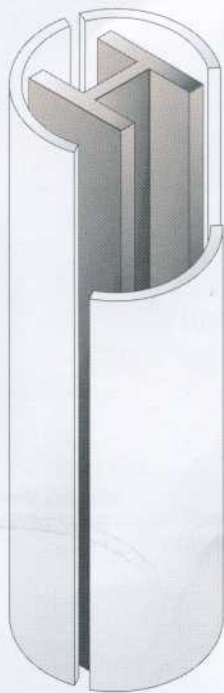

Frame & Lid No. 2
Ref.: 070301

Frame & Lid No. 1
Ref.: 070300

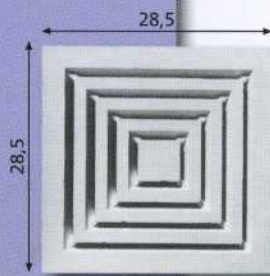
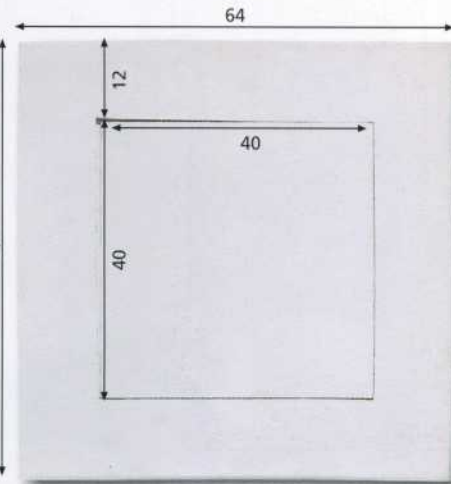

Grille No. 2
Ref.: 070701



Wall & Ceiling Rose No. 2
Ref.: 081702

Wall & Ceiling Rose No. 1
Ref.: 081701

Ø 12



Wall & Ceiling Rose No. 3
Ref.: 081703

Ø 4,4



Wall & Ceiling Rose No. 4
Ref.: 081704

Ø 4,7



Sculptures



▶ **Apolo**
Ref.: 081407

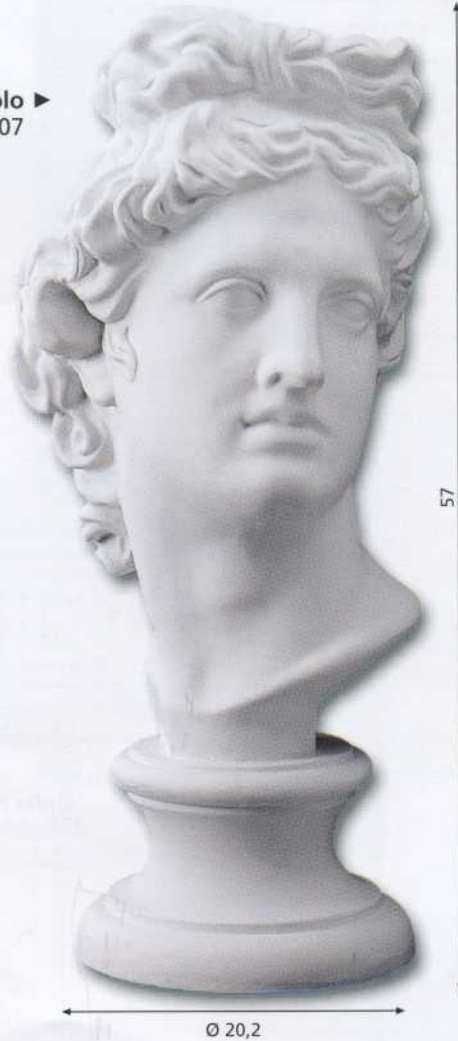

◀ **Afrodita**
Ref.: 081403



◀ **David**
Ref.: 081401

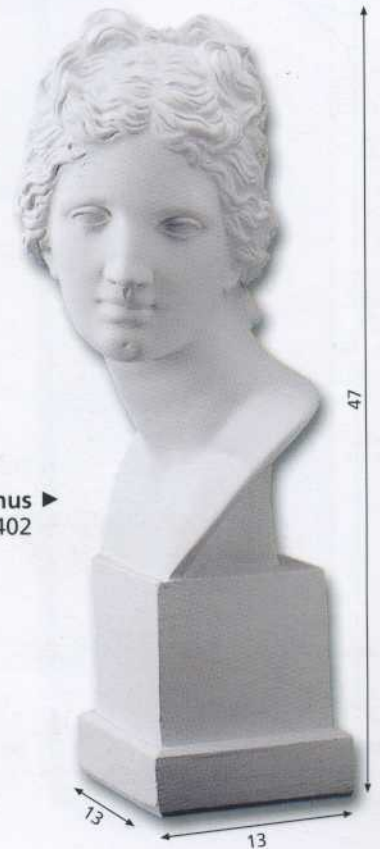

▶ **Medici Venus**
Ref.: 081402

Masculine Torso ▶
Ref.: 081406



▼ Milo Venus
Ref.: 081404



◀ Feminine Torso
Ref.: 081405



Tradicional Ceiling Tiles



Smooth Tile ▶
104 x 60
Ref.: 010101

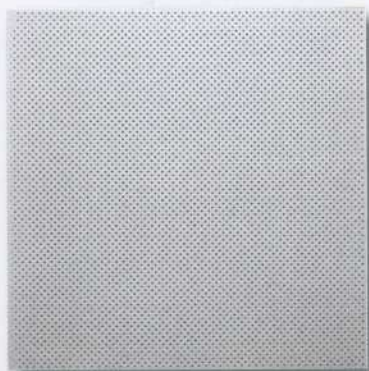

◀ Perforated Tile
60 x 60
Ref.: 010531

◀ Semiperforated tile
60 x 60
Ref.: 010537



Edging Smooth Tile ▶
60 x 60
Ref.: 010501



Club Emblems



▲ F.C. Barcelona
Ref.: 07081454



◀ Valencia C.F.
Ref.: 07081451



▶ R. Madrid
Ref.: 07081457



▶ At. Bilbao
Ref.: 07081452



◀ At. Madrid
Ref.: 07081453

New Tile for Continuous Ceiling



Section

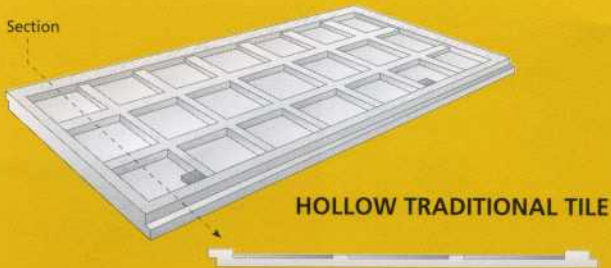

HOLLOW TRADITIONAL TILE

The advantage of this tile is the more thickness at the edge and its nerved structure, which is thicker than the body of the tile but less thick than the edge of it. This make the tile more resistant with less weight.

Section

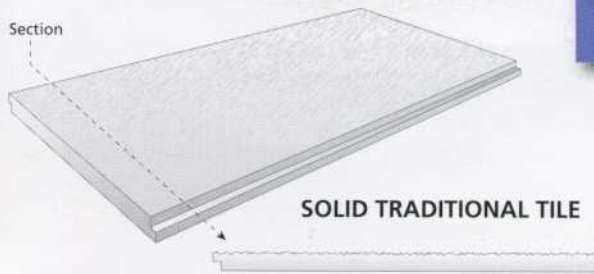

SOLID TRADITIONAL TILE

The advantage of this tile is that it can be easily cut in little strips. Another advantage is that you can paste the esparto in all the surface.

THE NEW TILE: THE ADVANTAGES OF THE HOLLOW AND THE SOLID TILE IN ONE PRODUCT.

Section

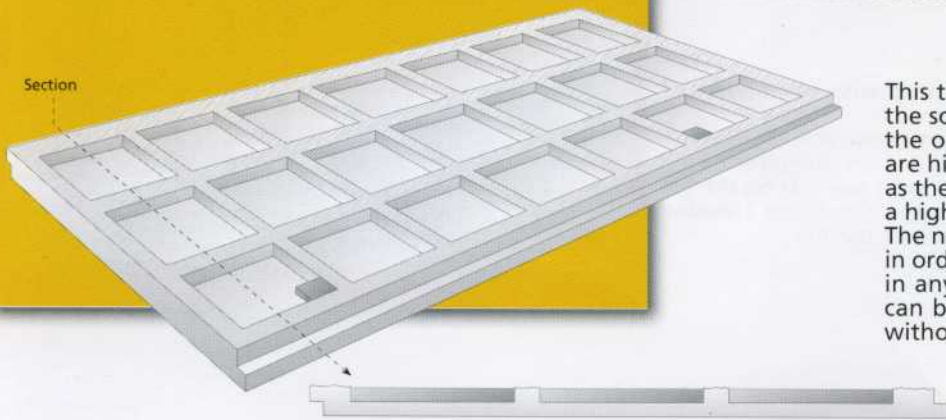

This tile has the advantages of the hollow and the solid tile. Its nerved structure is better than the one of the hollow tile because the nerves are higher than in the hollow tile being as high as the perimeter of the tile. The consequence is a high resistance.

The nerves, instead of being smooth are scraped in order to allow a better pasting of the esparto in any point of the nerves. Moreover, this tile can be cut in thin strips like the solid tile but without the common bulges of the it.

Installation Manual for Continuous Ceiling

The correct installation of the ceiling allows the absorption due to structural movements and avoid fissures and cracks.

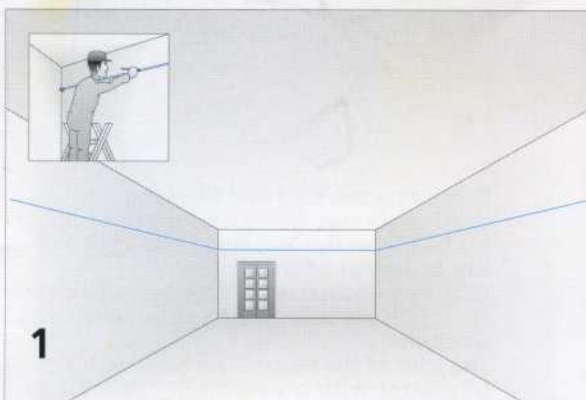

1

1. Before Installing

Before starting to install the tiles, we have to point on the wall and all around the perimeter of the room a line (the level of the finished ceiling).

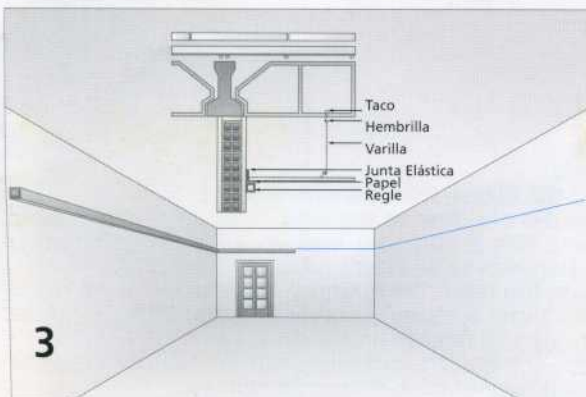

3

3. Separation of the ceiling with an elastic band

We will use an elastic band on which the tile will lay. Once we have installed the ceiling, the fill of the perimeter and the joint of the tiles will be covered with paper band.

2. Separation of the ceiling with prefabricated elements

The tile has not to be touching the wall. We can solve this with mouldings, friezes, cornices, etc. The tile will lay on the moulding, frieze, cornice, etc and separated 5 mm from the wall without fastening it.

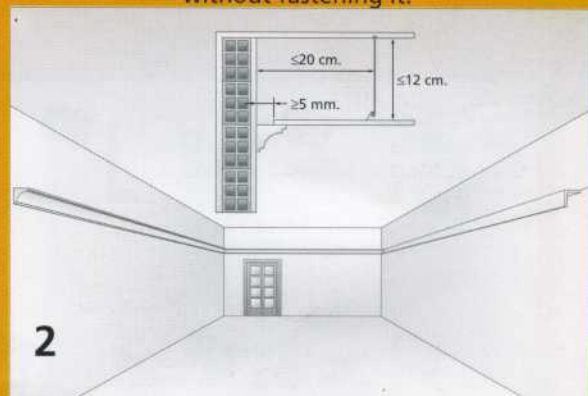

2

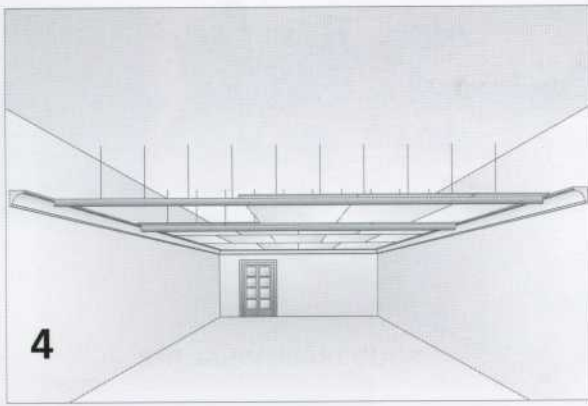

4

4. Installation of the tiles

We have to distribute the braces and rulers and lay out a ceiling tiles plan. It is indispensable to have 2 rulers of advance in order to guarantee the hardening of the patch.



5

5. Kneading the plaster
We will mix plaster and water until they are an unique element. We knead and beat them.

6. Fixing the tiles to the forging with suspenders of galvanised steel

We need 3 fastening per square meter at least. The rod that we use has to have a minimum diameter of 2.7 mm. We will bend the rod 90° with one side on the tile and we will unite them with vegetable fibres kneaded with plaster paste on the hook of the tile.

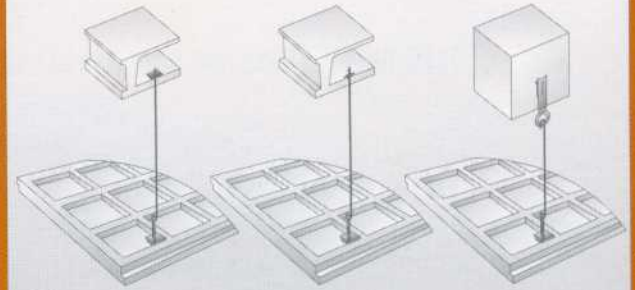

6

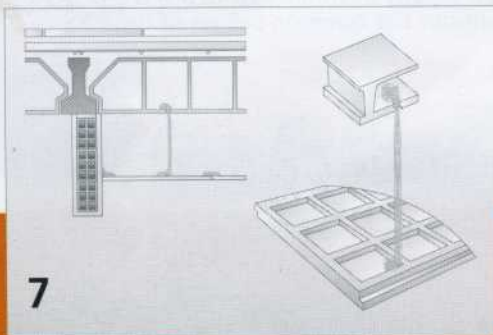

7

7. Fixing the tiles to the forging with suspenders of vegetable fibres

We need 3 fastening per square meter at least. The suspender, made of a mix of vegetable fibres and plaster, has to have a maximum of 2 or 3 cm. This suspender will be hooked to the forging and to the hook of the tile. We can use this kind of suspender if the distance between the forging and the tile is less than 25cm.

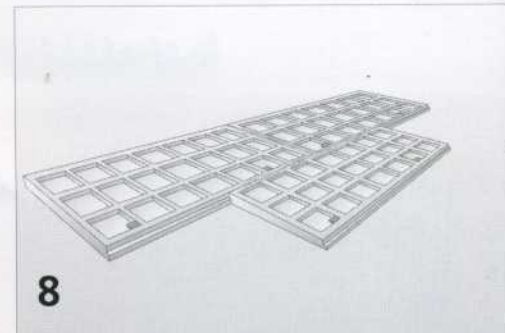

8

8. Joining the tiles and finishing

With vegetable fibres and paste of plaster we will form flat and fine cords covering all the perimeter of the tile.

With large clothes we will made dilation joints for which we will use an elastic putty made of plaster.

The joint of the tiles will be filled with a cloak of plaster with a maximum thickness of 1 mm.

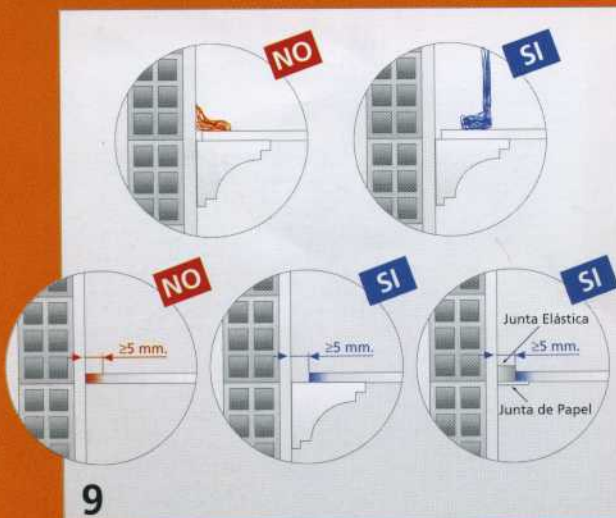

9

9. What to avoid

- Do not fasten the tiles to the wall with esparto.
- Do not install the tile close to the wall. Let a 5mm gap at least. We will achieve this if the tiles lays on a moulding or other prefabricated elements or an elastic band.
- Do not increase too much the quantity of water when we knead the plaster with water because it provokes more retraction of the paste, and consistently, fissures on the tiles.
- Do not remove the bracers and rulers too soon (before the paste gets dry). We will have to wait at least 25 minutes.





Fábrica y Oficinas: Antigua Ctra. Nal. 340, Km. 867

Tel. 96 244 08 84 • Fax: 96 244 05 48

46292 MASSALAVÉS (Valencia - España)

Tel. Internacional: 34 - 96-244 08 84

Fax Internacional: 34 - 96-244 05 48

WEB: www.elalteron.com

Email: elalteron@elalteron.com

Distribuidor

