

CATÁLOGO TARIFA PELLE OCTUBRE 2021



SALGUEDA



LEYENDA · CARACTERÍSTICAS TÉCNICAS



Potencia nominal certificada



Potencia máxima global



Peso aparato



Diámetro tubo salida de humos



Capacidad depósito



Salida aire canalizable



Turbina



Cristal curvo

COLECCIÓN PELLET

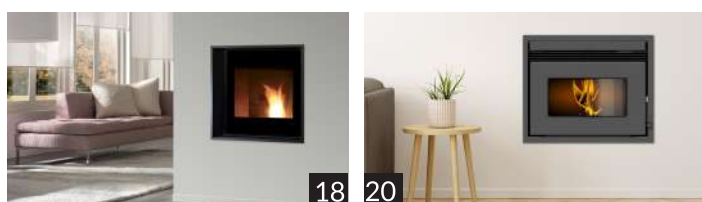

ESTUFAS DE PASILLO

Daglan 4

ESTUFAS

Talo 6
 Nodo 8
 Nola 10
 Adrano 12
 Landa 14
 Zurich 16

INSERTS

MB 18
 Atomo Class 20

SUMARIO
 TÉCNICO 22

DAGLAN

REF. 724104180



COLORES DISPONIBLES



DIMENSIONES

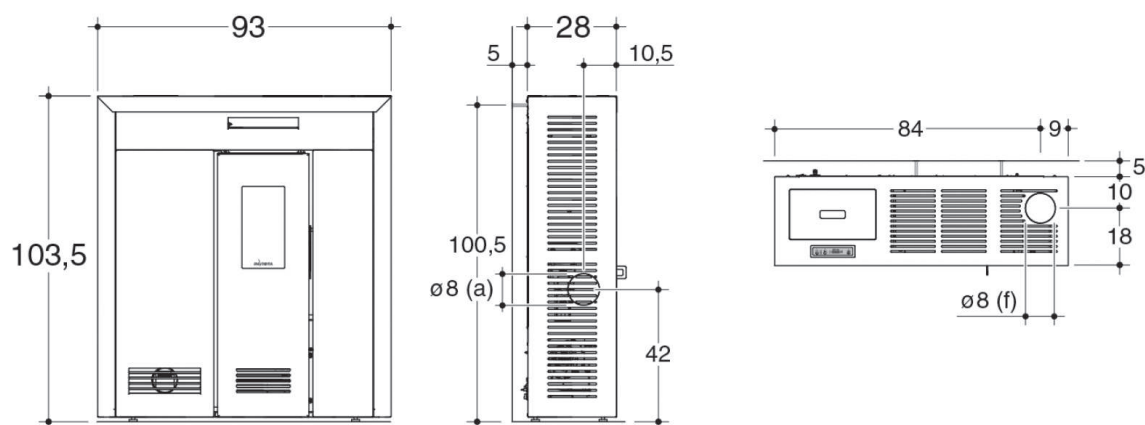



TALO

REF. P641414



COLORES DISPONIBLES



Negro



Rojo



Gris
Metalizado

DIMENSIONES

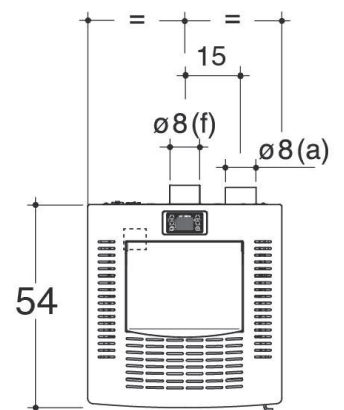
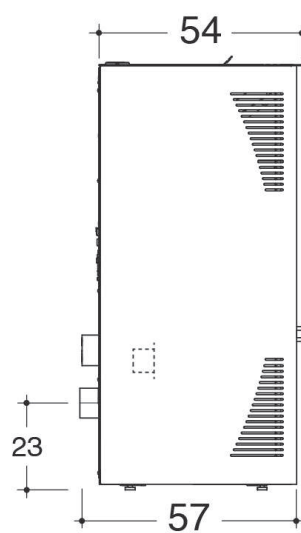
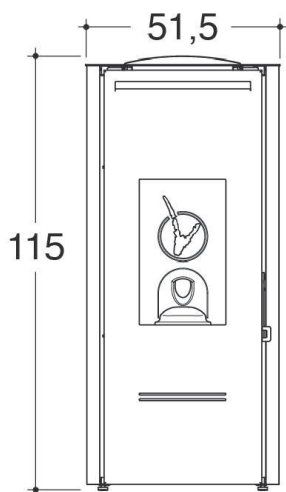





NODO

REF. 724103720



ECO DESIGN
2022

COLORES DISPONIBLES



Rojo



Negro

DIMENSIONES

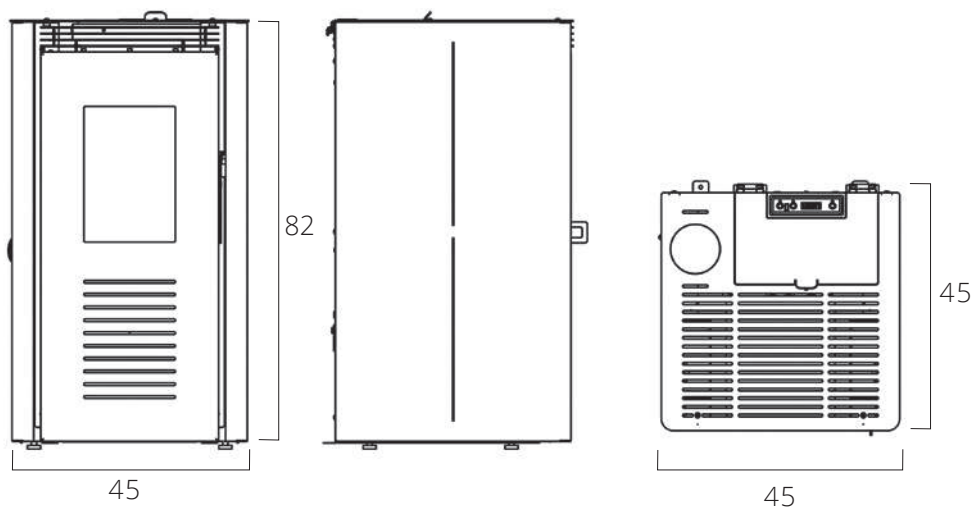

NOLA

REF. 6418



ECO DESIGN
2022

COLORES DISPONIBLES



Rojo Burdeos



Negro



Gris
Metalizado

DIMENSIONES

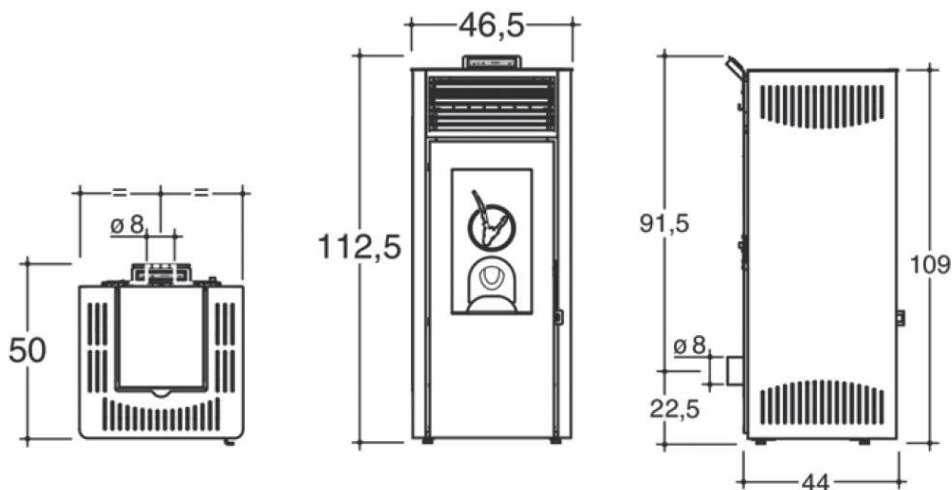





ADRANO

REF. 6409



ECO DESIGN
2022

COLORES DISPONIBLES



Gris
Metalizado



Antracita



Burdeos



DIMENSIONES

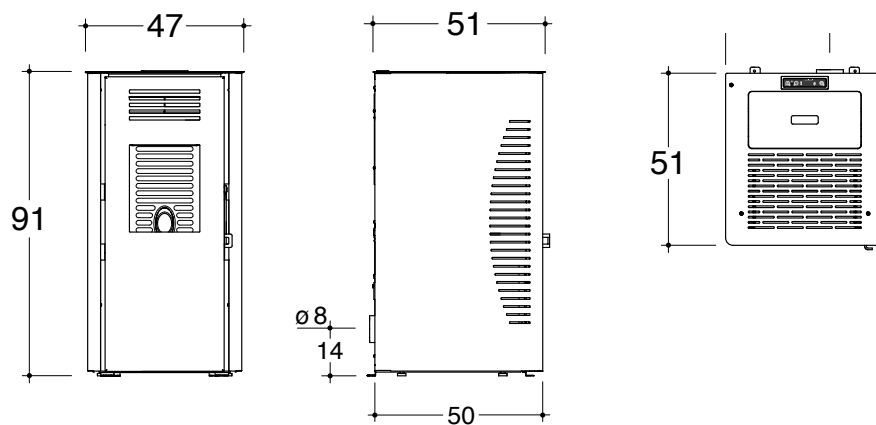

LANDA

REF. 6419



ECO DESIGN
2022

COLORES DISPONIBLES



Rojo Burdeos



Negro



Gris Metalizado

DIMENSIONES

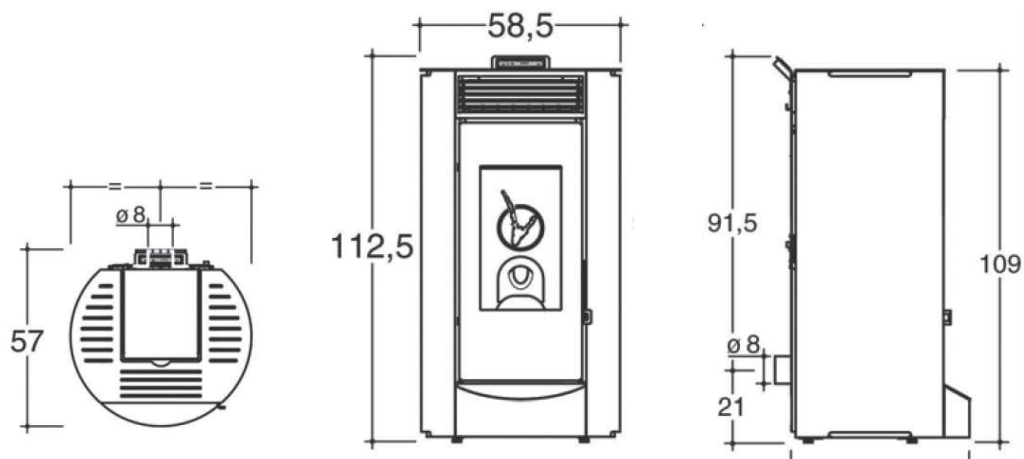





ZURICH

REF. ZURICH12 · ZURICH12 PLUS

ZURICH 12



certificada
4,1- 12



global
12,5 kw



kg
20 kg



kg
134 kg



80 mm



EN OPCIÓN



ZURICH 12 PLUS

Incluye cestillo autolimpiante

COLORES DISPONIBLES



Rojo Burdeos



Negro



Blanco

DIMENSIONES

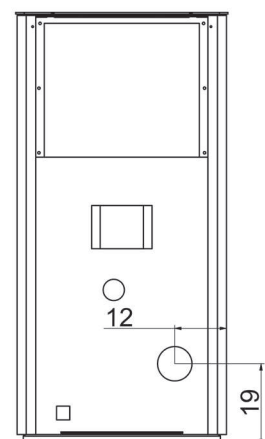
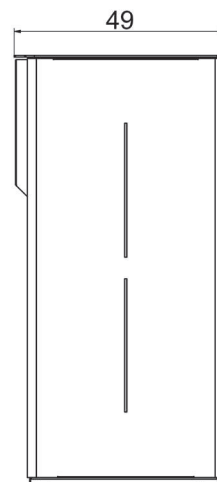
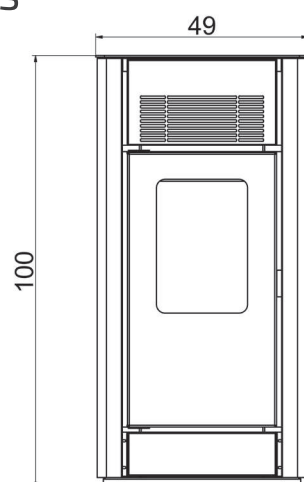

MB

REF. MBP15



Panel de control
Doble salida de aire caliente con rejillas ajustables

50 kg de capacidad de combustible
Distribuidor de llama-catalizador en cerámica refractaria
Circuito de humo
Tornillo sinfín automático que alimenta el combustible según ajuste de funcionamiento
Ventilador de flujo de aire de 480 m³/h.

Extractor de humos
Aire de combustión
Salida de humos de 100 mm
Cajón de cenizas
Patas ajustables

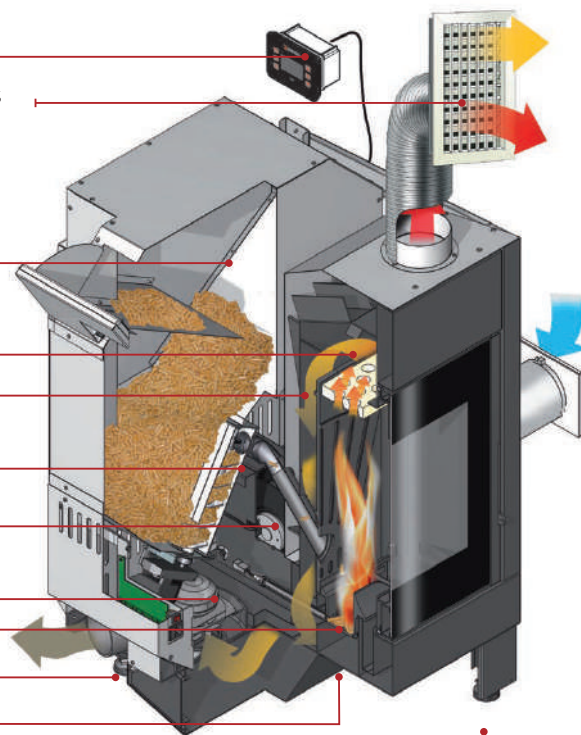

DIMENSIONES

Tolva a la izquierda

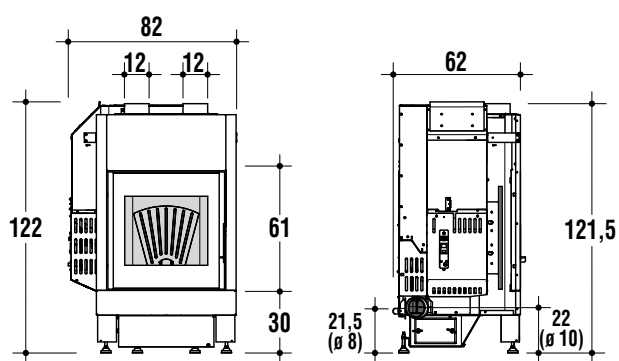

DIMENSIONES

Tolva a la derecha

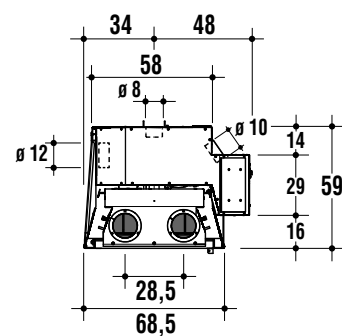
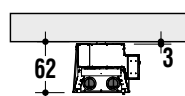
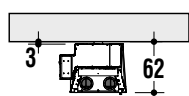
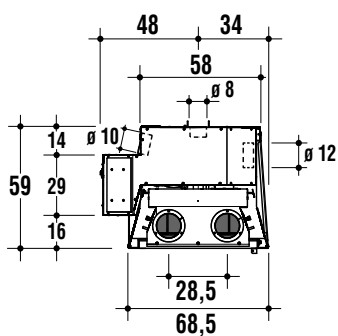
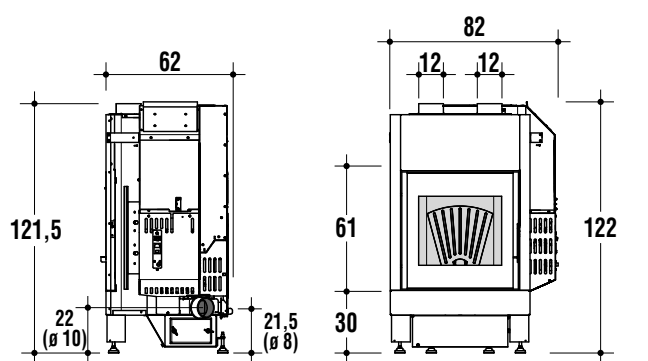





ATOMO CLASS

REF ATC11







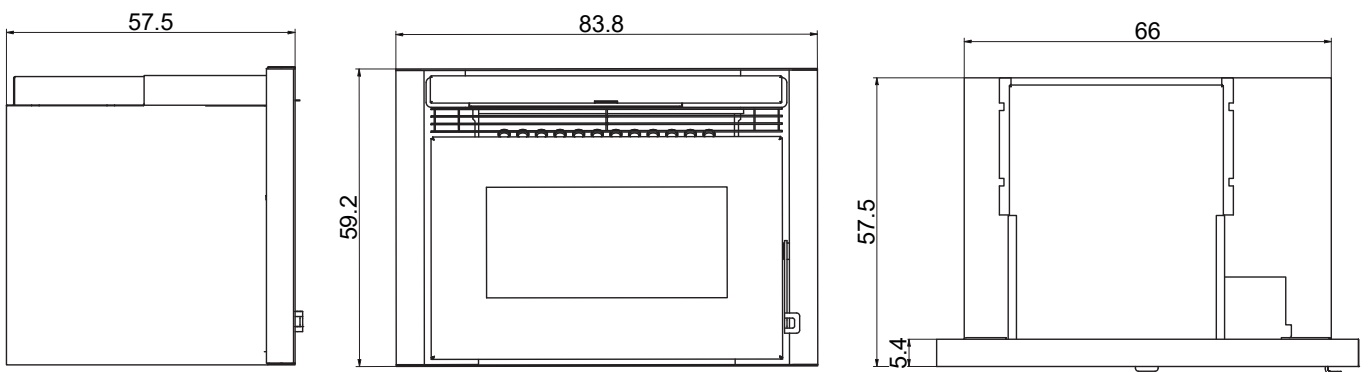











DIMENSIONES



SUMARIO TÉCNICO

Colección Pellet

	PVP	Potencia global	Capacidad depósito	Peso	Diámetro salida de humos	Salida canalizable	Ancho	Alto	Fondo	Colores
 DAGLAN 724104180	1450 €	9,3 kw	15 kg	103 kg	80 mm	1	930	1035	280	
 TALO P641414	1530 €	11 kw	25 kg	98 kg	80 mm	1	515	1150	540	
 NODO 724103720	825 €	5 kw	8 kg	58 kg	80 mm	-	450	820	450	
 ADRANO 6409	895 €	8,2 kw	15 kg	83 kg	80 mm	-	470	950	560	
 NOLA 6418	1285 €	10 kw	16,5kg	108 kg	80 mm	-	465	1120	500	
 LANDA 724104170	1300 €	10,9 kw	16,5kg	108 kg	80 mm	-	588	1125	570	
 ZURICH ZURICH12 ZURICH12 PLUS	1480 €	12,5 kw 12,5 kw	20 kg 20 kg	134 kg 134 kg	80 mm 80 mm	-	490 490	1000 1000	490 490	
 MB MBP15	4250 €	17,5 kw	50 kg	200 kg	100 mm	2	820	1220	620	
 ATOMO CLASS ATC11	2295 €	11 kw	25 kg	121 kg	80 mm	1	780	640	590	



Industrias Salgueda
Polígono Industrial Els Pintors
Picasso, 10
17.500 Ripoll (Girona)
España

salgueda@salgueda.com
www.salgueda.com

Teléfono 972 70 05 97

Móvil 672 210 366 · 672 210 367
672 210 368 · 663 893 075
667 619 001

Fax 972 70 26 03

