

Ficha tecnica PREMIUM III



PREMIUM III

DESENHO TÉCNICO

	A	B	C	D	E	F	Ø _{chaminé}
Prem III	690	520	477	151	460	640	180

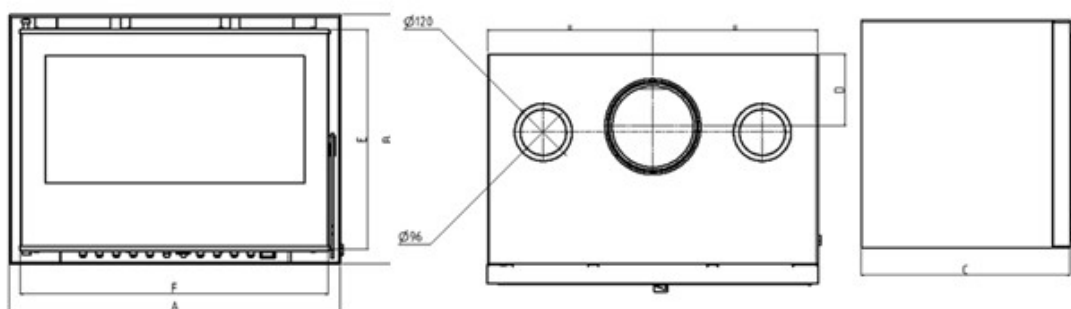

MOLDURAS

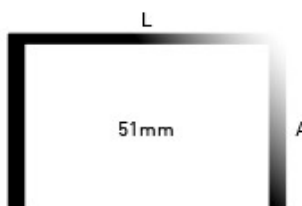

L - 782mm
A - 565mm

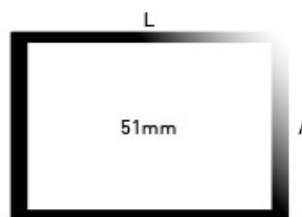

L - 782mm
A - 610mm



CLASSE ENERGÉTICA



EFICIÊNCIA

80%

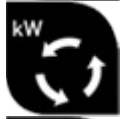

POTÊNCIA

8,3 kW



DIÂMETRO SAÍDA DE FUMOS

180mm



COMBUSTÍVEL CONSUMO/H

2 kg



PESO

115 Kg



VENTILAÇÃO

230 m³/h

Ficha tecnica PREMIUM III



GARANTIA



DIMENSÕES

690(a)x520(b)x477(C)

